

# Revell®

KIT 1442

85144200200

## PLYMOUTH® HEMI® ENGINE

The mighty 426 Plymouth® HEMI® engine was arguably the most feared and legendary power plant to appear in the muscle car era. Available only until 1971 (emissions standards forced it into obsolescence), it possessed an astonishing 425 hp with 490 foot-pounds of torque. Standard on the HEMI® Cuda was a "shaker" fully functional air scoop. Aptly named as it was mounted directly to the engine - poking up through a hole in the hood and thus "shaked" when the engine did. The relatively high cost of the HEMI® engine option (nearly a third of the base price model cost), meant low production numbers. Today the rarity of these cars with the HEMI® engines and collector interest in them has commanded incredible price appreciation - with private sales reportedly occurring at over a million dollars! Your Revell kit comes with rubber belts that connect all moving parts, authentic details, such as fuel lines, hoses and shaker hood scoop. Molded and factory painted in authentic colors with plated parts and tampo printing, and stand.



Plymouth® HEMI® Engine ©DaimlerChrysler Corporation 2007



\* REPEAT SEVERAL TIMES  
\* A REPETER PLUSieurs fois



\* CEMENT TOGETHER  
\* A COLLER



\* DO NOT CEMENT  
\* NE PAS COLLER

If you have any questions or comments, call our hotline at: **(800) 833-3570**  
or, please write to:

Revell-Monogram Consumer Service Department, 725 Landwehr Road, Northbrook, Illinois 60062

Be sure to include the plan number (85144200200), part number, description, your return address and phone number.

Visit our website: [www.revell.com](http://www.revell.com)

REVELL-MONOGRAM, LLC Northbrook, IL Copyright © 2007. All rights reserved.

1

# ENGINE ASSEMBLY



FINE  
THREAD



THICK  
COURSE



THIN  
COURSE



FLAT HEAD  
COURSE

A



ENGINE  
BLOCK

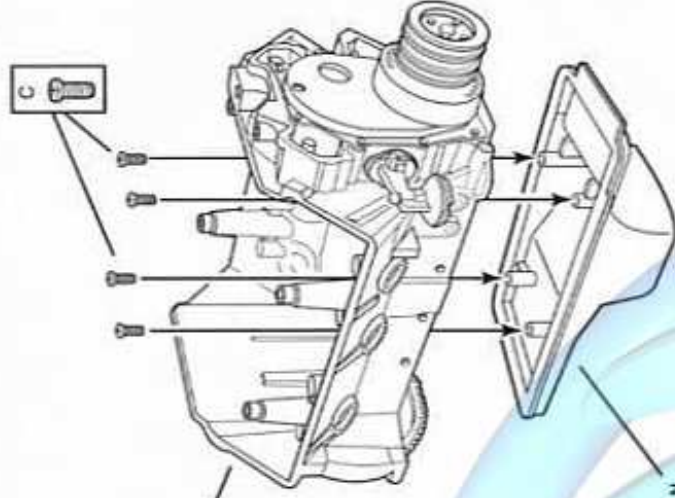

OIL PAN

D

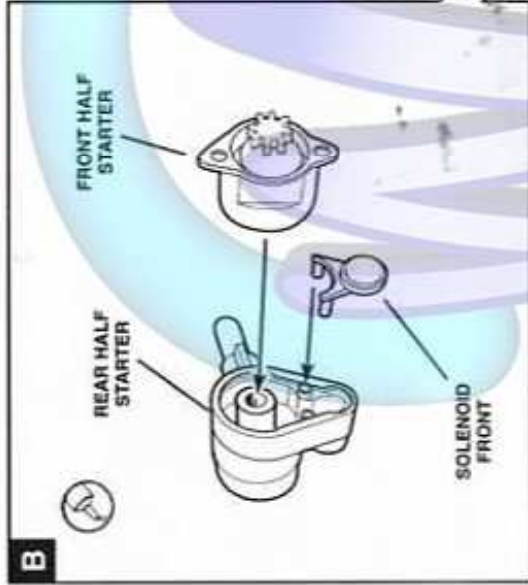

REAR HALF  
STARTER

FRONT HALF  
STARTER

SOLENOID  
FRONT

C

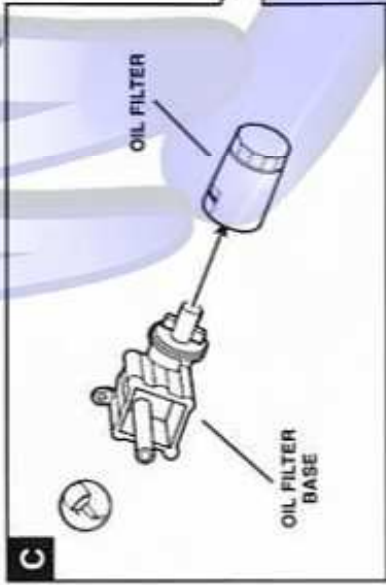

OIL FILTER

OIL FILTER  
BASE

E



DIP STICK



4

# CARBURATOR ASSEMBLY

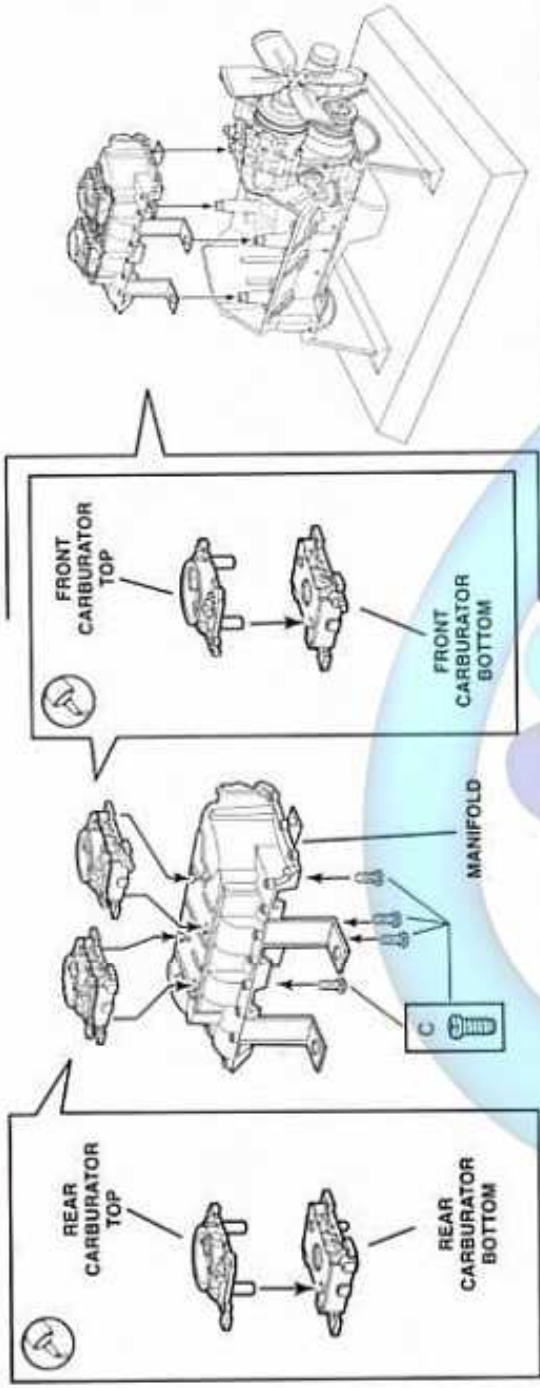

5

# HEADS / EXHAUST ASSEMBLY

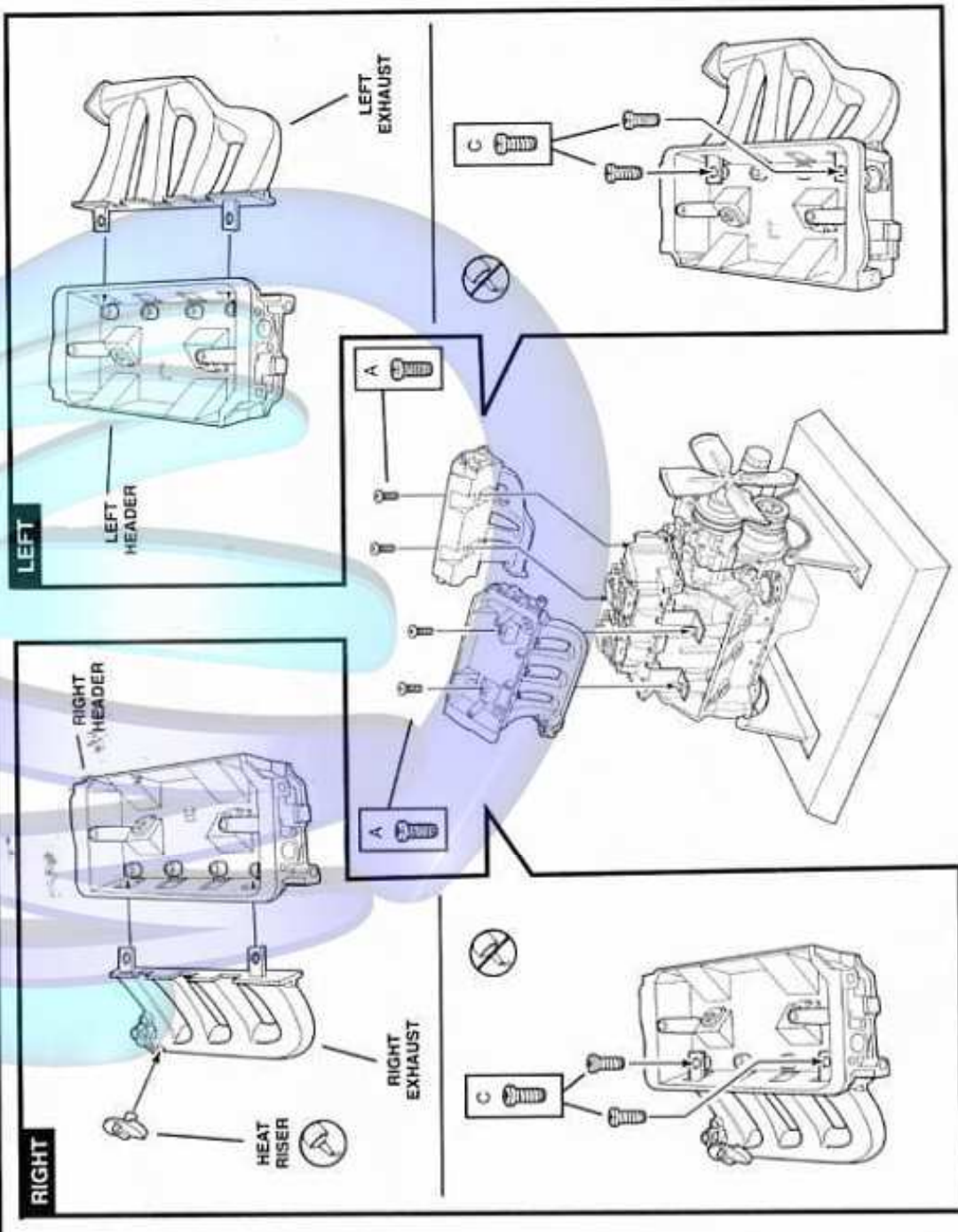

# 6

# DISTRIBUTOR / COIL ASSEMBLY

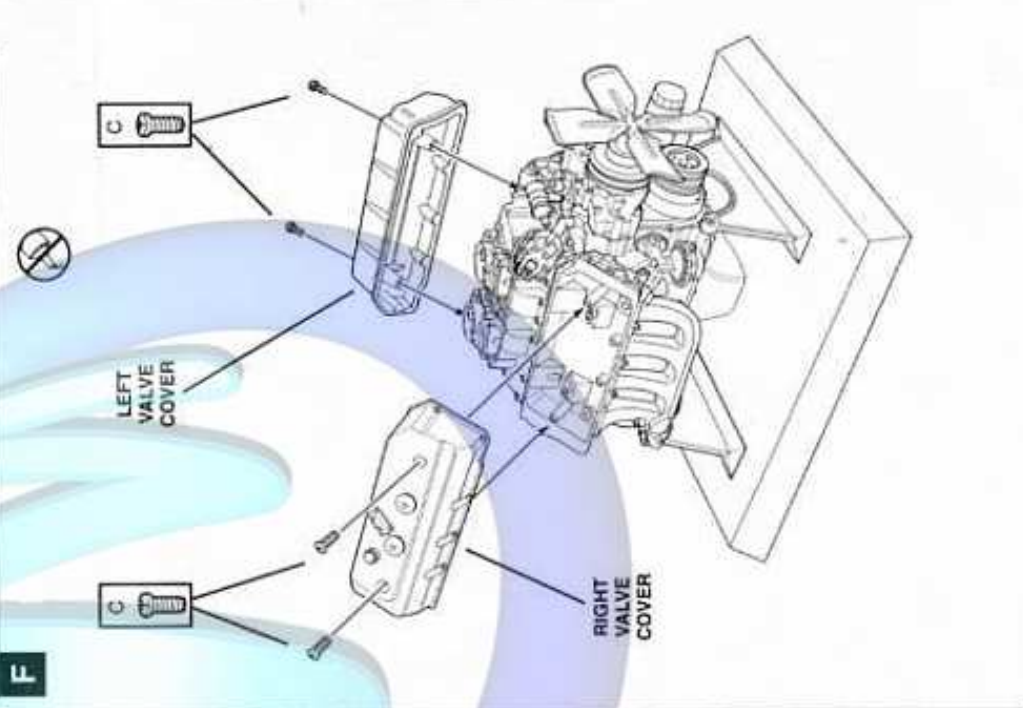
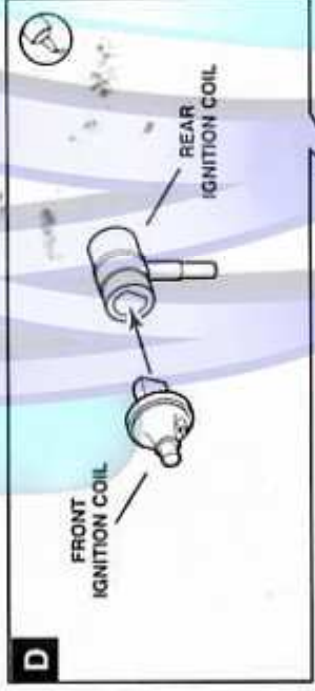
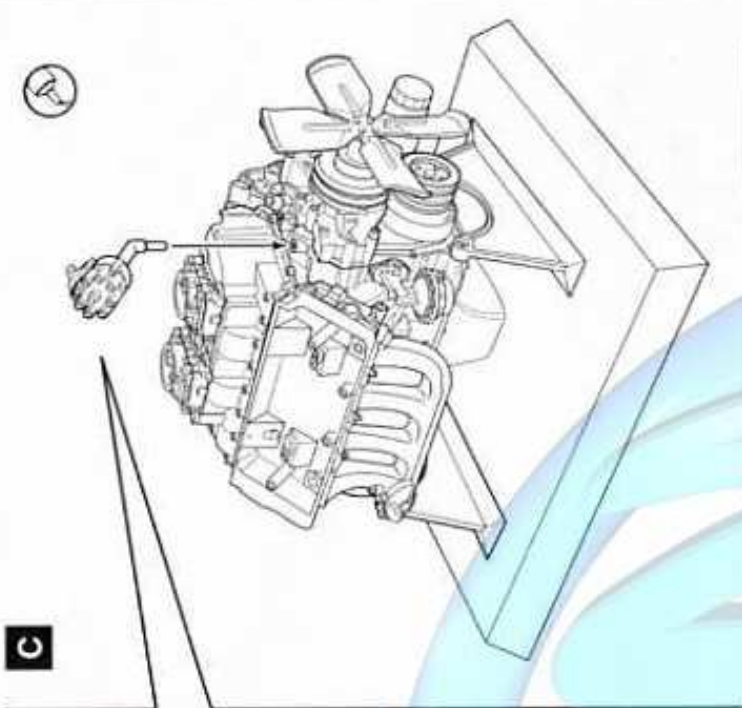
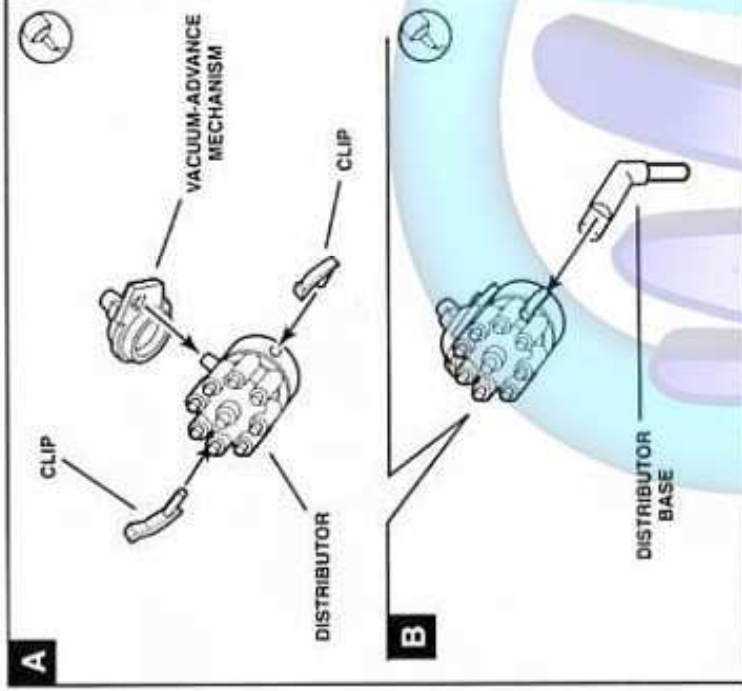



# 7

# GENERATOR / PUMP ASSEMBLY

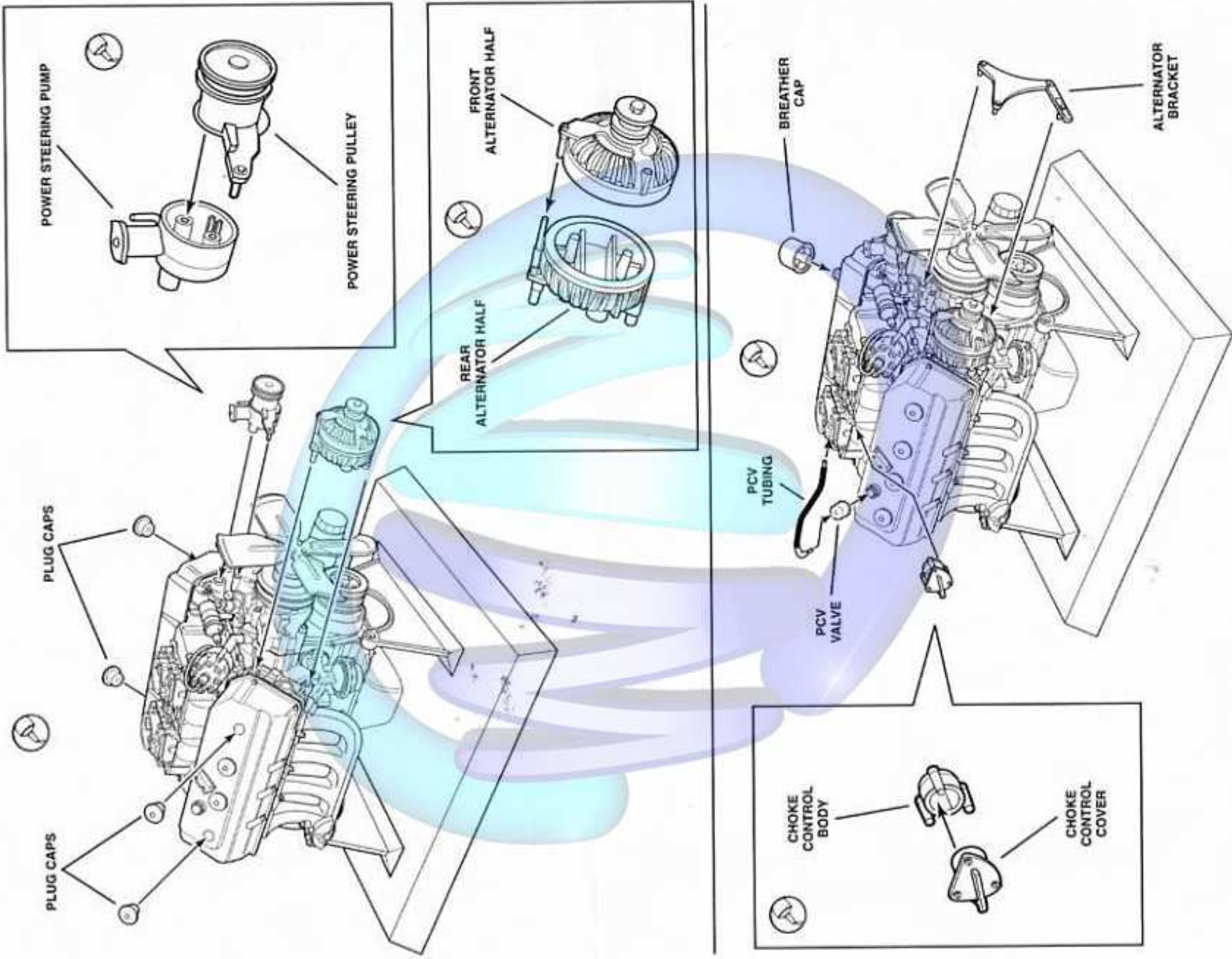

# 8

# TUBING / FUEL LINE ASSEMBLY

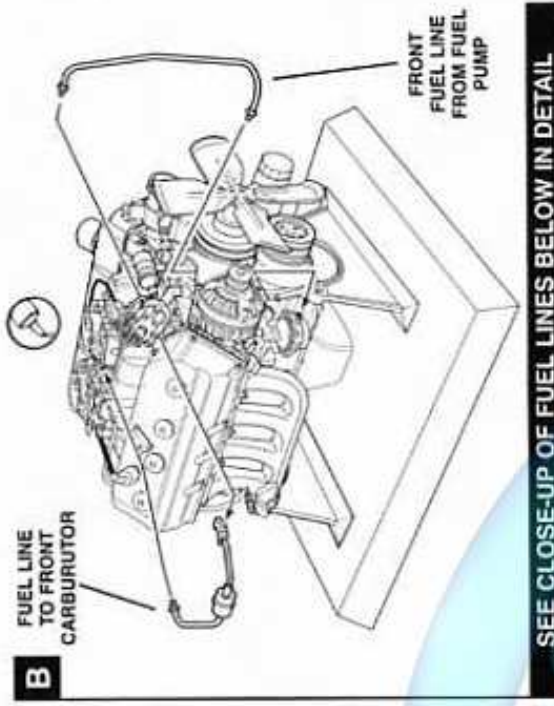
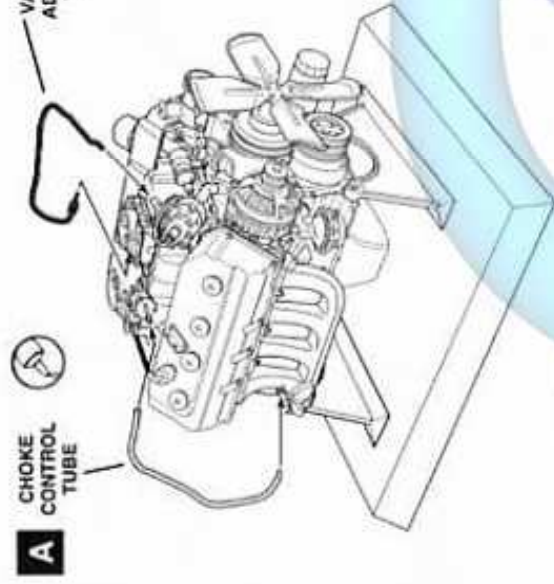

SEE CLOSE-UP OF FUEL LINES BELOW IN DETAIL

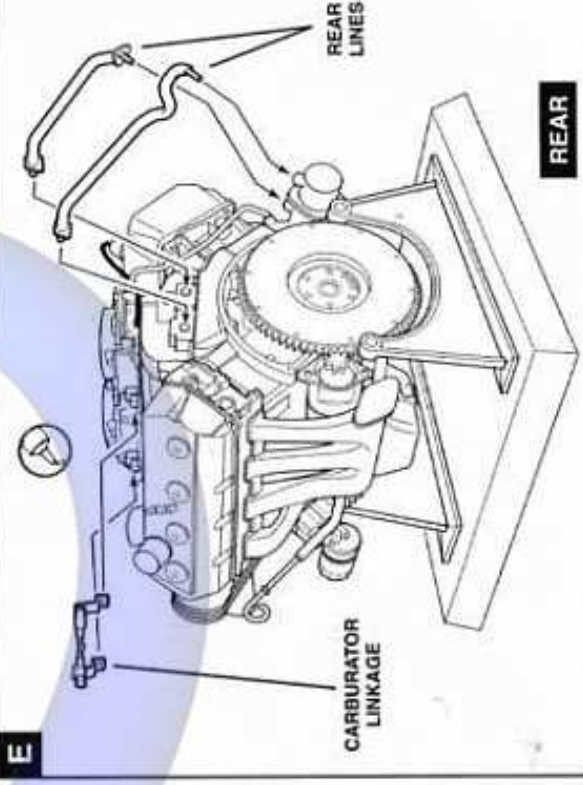
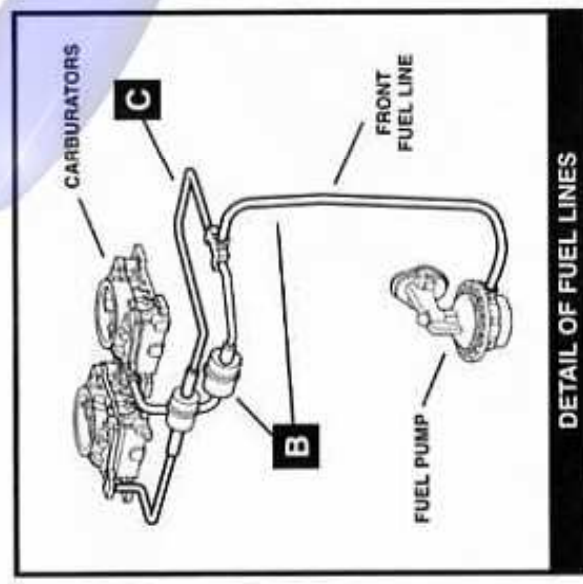
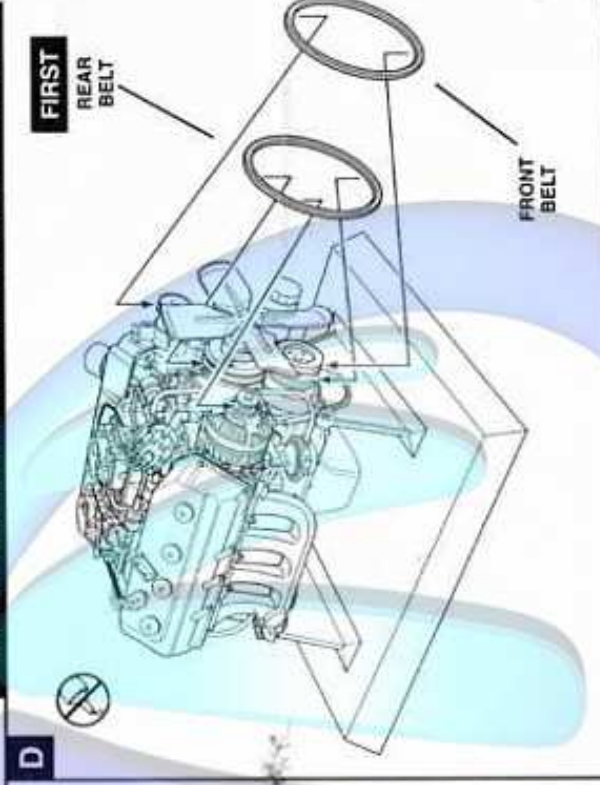

DETAIL OF FUEL LINES



9

# FINAL ASSEMBLY

TOP VIEW SPARK PLUG DIAGRAM

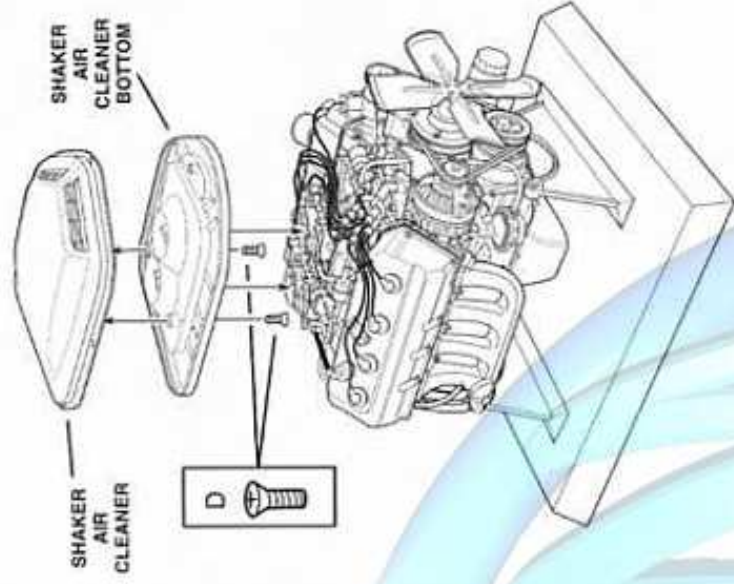
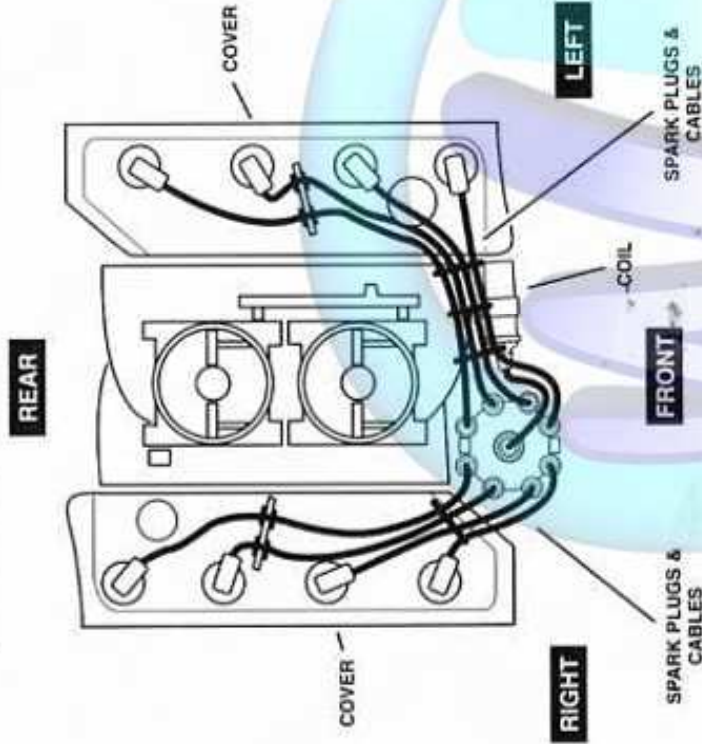

10

# COMPLETED ENGINE

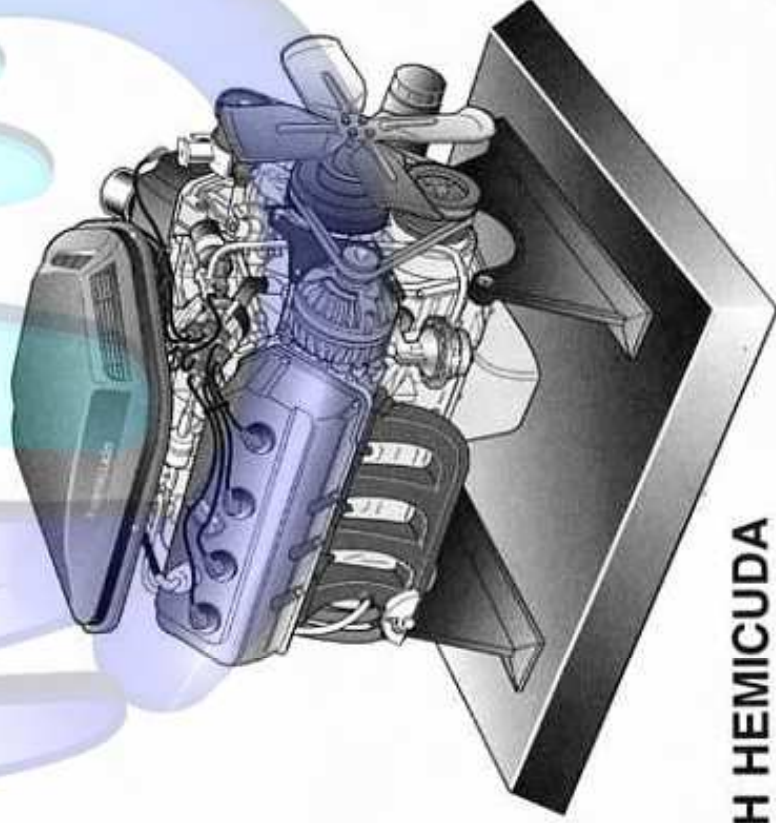

PLYMOUTH HEMICUDA