

U.S.S. CONSTELLATION

REVELL-MONOGRAM, LLC Northbrook, IL. Copyright © 2006. All rights reserved.
 85173100200
 Visit our website: www.revellmonogram.com
 Be sure to include the plan number (85173100200), part number, description, your return address and phone number.
 Revell-Monogram Consumer Service Department, 725 Landwehr Road, Northbrook, Illinois 60062
 or, please write to:
 If you have any questions or comments, call our hotline at: (800) 833-3570



MODEL KIT 1731



The U.S.S. "Constellation" was the second "Kitty Hawk" class attack aircraft carrier to be launched. Built in the New York Naval Shipyard, this modern supercarrier is named in honor of a famed United States frigate built in 1797. This levitation can attain speeds in excess of 35 knots and launch an impressive array of modern jet aircraft. The "Constellation" is manned by more than 4900 men. The ship is 1,072 feet long and flight deck is nearly 249 feet wide at its widest point.

CONSTELLATION

U.S.S.

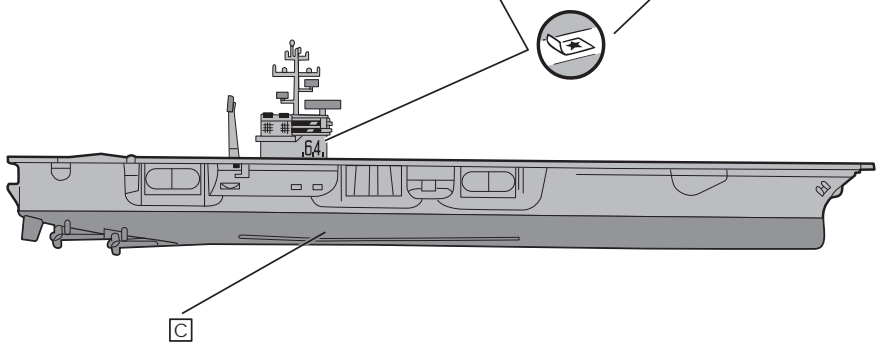
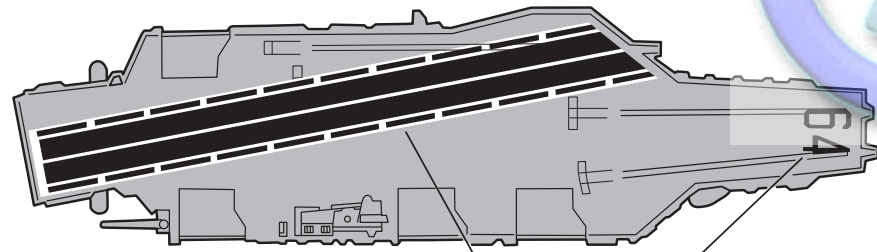

- READ THIS BEFORE YOU BEGIN**
- Study the assembly drawings.
 - Each plastic part is identified by a number.
 - Model may be painted to match photos on box.
 - Allow paint to dry thoroughly before handling parts.

- ALLGEMEINE HINWEISE**
- Die Anordnung der Bauteile ist aus den Zeichnungen der Anleitung ersichtlich.
 - Jedes Plastikteil ist durch eine Nummer gekennzeichnet.
 - Man kann das Modell nach den Fotos auf der Schachtel anstreichen.
 - Bemalte Teile vor der Weiterverwendung gut trocknen lassen.

- LEA ESTO ANTES DE EMPEZAR**
- Estudie los dibujos de ensamble.
 - Cada pieza de plástico se identifica por un número.
 - El modelo puede pintarse de acuerdo con las fotografías de la caja.
 - Permita que se seque la pintura completamente antes de tocar las piezas.

- LEES DIT ALVOREN TE BEGINNEN**
- Bestudeer de bouwtekening.
 - Elk plastic onderdeel is genummerd.

- Men kan model verven zoals aangeduid op de doos.
- Laat de verf van de te verwerken delen steeds goed drogen.

- LISEZ CE QUI SUIT AVANT DE COMMENCER LE MONTAGE**
- Etudiez les schémas d'assemblage.
 - Chaque pièce plastique porte de numéro d'identification.
 - Le modèle peut être peint conformément aux photos sur la boîte.
 - Laissez sécher la peinture complètement, avant de manipuler les pièces.
 - Grattez la peinture sur les surfaces devant être collées.

- LAS DET HAR INNAN DU BORJAR BYGGA**
- Studera monteringskisserna.
 - Alla plastdelar har identifikationsnummer.
 - Modellen kan målas enligt fotona på kantongen.
 - Låt färgen torka ordentligt före limningen.

- DA LEGGERE PRIMA DI INIZIARE**
- Studia le illustrazioni.
 - Ogni pezzo è identificato da un numero.
 - Il modello si può dipingere seguendo le fotografie sulla scatola.
 - Aspetta che la vernice sia completamente asciutta prima di maneggiare le parti.

A	FLAT BLACK	GLANZLOSES SCHWARZ	NEGRO APAGADO	GLANZLOOS ZWART	NOIR TERNE	MATTSVART	NERO OPACO
B	WHITE	WEISS	BLANCO	WIT	BLANC	VIT	BIANCO
C	RED	ROT	ROJO	ROOD	ROUGE	RÖD	ROSSO
D	COPPER	KUPFER	COBRIZO	KOPER	CUIVRE	MÖRKGRÖN	RAME

- THIS KIT MAY BE SNAPPED TOGETHER, BUT PARTS MAY BE CEMENTED IF YOU PREFER.
- DIE TEILE DIESER BAUSÄTZE WERDEN DURCH ZUSAMMENSTECKEN VERBUNDEN, KÖNNEN JEDOCH, FALLS GEWÜNSCHT, VERKLEBT WERDEN.
- ESTE KIT PUEDE SER ENSAMBLADO A PRESION.
- PERO LAS PIEZAS SE PUEDEN UNIR CON PEGAMENTO SI SE PREFERE.
- DEZE KIT KAN NAAR KEUSE MET OF ZONDER LIJM WORDEN GEMONTEERD.
- CETTE MAQUETTE S'ASSEMBLE PAR SIMPLE PRESSION, MAIS VOUS POUVEZ COLLER LES PIECES SI VOUS LE PREFEREZ.
- DENNA BYGGSÄTS KAN SNÄPPAAS IHOP, MEN DELARNA KAN OCKSÅ LIMMAS IHOP OM SÅ FÖREDRAS.
- IL MONTAGGIO DEL CONTENUTO DI QUESTA SCATOLA PUO ESSERE EFFETTUATO CONGIUNGENDO LE PARTI A SCATTO A SCELTA, E' POSSIBILE ANCHE INCOLLARLE.

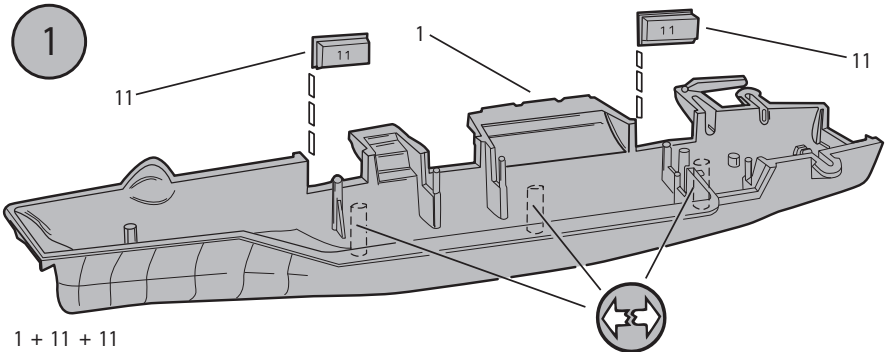
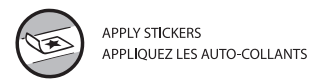
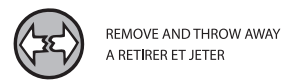

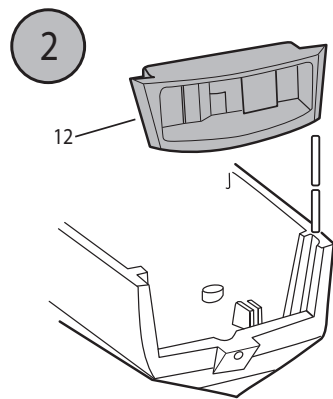

① + 12

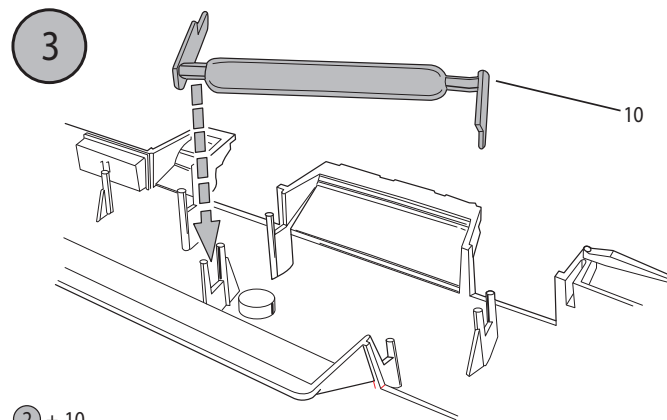

② + 10

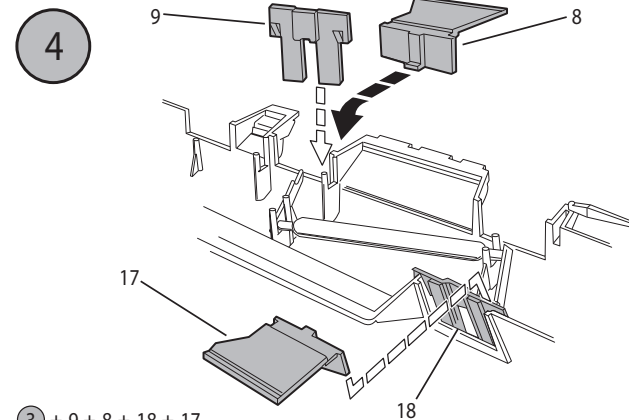

③ + 9 + 8 + 18 + 17

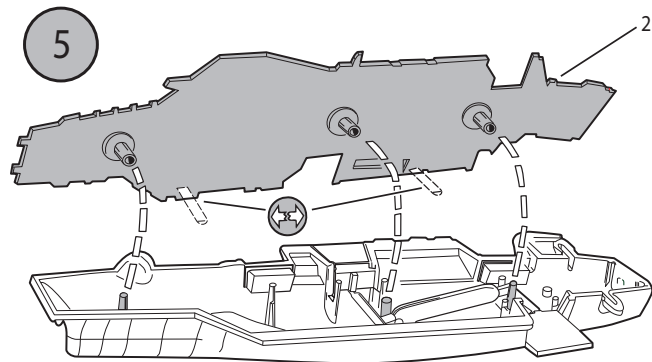

④ + 2

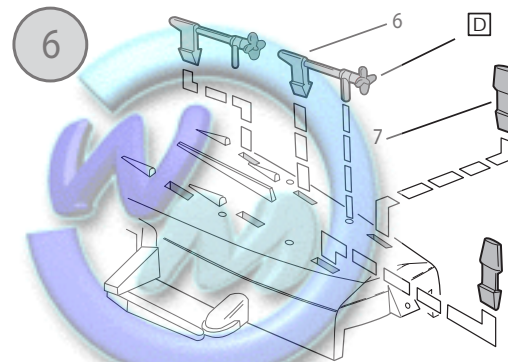

⑤ + 6 + 6 + 6 + 6 + 7 + 7

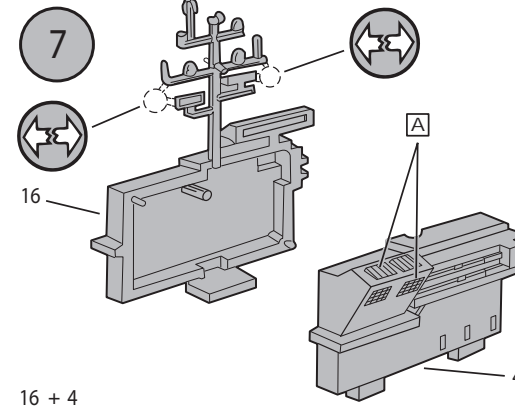

16 + 4

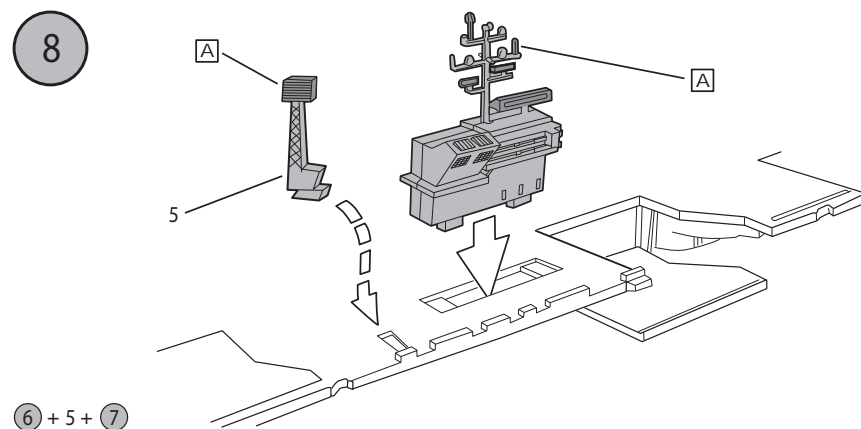

⑥ + 5 + 7

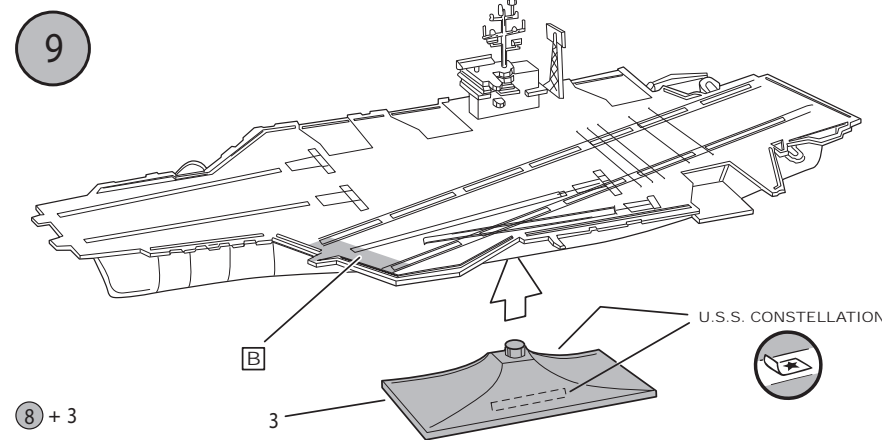

⑧ + 3