



# Fast Attack Craft / Schnellboot S-100 & Flak 38

05002-0389

© 2006 by REVELL GmbH &amp; Co. KG.

PRINTED IN GERMANY

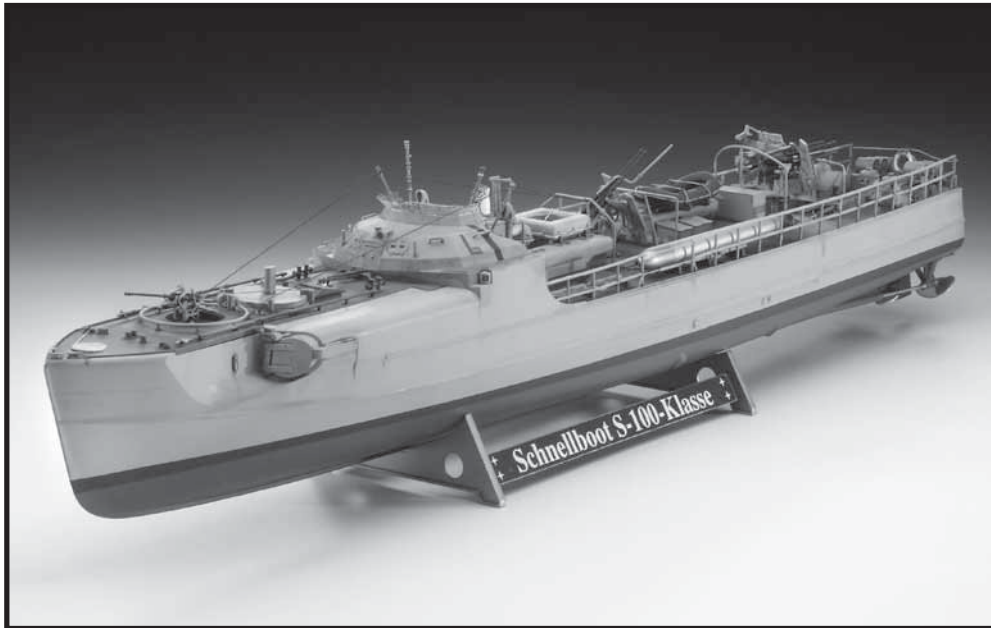

## Fast Attack Craft / Schnellboot S-100 & Flak 38

Der Schiffwerft Friedrich Lürssen / Vegesack war es gelungen, der deutsche Marine im 2. Weltkrieg einen schnellen, seetüchtigen und überlegenen Schnellboottyp zur Verfügung zu stellen. Selbst bei schwerer See erlaubte er Höchstgeschwindigkeit, besaß glänzende Manöviereigenschaften und erforderte aufgrund seiner ausgewogenen Konstruktion bis zum Kriegsende keine grundsätzlichen Änderungen der Bootsform.

Die S-100-Bewaffnung bestand aus 2 fest eingebauten Torpedorohren von 53,3 cm-TR (Torpedo G7A) und insgesamt 4 Torpedos.

Zur Regelbewaffnung gehörten 2 2 cm-Maschinenwaffen (Flak 38) mit bis zu 6000 Schuss Munition, davon eine in versenkbarer Drehkranzlafette 41 auf dem Backdeck und eine auf dem Achterdeck sowie (ab etwa 1943) einem 2cm-Zwillings-MG im Mitschiffsbereich.

Ab 1943 erfolgte eine sukzessive Nachrüstung durch eine achtern eingebaute Bordkanone 3,7 cm Flak 36 oder eine vollautomatische 4cm-Bofors-Flak 28 mit bis zu 2000 Schuss Munition, die je nach Verfügbarkeit auf den S-100 - Booten vertreten waren. Zusätzlich wurden 2 MG 34 (später auch provisorisch MG 42) auf der Brücke mitgeführt.

1944/45 wurden achtern teilweise ein 2 cm-Flak-Vierling C38 installiert, der sich bei Gefechten mit offensiven Gegnereinheiten sehr bewährte. Gegnerische Luftangriffe mit Bordwaffen, Bomben und Raketen im Kanal, Atlantik und Ostsee konnten mit diesem gefürchteten Flak-Vierling mit hoher Feuerkadenz erfolgreich bekämpft werden.

Obwohl die S-Boote speziell als Torpedoboote konzipiert waren, erfüllten sie auch heikle Transportaufgaben oder fanden als schnelle Minenleger Verwendung. Für die U-Jagd waren sie auch mit Wasserbomben bestückt. Die größte Bedrohung erwuchs der Schnellbootwaffe 1944/45 durch die Radarortungs- und Feuerleittechnik der alliierten Geleit- und Sicherungsfahrzeuge und durch radargestützte Luftangriffe auch bei Nacht, da geeignete Abwehrtechnik obwohl bereits existent - bis Kriegsende nur noch ausnahmsweise nachgerüstet wurde.

Die Marineliteratur verweist darauf, dass die Ausstattung mit dem Flak-Vierling nach Maßgabe der tatsächlich verfügbaren Waffen erfolgte und nicht selten von der Findigkeit der Marinewerften, der Bootskommandanten und ihren Besatzungen abhängig war. So führten gegen Kriegsende einige S-Boote den Flak-Vierling, obwohl er bei Übergabe der Frontboote nicht zur wertseitigen „Erstbewaffnung“ gehörte.

Der spezielle S-100 -Typ bot den Besatzungen trotz Kriegsbedingter Engpässe ein schlagkräftiges Waffensystem mit hoher Einsatzfähigkeit, Erfolgsmöglichkeit und Überlebenswahrscheinlichkeit. Dabei wurde der Flak-Vierling zur Sicherung vieler Operationen eine wirksame Abwehrwaffe, die sich bei den Ostsee-Evakuierungsaktionen 1945, im Nachteinsatz, in umkämpften Hafengebieten sowie dicht unter Land und nicht selten im Feuerbereich der Gegner hervorragend bewährte.

Die deutschen S-Boote konnten sich bis zum Ende des Krieges durch überlegene Geschwindigkeit, hohe Manöviereigenschaften und gute Bewaffnung behaupten und stellen dadurch eine ständig wirksame, kräftebindende Bedrohung für die Schifffahrt der Gegner dar.“

### Technische Daten:

**Bauwerften:** u.a. Lürssen/Vegesack, Gusto N.V./Schiedam und Schlichting/Travemünde.

**„S-100“-Typ:** Länge 34,94 m, Breite 5,28 m, Höhe 2,90 m, Tiefgang 1,67 m

**Konstruktionswasserverdrängung:** 98,91t, Einsatzverdrängung: bis 110,74 t.

**Fahrbereich:** zwischen 700 sm - 750 sm.

**Antrieb:** Anfangs 3 Daimler-Benz MB 511-V Viertakt-Diesels zu je 2000 PS (später je 3 MB 501A oder MB 511 mit zusammen ca. 7500 PS Leistung bei mechanischer Aufladung) Antrieb auf 3 Hochgeschwindigkeits-Schrauben von 1,10 oder 1,23 m Durchmesser.

**Geschwindigkeit:** 43,5 Knoten, kurzfristig bis 48 Knoten.

**Besonderheiten:** 1 Halbbalance-Ruder mit 2 seitlichen Staurudern im Schraubenstrom der äußeren Schraubenwellen, - verantwortlich für besonders gute Manöviereigenschaften und eine zusätzliche Geschwindigkeitserhöhung Dank des sog. „Lürssen-Effekts“.

107 „überlebende“ S-Boote wurden unter den Siegermächten als willkommenes Kriegsbeute aufgeteilt und verrichteten in vielen Marinen (England, Dänemark, Russland, u.a. auch Bundesmarine) noch lange ihren Dienst.

## Fast Attack Craft / Schnellboot S-100 & Flak 38

During the Second World War it was thanks to the Friedrich Lürssen Shipyard at Vegesack that the German Navy received a fast and sea-worthy "Schnell Boot" (Fast Patrol Boat) of superior design. The balanced construction permitted maximum speed and brilliant manoeuvrability even in heavy seas and no major changes to the basic design were needed right up until the end of the war.

The normal armament of the S-100 consisted of two fixed 53.3 cm TR torpedo tubes with a total of four G7A torpedos and two 2cm Flak 38 machine guns with up to 6000 rounds of ammunition. One in a retractable rotating Crescent Mount 41 on the rear-deck and one on the after-deck. Later (about 1943) a mid-ships mounted twin 2cm machine gun was also fitted. After 1943 there followed a gradual re-arming program whereby as availability dictated the S-100 received an aft mounted 3.7 cm Flak 36 Canon or a fully automatic 4cm Bofors Flak 28 with up to 2000 rounds of ammunition. Additionally, two MG34 machine guns (later provisionally MG42) were also mounted on the Bridge. During 1944/45 a 2 cm C38 Quad-Flak which proved to be very effective in action against offensive enemy units was sometimes fitted astern. Enemy air attacks with guns, bombs and missiles in the English Channel, the Atlantic and the Baltic Sea were successfully fought off with this feared Quad-Flak with its high rate of fire.

Although the S-Boats were specifically conceived as Torpedo Boats, they were also used for dedicated transport tasks, or found use as fast minelayers. They were sometimes equipped with depth-charges when submarine hunting. The greatest threat to the Fast Patrol Boats came in 1944/45, both by day and night from the Acquisition and Fire Control Radar of the Allied Convoy Escort and Protection Ships and Radar directed air attacks. Suitable defensive technology although readily available was only fitted in exceptional circumstances right up until the end of the war.

Marine literature refers to the fact that the Quad Flak was fitted according to the availability of the weapon and often the ingenuity of the shipyards on whom the ships captains a crews depended. Towards the end of the war therefore, some S-Boats carried the Quad Flak even though it did not belong to the initial weaponry installed by the shipyard prior to delivery.

The later Type S-100 offered the crews a powerful weapons system with a high operational effectiveness, and a high chance of success and survival despite bottle-necks caused by the war. The Quad-Flak became an effective defensive weapon in securing many operations. It gave an excellent account of itself in the Baltic Evacuation actions of 1945, during night action in hard fought over harbour areas as well as close inshore and often within the arcs of enemy fire. Through superior speed, manoeuvrability and weaponry the German "Schnell Boats" were able to assert themselves right up to the end of the war and posed a constant and effective combined threat to enemy shipping.

### Technical Data:

**Shipyards:** Various including Lürssen of Vegesack, Gusto N.V. of Schiedam, and Schlichting of Travemünde.

**„S-100“-Typ:** Length: 34.94 m (12 ft 11 ins), Width: 5.28m (17 ft 3 ins), Height: 2.90 m (9 ft 6 ins), Draught: 1.67 m (5 ft 6 ins)

**Displacement Empty:** 98.91 t, Displacement in Action: up to 110.74 t.

**Range:** 700 nm - 750 nm.

**Power-Units:** Initially 3 X Daimler-Benz MB511-V 4 stroke diesels each developing 2000 hp (later either 3 X MB 501A or MB511 with a total of about 7500 hp using mechanically driven supercharging) driving three high speed propeller's of 1.10 m or 1.23 m diameter.

**Speed:** 43.5 Knots, short sprint 48 Knots.

**Special Features:** One Half-balance Rudder with two variable pitch rudders in the propeller wake of the outer propeller shafts giving excellent manoeuvrability and an extra turn of speed due to the "Lürssen Effect".

107 surviving "S-Boats" were divided up between the Allied Powers as welcome reparations after the war and saw lengthy service in the Naval Forces of many countries including England, Denmark, Russia and the Federal German Navy.

Form hergestellt im Eigentum von Revell GmbH & Co. KG. Widerrechtliche Nachahmungen werden gerichtlich verfolgt.

Co produit est propriété de la société Revell GmbH & Co. KG. Toute utilisation ou duplication frauduleuse fera l'objet de poursuites en justice.

Modelado y en propiedad de Revell GmbH & Co. KG. Imitaciones ilícitas serán perseguidas por la ley.

Forma prodotta dalla Revell GmbH & Co. KG. e di proprietà della stessa impresa, la quale procederà legalmente contro ogni imitazione abusiva.

Modeli on Revell GmbH & Co. KG. valmistama ja omaisuuna. Laittomuuta kopiointiin tullaan puuttamaan oikeusellisin toimin.

Design utviklet av og eies av Revell GmbH & Co. KG. Etterligning uten tillatelse blir gjenstand for rettslig forfølgelse.

Prodotto a prava vlasnosti firmy Revell GmbH & Co. KG. Nijelagodne podrobienie jest zabronione pod opowiadzalnoscia sadowna.

Model, Revell GmbH & Co. KG. firmasının mülkiyeti altında imal edilmiştir. Kanuna aykırı taklitler mahkemece takibi edilecektir.

A forma előállításja és tulajdonjog bírkozza a Revell GmbH & Co. KG. A jogellenes utánahozatok és hamisítványokak bíróságiilag üldöztek.

Mould manufactured by and property of Revell GmbH & Co. KG. Illegal imitations are subject to prosecution.

Vorm vervaardigd door en eigendom van Revell GmbH & Co. KG. Onrechtmatige nabootsingan worden gerichtlich vervolgd.

Formas produzidas e de propriedade da Revell GmbH & Co. KG. Cópias não autorizadas serão processadas juridicamente Como determinado na lei.

Modellen tillverkad av och tillhör Revell GmbH & Co. KG. All kopiering bolvms enligt lagen om upphovsrätt.

Formen er fremstillet af Revell GmbH & Co. KG. som også har ejendomsret. Lovstridige efterligninger sagsøges.

Модель изготовлена и выдается собственностию фирмы Revell GmbH & Co. KG. Противозаконные подделки преследуют и выдается в судебном порядке.

Η μορφή κατασκευαστηκε και περιηλε ιδιοκτησια της Revell GmbH & Co. KG. Οι παρανομες μιμησεις θα καταδικωνται δικαστικως.

Tvár byl vyhovra firmou Revell GmbH & Co. KG. a je jejím vlastnictvím. Proti nezákonným napodobením se bude postupovat soudní cestou.

Forma je proizvedena in je vlasnistvo Revell GmbH & Co. KG. Neovlascene kopije bodo pravno kaznjene.



## Verwendete Symbole/Used Symbols

Bille beskriver Sie følgende Symbole, die in den nachfolgenden Baustufen verwendet werden.  
**Veillez noter les symboles indiqués ci-dessous, qui sont utilisés dans les étapes suivantes du montage.**  
 Sirvise tener en cuenta los símbolos facilitados a conti naci3n, a utilizar en las siguientes fases de construcci3n.  
**Si prega di fare attenzione ai seguenti simboli che vengono usati nei susseguenti stadi di costruzione.**  
 Huomii seuravat symbolit, j3ita k3ytett3n seuraavissa kokoomsvaiheissa.  
**Leggemy til symbolene som benyttes i monteringsstapene som følger.**  
 Prosz3 zwr3cać na nast3puj3ce symbole, kt3re s3 uzyte w pon3szych etapach monta¿owych  
**Daha sonraki montaj basamaklarında kullanilacak olan, aŖag3daki sembollere l3ften dikkat edin.**  
 K3rj3k, hogy a k3vetkez3 szimb3liumokat, melyek az al3bbi 3pl3si lokokban alkalmaz3sra ker3lnek, vegy3k figyelembe.

Please note the following symbols, which are used in the following construction stages.  
**Neem a.u.b. de volgende symbolen in acht, die in de onderstaande bouwfasen worden gebruikt.**  
 Por favor, presta atenci3n a los s3mbolos que se guarn a p3is, os mismos ser3n usados nas pr3ximas etapas de montagem.  
**Observera: Nedanst3ende piktogram anv3nds i de f3ljande arbetsmomenten.**  
 L3eg ven i g3t merke til f3ljende symboler, som benyttes i de la g3nde byggestr3p.  
 Pokazuj3te, obr3tite vniimanje na sleduju3ne symbole, kt3rye ispol3zuj3te v nasleduju3mii operacii sbr3rk.  
 Παρακαλ3ω προσ3ξετε τα παρακάτω s3μβολα, τα οποία χρησιμοποιούνται στις παρακάτω β3θμιας συναρμολ3γησης  
**Dbejte pros3m na d3le uveden3 symboly, kt3re se pou¿iv3ji v n3sleduj3c3ch konstruckn3ch stupn3ch.**  
 Prosim3 za VaŖu pozornost na sled3e3ce symbole ki se uporabljajo v naslednj3h korakih gradbe.



Kleben  
 Glue  
 Colleur  
 Lijmen  
 Engomar  
 Colar  
 Incollare  
 Limmas  
 Limaa  
 Kl3bning  
 Lim  
 Κλεπτις  
 Przyklei3ć  
 Κ3λλημα  
 YapıŖtırma  
 Lepeni  
 ragasztani  
 Lepiti



Nicht kleben  
 Don't glue  
 Ne pas colleur  
 Niet lijmen  
 No engomar  
 N3o colar  
 Non incollare  
 Limmas ej  
 A3a limaa  
 M3 ikke kl3bnes  
 Ikke lim  
 Не клеπтиς  
 Nie przyklei3ć  
 μη κ3λλημα  
 YapıŖtırma yin  
 Nelepit  
 nem szabad ragasztani  
 Ne lepiti



Wahlweise  
 Optional  
 Facultatif  
 Naar keuze  
 No engomar  
 Alternado  
 Facoltativo  
 Valfritt  
 Vaihtoehdoisesti  
 Efer eget valg  
 Valgfritt  
 Ha v3lbor  
 Do wyboru  
 enallaktik3  
 Seçmeli  
 Voitelt3n3  
 tetsz3s szerint  
 na3in izbire



Anzahl der Arbeitsg3nge  
 Number of working steps  
 Nombre d'3tapes de travail  
 Het aantal bouwstappen  
 N3mero de operaciones de trabajo  
 N3mero de etapas de trabalho  
 Numero di passaggi  
 Antal arbetsmoment  
 Ty3v3rheiden lukum33r3  
 Antal arbeidsfor3b  
 Antall arbeidstrinn  
 Κοπικησθη οπαρασι3ν  
 Liczba operacii  
 αριθμ3ς των εργασι3ν  
 Is sahalainnin sayis  
 Počet pracovn3ch operacii  
 munkafolyamatok sz3ma  
 Ŗtevilka koraka monta¿e



Abziehbild in Wasser einweichen und anbringen  
 Soak and apply decals  
 Mouiller et appliquer les d3calcomanies  
 Transfer in water even laten weken en aanbrengen  
 Remojar y aplicar las calcomanias  
 P3r de molho em 3gua e aplicar o decalque  
 Immergere in acqua ed applicare decalcomanie  
 Bl3t och l3st dekalerna  
 Kostluta siirtokuva vedess3 ja aseta paikall3en  
 Overf3ringsbilledet l3gges i bl3d og anbringes  
 Dypp bildet i vann og sett det p3  
 Переводную картинку намочить и нанести  
 Zm3kczyc kalkomanie w wodzie a nast3pnie naklei3ć  
 βουτ3ξετε τη χ3λκομανια στο νερο και τοποθετειστε την  
 Çikartmayı suda yumuŖatın ve koyun  
 Obtisk namo3it ve vod3 a umistit  
 a matric3t v3zben be3ztatni 3s felhelyezni  
 Preslik3ak potopiti v vodo in zatem nanaŖati



Bautelle trocken lassen  
 Laisser s3cher les pi3ces  
 Dejar secar las piezas  
 Dekar secar os componentes  
 La delene torke  
 Allow the parts to dry  
 Oderdelen laten drogen  
 Far asciugarsi i componenti  
 Anna osien k3lvua  
 L3t byggdelarna torka  
 Lad komponenterne tørre  
 Cz3sci pozostawic do wyschniecia  
 Yapi parçalarını kurumaya birakiniz  
 Jednotliv3 díly nechte zaschnout  
 Αρρωστε τα μερη να στεγνωσουν  
 Alkatr3szeket hagyja sz3radni  
 Pustite da sestavni deli posuŖijo  
 Дать деталям высохнуть



Klebeband  
 Adhesive tape  
 D3vid3o de ruban adh3siv  
 Plakband  
 Cinta adhesiva  
 Fita adesiva  
 Nastro adesivo  
 Tejp  
 Teippi  
 Tape  
 Tape  
 Клейкая лента  
 TaŖma klej3ca  
 κ3λλητικ3 ταινια  
 YapıŖtırma bandı  
 Lepici p3ska  
 ragaszt3szalag  
 Traka z lepliom



Mit einem Messer abtrennen  
 Detach with knife  
 D3tacher au couteau  
 Met een mesje afsnijden  
 Separarlo con un cuchillo  
 Separar utilizando uma faca  
 Staccare col coltello  
 Sk3r loss med kniv  
 Irrota veitsell3  
 Adskilles med en kniv  
 Skj3r av med en kniv  
 Otdel3t' no¿om  
 Oddci3ć no¿em  
 διαχωριστε με 3να μαχαίρι  
 Bir b3çak ile kesin  
 Odd3lit pomoci no¿e  
 k3s segits3g3vel lev3lasztani  
 Oddeliti z no¿em



Abbildung zusammengesetzter Teile  
 Illustration of assembled parts  
 Figure representant les pi3ces assembl3es  
 Afbeelding van samengevoegde onderdelen  
 Ilustraci3n piezas ensambladas  
 Figura representando peç3s encaixadas  
 Illustrazione delle parti assemblate  
 Bilden visar d3larna hopsatta  
 Kuva yhteenliitetyst3 osista  
 Illustration af sammensatte dele  
 Ilustrasjon, sammensatte deler  
 Изображение смонтированных деталей  
 Rysunek zlo¿onych cz3sci  
 απεικ3νιση των συναρμολογημ3νων εξαρτημ3των  
 Birlesürülen parçaların Ŗekli  
 Zobrazen3 sestaven3ch dílů  
 3ssze3llit3tt alkatr3szek 3br3ja  
 Slika slopljenega dela



Loch bohren  
 Make a hole  
 Faire un trou  
 Maak een gat  
 Praclicar un taladro  
 Perfurar  
 Fare un foro  
 Borra h3l  
 Poraa reik3  
 Der bores et hul  
 Bor hull  
 Просверлить отверстие  
 wywierci3 3tw3r  
 ανοι¿ετε τρύπα  
 Delik açın  
 Vyvrtat diru  
 lyukat f3rni  
 Narediti lukinjo



Entfernen  
 Remove  
 D3tacher  
 Verwijderen  
 Sacar  
 Retirar  
 Eiminare  
 Tag loss  
 Poista  
 Fjernes  
 Fjern  
 Удалить  
 Usun3ć  
 απομακρ3νετε  
 Temizleyin  
 Odstranit  
 elt3voiltani  
 Ostraniti



Gleichen Vorgang auf der gegenüberliegenden Seite wiederholen  
 Repeat same procedure on opposite side  
 Op3rer de la m3me taç3n sur l'autre face  
 Dezelfde handeling herhalen aan de tegenoverliggende kant  
 Realizar el mismo procedimiento en el lado opuesto  
 Repetir o mesmo procedimento utilizado no lado oposto  
 Stessa procedura sul lato opposto  
 Upprepa proceduren p3 motsatta sidan  
 Toista sama toimenpide k3ten viereisell3 sivulla  
 Det samme arbejde gentages p3 den mods3tliggende side  
 Gjenta prosedyren p3 siden tv3rs overfor  
 Повторять такую же операцию на противоположной стороне  
 Taki sam przebieg czynn3ci powt3rzyć na stronie przeciwn3j  
 επαναλ3βετε την ίδια διαδικασια στην απ3ναντι πλευρ3  
 Aynı islemi karŖı tarafta tekrarlayın  
 Stejn3 postup zopakovat na protilehl3 stran3  
 ugyanazt a folyamatot a szemben tal3lhat3 oldalon megism3telni  
 Isti postopek ponoviti in na suprotni strani



Brauen Faden benutzen  
 Use brown thread  
 Employer le fil brun  
 Gebruik bruine draad  
 Utilizar hilo marr3n  
 Utilizar fio castanho  
 Usare filo marrone  
 Anv3nd bruna tr3dar  
 K3yt3 ruskeaa lankaa  
 Benyt en brun tr3d  
 Bruk brun tr3d  
 Исползовать коричневые нитки  
 Uzyć brazowej nici  
 χρησιμοποιειστε την καφ3 κλωστ3  
 Kahverengi iplik kullanın  
 Pou¿it hnd3 vl3kno  
 barna fonalat kell haszn3lni  
 Uporabl3jati rjavi nit



Anknoten und Kleben  
 Tie and Glue  
 Attacher et Colleur  
 Vastknopen en Lijmen  
 Atar y Engomar  
 Anudar e Colar  
 Annodare e Incollare  
 Knyt fast och Limmas  
 Solmi ja Limaa  
 Bindes fast og Kl3bning  
 Knyt og Lim  
 Sv3zatz uzlom i Kлептиς  
 Przywi3zać oraz Przyklei3ć  
 κομπ3δεστε και κ3λλημα  
 Dű¿mleyin ve YapıŖtırma  
 Nauzlit a Lepeni  
 megcsom3zni 3s ragasztani  
 Zavezati in Lepiti

**D:** Beiliegenden Sicherheitstext beachten und nachschlagebereit halten.

**E:** Please note the enclosed safety advice and keep safe for later reference.

**F:** Respecter les consignes de s3curit3 ci-jointes et les conserver 3 port3e de main.

**NL:** Houdt u aan de bijgaande veiligheidsinstructies en hou deze steeds bij de hand.

**E:** Observar y siempre tener a disposici3n este texto de seguridad adjunto.

**I:** Seguire le avvertenze di sicurezza allegate e tenerle a portata di mano.

**P:** Ter em atenç3o o texto de segurança anexo e guard-lo para consulta.

**S:** Beakta bifogad s3kerhetstext och h3ll den i ber3dskap.

**FIN:** Huomii ja s3ilyt3 oheiset varoitukset.

**DK:** Overhold vedlagte s3kerhedsanvisninger og hav dem liggende i n3rheden.

**N:** Ha alltid vedlagt sikkerhetstekt klar til bruk.

**RUS:** Соблюдать прилагаем3й текст по технике безопасности, хранить его в легко доступном месте.

**PL:** Stosować si' do załączonej karty bezpieczeŖstwa i miec j3 stale do wgl3du.

**GR:** ποσ 3τε τις συνημμ νεσ υποδειξεις ασ 3λειας και υλ3ξετε τις ται 3στε να τις χτε παντα σε διαθ ση σ3ς.

**TR:** Ekteki g3venlik talimatlarını dikkate alıp, bakabileceginiz bir sekilde muafaza ediniz.

**CZ:** Dbejte na pfiilo3en' bezpe3nostn3 text a m3jte jej pfiipraven' na dosah.

**H:** A mell3kelt biztons-gi sz3veget vegye figyelembe 3s tartsa fellapoz-sra k3sz3n!

**SL0:** Pril3lena varnostna navodila izvajajte in jih hranite na vsem dostopnem mestu.

05002

## Benötigte Farben/Used Colours

Bendigte Farben Required colours	Peintures nécessaires Benötigte kleuren	Pinturas necesarias Tintas necessárias	Colori necessari Använda färger	Tarvittavat värit Du trenger følgende farger	Neobходимые краски	Potrzebne kolory Αποτιθέμενα χρώματα	Gerekli renkler Potrebne barvy	Szükséges színek. Potrebne barve						
<b>75%</b> <b>A</b> <b>25%</b>	<b>rost, matt 83</b> rust, matt rouille, mat roest, mat orin, mate ferrugem, fosco color ruggine, opaco rost, matt ruoste, himmeä rust, mat rust, matt ржавчина, матовый rdzawy, matowy χρώμα σκουριάς, ματ pas rengi, mat rezavá, matná rozszda, matt rjava, mat	<b>braun, matt 85</b> brown, matt brun, mat bruin, mat marrón, mate castanho, fosco marrone, opaco brun, matt ruskea, himmeä brun, mat brun, mat хоричневый, матовый brązowy, matowy кафэ, мац kahverengi, mat hnědá, matná barna, matt rjava, mat	<b>staubgrau, matt 77</b> dust grey, matt gris poussière, mat stofgrijs, mat ceniciento, mate cinzento de pó, fosco grigio sabbia, opaco brun, matt pölynharma, himmeä støvgrå, mat støvgrå, matt серый пыльный, матовый szary kurz, matowy χρώμα σκόνης, ματ toz grisi, mat prachově šedá, matná porszürke, matt prah siva, mat	<b>75%</b> <b>D</b> <b>25%</b>	<b>siber, metallic 90</b> + silver, metallic argent, métallique zilver, metallic plata, metalizado prata, metálico argento, metallico silver, metallic hopea, metallikiitto sølv, metallak sølv, metallic серебристый, металл srebro, metaliczny ασήμι, μεταλλικό gümüş, metalik stříbrná, metaliza ezüst, metáll srebrna, metalik	<b>messing, metallic 92</b> brass, metallic laiton, métallique messing, metallic latón, metalizado latão, metálico ottone, metallico mässing, metallic messinki, metallikiitto messing, metallak messing, metallic латунный, металл mosiądz, metaliczny ορείχαλκου, μεταλλικό pirinç, metalik mosazná, metaliza sárgaréz, metáll mesing, metalik	<b>E</b>	<b>steingrau, matt 75</b> stone grey, matt gris pierre, mat steengrijs, mat gris pizarra, mate cinzento pedra, fosco grigio roccia, opaco stengrå, matt kivenharma, himmeä stengrå, mat steingrå, matt серый каменный, матовый szary kamien., matowy γκρι πέτρας, ματ tas grisi, mat kameně šedá, matná kőszürke, matt kamen siva, mat	<b>F</b>	<b>anthrazit, matt 9</b> anthracite grey, matt anthracite, mat antraciet, mat antracita, mate antracite, fosco antracit, matt antrasitiit, himmeä koksgrå, mat antrasit, mat антрацит, матовый antracyt, matowy ανθρακί, ματ antrasit, mat antracit, matná antracit, matt tamno siva, mat				
<b>50%</b> <b>G</b> <b>50%</b>	<b>grau, matt 57</b> + grey, matt gris, mat grijs, mat gris, mate cinzento, fosco grigio, opaco grå, matt harmaa, himmeä grå, mat grå, matt серый, матовый szary, matowy γκρι, ματ grí, mat šedá, matná szürke, matt siva, mat	<b>weiß, matt 5</b> white, matt blanc, mat wit, mat gris, mate branco, fosco bianco, opaco vít, matt valkoinen, himmeä grå, mat hvit, matt белый, матовый biały, matowy λευκό, ματ beyaz, mat bílá, matná fehér, matt bela, mat	<b>75%</b> <b>H</b> <b>25%</b>	<b>rost, matt 83</b> + rust, matt rouille, mat roest, mat orin, mate ferrugem, fosco color ruggine, opaco rost, matt ruoste, himmeä rust, mat rust, matt ржавчина, матовый rdzawy, matowy χρώμα σκουριάς, ματ pas rengi, mat rezavá, matná rozszda, matt rjava, mat	<b>eisen, metallic 91</b> steel, metallic coloris fer, métallique ijzerkleurig, metallic ferroso, metalizado ferro, metálico ferro, metallico járnfärg, metallic teräksenvärinen, metallikiitto jern, metallak jern, metallic стальной, металл żelazo, metaliczny σιδηρού, μεταλλικό demir, metalik železná, metaliza vas, metáll železna, metalik	<b>I</b>	<b>feuerrot, seidenmatt 330</b> fiery red, silky-matt rouge feu, satiné mat rood helder, zijdemat rojo fuego, mate seda vermelho vivo, fosco sedoso rosso fuoco, opaco seta eldröd, sidenmatt lulipunalainen, silkinhimeä ildröd, silkematt ildröd, silkematt огненно-красный, шелк-матовый czerwony ognisty, jedwabisto-mat. κόκκινο φωτιάς, μεταξωτό ματ ateş kırmızı, ipek mat ohnivě červená, hedvábně matná tűzpiros, selyemmatt ogenj rdeča, svila mat	<b>J</b>	<b>seegrün, matt 48</b> sea green, matt vert d'eau, mat zeegroen, mat verde mar, mate verde-mar, fosco verde lago, opaco havsgrön, matt merenvihreä, himmeä havgrøn, mat sjøgrønn, matt зеленый морской, матовый zieleń morska, matowy πράσινο λίμνης, ματ göl yeşili, mat mořská zelená, matná fengerzöld, matt morsko zelena, mat	<b>K</b>	<b>weiß, matt 5</b> white, matt blanc, mat wit, mat blanco, mate branco, fosco bianco, opaco vít, matt valkoinen, himmeä hvid, mat hvit, matt белый, матовый biały, matowy λευκό, ματ beyaz, mat bílá, matná fehér, matt bela, mat	<b>L</b>	<b>karmirod, matt 36</b> carmin red, matt rouge carmin, mat karmijnrood, mat carmin, mate vermelho carmin, fosco rosso carminio, opaco karmínröd, matt karminipurainen, himmeä karmínröd, matt karmínröd, matt красный кармин, матовый karmínowy, matowy κόκκινο δαίηδό, ματ lál rengi, mat krbově červená, matná kárminpiros, matt šrninka rdeča, mat	
<b>90%</b> <b>M</b> <b>10%</b>	<b>gelb, matt 15</b> + yellow, matt jaune, mat geel, mat amarillo, mate amarelo, fosco giallo, opaco gul, matt keltainen, himmeä gul, mat gul, matt желтый, матовый żółty, matowy κίτρινο, ματ sari, mat žlutá, matná sárga, matt rumena, mat	<b>grau, matt 57</b> grey, matt gris, mat grijs, mat gris, mate cinzento, fosco grigio, opaco grå, matt harmaa, himmeä grå, mat grå, matt серый, матовый szary, matowy γκρι, ματ grí, mat šedá, matná szürke, matt siva, mat	<b>75%</b> <b>N</b> <b>25%</b>	<b>anthrazit, matt 9</b> + anthracite grey, matt anthracite, mat antraciet, mat antracita, mate antracite, fosco antracit, matt antrasitiit, himmeä koksgrå, mat antrasit, mat антрацит, матовый antracyt, matowy ανθρακί, ματ antrasit, mat antracit, matná antracit, matt tamno siva, mat	<b>eisen, metallic 91</b> steel, metallic coloris fer, métallique ijzerkleurig, metallic ferroso, metalizado ferro, metálico ferro, metallico járnfärg, metallic teräksenvärinen, metallikiitto jern, metallak jern, metallic стальной, металл żelazo, metaliczny σιδηρού, μεταλλικό demir, metalik železná, metaliza vas, metáll železna, metalik	<b>34%</b> <b>O</b> <b>66%</b>	<b>silber, metallic 90</b> + silver, metallic argent, métallique zilver, metallic plata, metalizado prata, metálico argento, metallico silver, metallic hopea, metallikiitto sølv, metallak sølv, metallic серебристый, металл srebro, metaliczny ασήμι, μεταλλικό gümüş, metalik stříbrná, metaliza ezüst, metáll srebrna, metalik	<b>messing, metallic 92</b> brass, metallic laiton, métallique messing, metallic latón, metalizado latão, metálico ottone, metallico mässing, metallic messinki, metallikiitto messing, metallak messing, metallic латунный, металл mosiądz, metaliczny ορείχαλκου, μεταλλικό pirinç, metalik mosazná, metaliza sárgaréz, metáll mesing, metalik	<b>P</b>	<b>geschützgrau, matt 74</b> gunship grey, matt gris canon, mat gedekt grijs, mat cañón gris, mate cinzento-canhão, mate grigio cannone, opaco kanongrå, matt armeijanharmaa, matta kanongrå, mat kanongrå, matt орудийно-серый, матовый armatni szary, matowy γκρι στρατιωτικό, ματ askeri gri, mat hadihajó szürke, matt olovně šedivá, matná zaščitnosiva, brez leska	<b>Q</b>	<b>silber, metallic 90</b> silver, metallic argent, métallique zilver, metallic plata, metalizado prata, metálico argento, metallico silver, metallic sølv, metallak sølv, metallic серебристый, металл srebro, metaliczny ασήμι, μεταλλικό gümüş, metalik stříbrná, metaliza ezüst, metáll srebrna, metalik	<b>R</b>	<b>grau, matt 57</b> grey, matt gris, mat grijs, mat gris, mate cinzento, fosco grigio, opaco grå, matt harmaa, himmeä grå, mat grå, matt серый, матовый szary, matowy γκρι, ματ grí, mat šedá, matná szürke, matt siva, mat

Dieser Bausatz wurde in mehrfachen Qualitäts- und Gewichtskontrollen auf Vollständigkeit überprüft. Reklamationen können nur bearbeitet werden, wenn die **Bauanleitung**, das aus der Kartonage herausgeschittene **EAN-Strichcode-Feld** und der **Kassenbon** eingeschickt werden. Bitte haben Sie Verständnis dafür, dass wir nur Gewährleistung bei aktuellen Artikeln übernehmen können, die im Zeitraum der letzten 24 Monate erworben worden sind. **Unfrei eingesandte Reklamationssendungen werden von uns nicht angenommen!** „Einzelteile für Umbauten können gegen Vorkasse erworben werden“. Unsere Adresse: Revell GmbH & Co. KG, Abteilung X, Henschelstr. 20-30, 32257 Bünde. Dieser Direktservice gilt für die Länder: Deutschland, Benelux, Österreich, Frankreich, Großbritannien. Reklamationen aus den übrigen Ländern werden über die jeweiligen Distributeure abgewickelt. Bitte kontaktieren Sie Ihren Händler.

*This Model Kit has been subject to extensive quality and weight checks during the manufacturing process to ensure it leaves our warehouse in perfect condition. We are only able to process applications for missing parts if the following procedure is followed. In all cases the following will be required before we are able to process any request: Original receipt (proof of purchase) original instruction sheets (will be returned) and the bar code cut out of the box. We may not be able to process requests for products that have been discontinued for more than 24 months. Products that are returned directly to us without prior authorisation by a company representative will not be accepted and returned to sender. Replacement parts for conversion or spares will continue to be available however they will incur a handling charge. Please write to: Abteilung X, Revell GmbH & Co. KG, Henschelstr 20-30, 32257 Bünde. This direct service is only available in the following markets: Germany, Benelux, Austria, France & Great Britain, Revell GmbH & Co. KG, Boston Houso, 64-66 Queensway, Hemel Hempstead, Herts, HP2 5HA, Great Britain. For all other markets please contact your local dealer or distributor directly.*

Afin de vous donner entière satisfaction et pour nous assurer que tous les éléments nécessaires au montage de votre maquette sont présents dans la boîte, cet article a subi dans son intégralité divers contrôles qualité afin que des contrôles de poids. Si toutefois vous deviez nous faire part de certaines réclamations, nous vous prions de bien vouloir vous adresser à votre revendeur habituel, muni de la notice de montage, du code EAN découpé sur la boîte, ainsi que de votre ticket de caisse. Le SAV ne sera assuré que pour les articles ayant été acquis depuis moins de 24 mois. Les pièces de rechange utilisées pour la transformation de maquettes pourront être obtenues en pré-paiement. Dans le cas où vous n'obtiendriez pas satisfaction, vous pouvez vous adresser directement à notre service SAV à l'adresse suivante: REVELL GmbH & Co. KG, Abteilung X, Henschelstraße 20-30, D-32257 Bünde ou Revell GmbH & Co. KG, 14 B, rue du Chapeau Rouge, F-21000 Dijon, France. Pour tous les autres marchés, merci de prendre contact avec votre détaillant ou distributeur.

*Deze bouwdoos werd verscheidene malen volledig gecontroleerd op kwaliteit en gewicht. Klachten kunnen slechts in behandeling worden genomen indien de bouwhandleiding, de uit de doos geknipte EAN- streepjescode en de kassabon zijn meegestonden. Wij vragen om uw begrip dat wij alleen garantie kunnen geven voor huidige artikelen die binnen een periode van de laatste 24 maanden zijn gekocht. Onvolledig ingezonden klachten kunnen niet in behandeling worden genomen. Onderdelen voor ombouw kunnen tegen vooruitbetaling gekocht worden. Ons adres is: Revell GmbH & Co. KG, Abteilung X, Henschelstrasse 20-30, 32257 Bünde, Duitsland. Deze directe service geldt alleen voor de volgende landen: Duitsland, Benelux, Oostenrijk, Frankrijk, Groot-Brittannië. Klachten afkomstig uit overige landen worden via de eventuele lokale vertegenwoordigers van Revell afgewikkeld. Wij verzoeken U contact op te nemen met uw winkelier.*

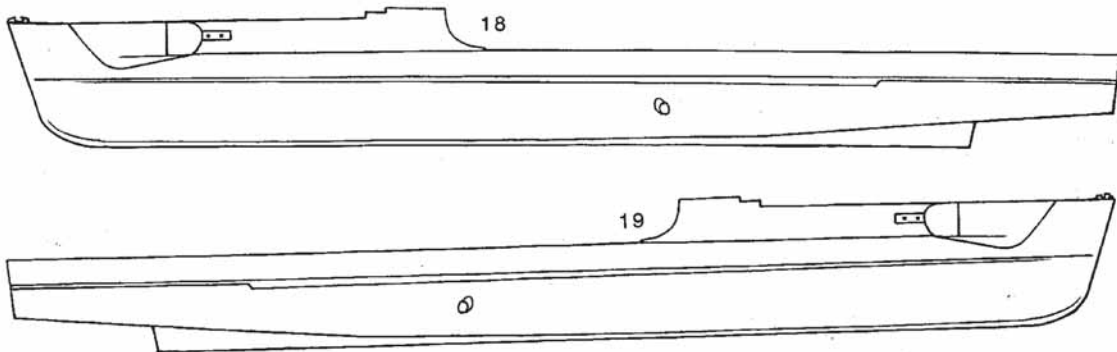
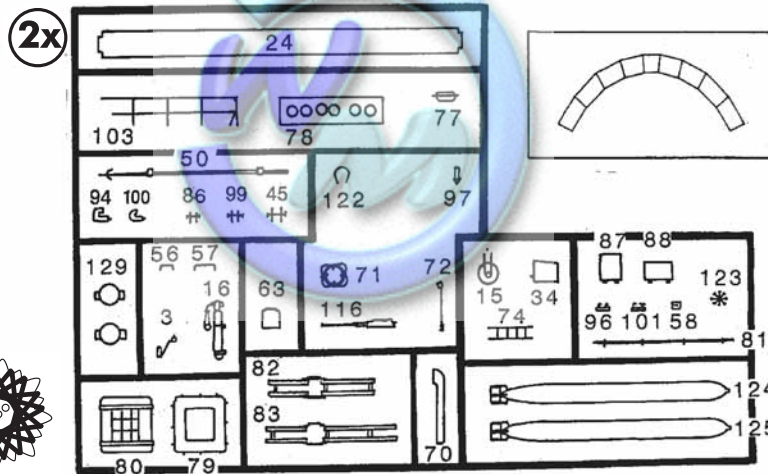
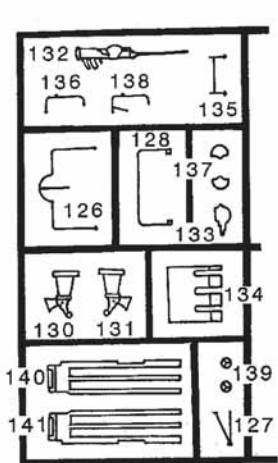
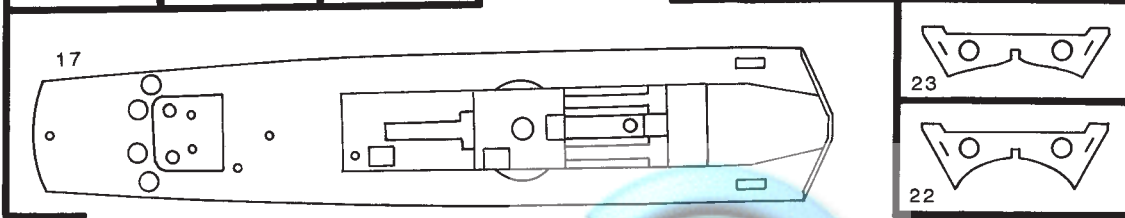
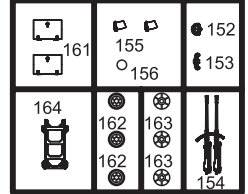
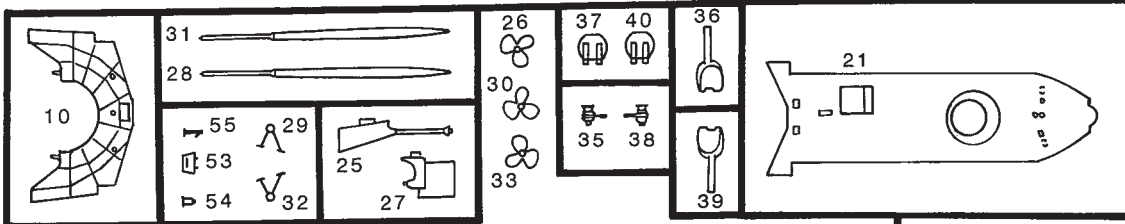
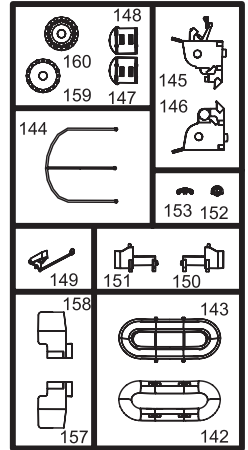
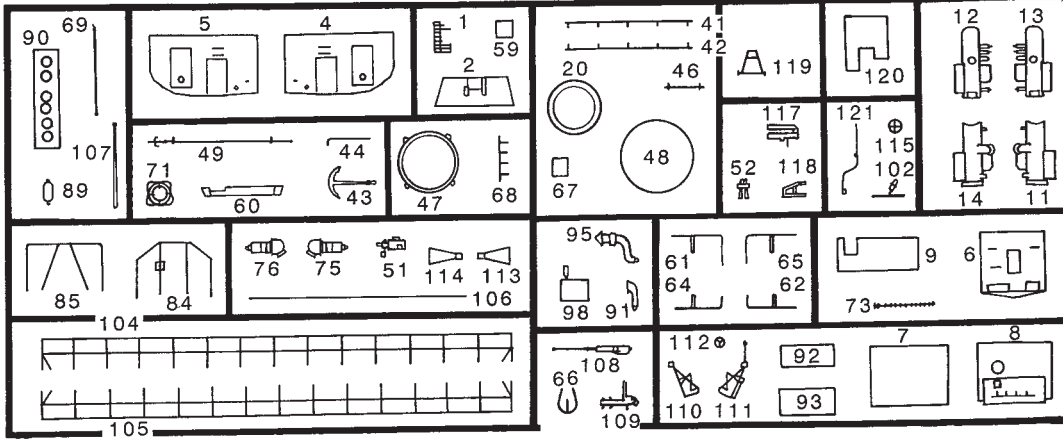

**! Versions ?**  
**65 → 74**

05002

# ! Versions ? 65 → 74!

1 

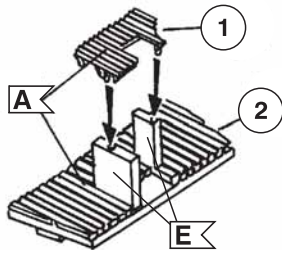

3 

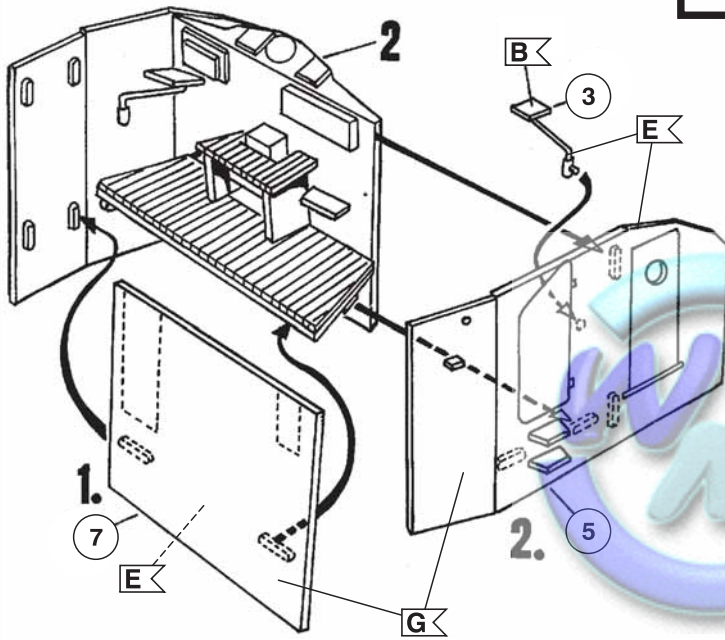

2  

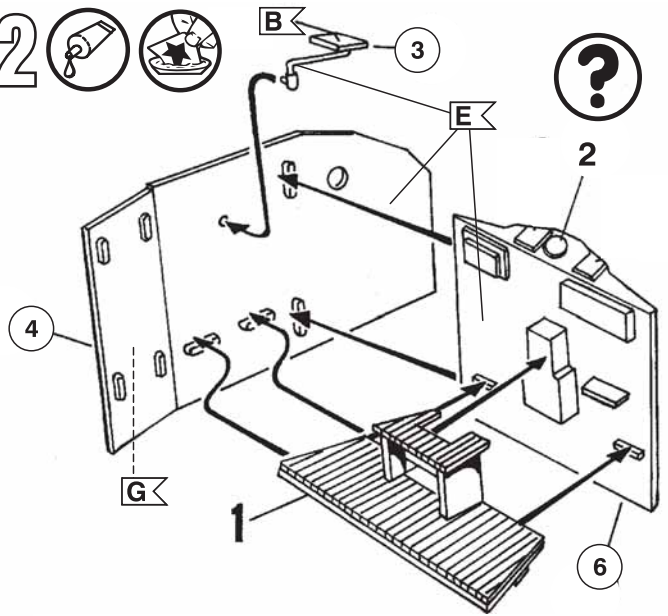

4 

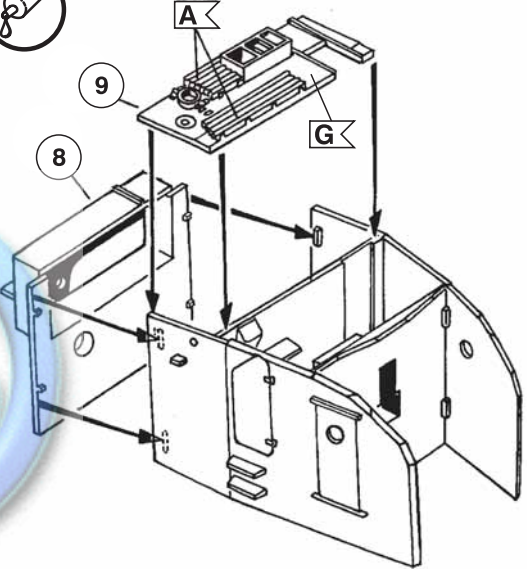

5 

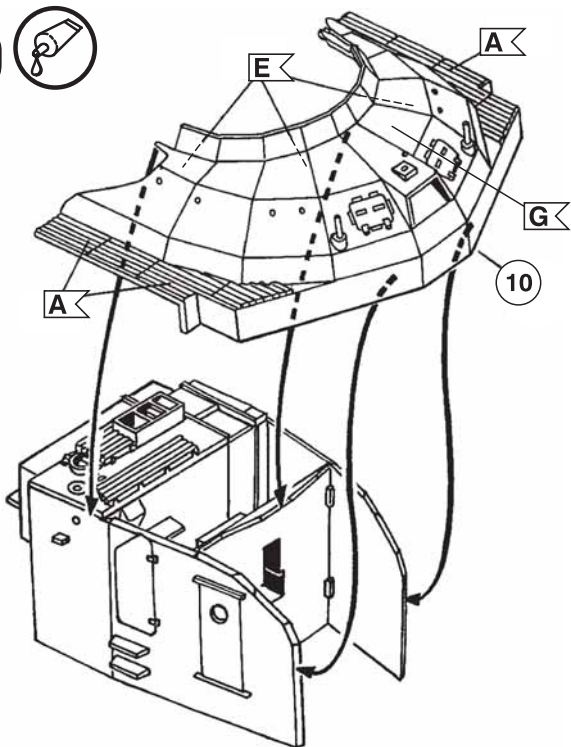

6 

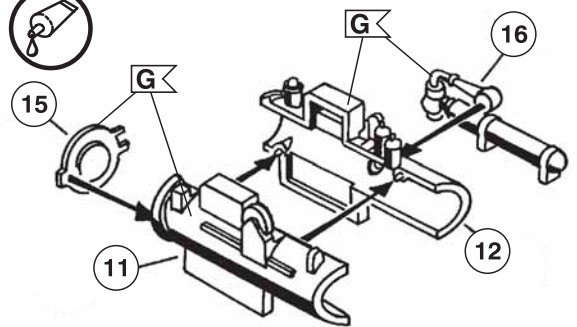

7 

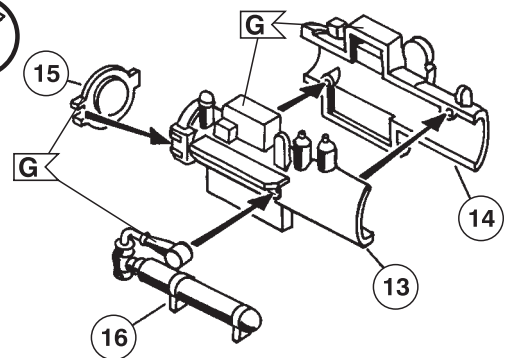

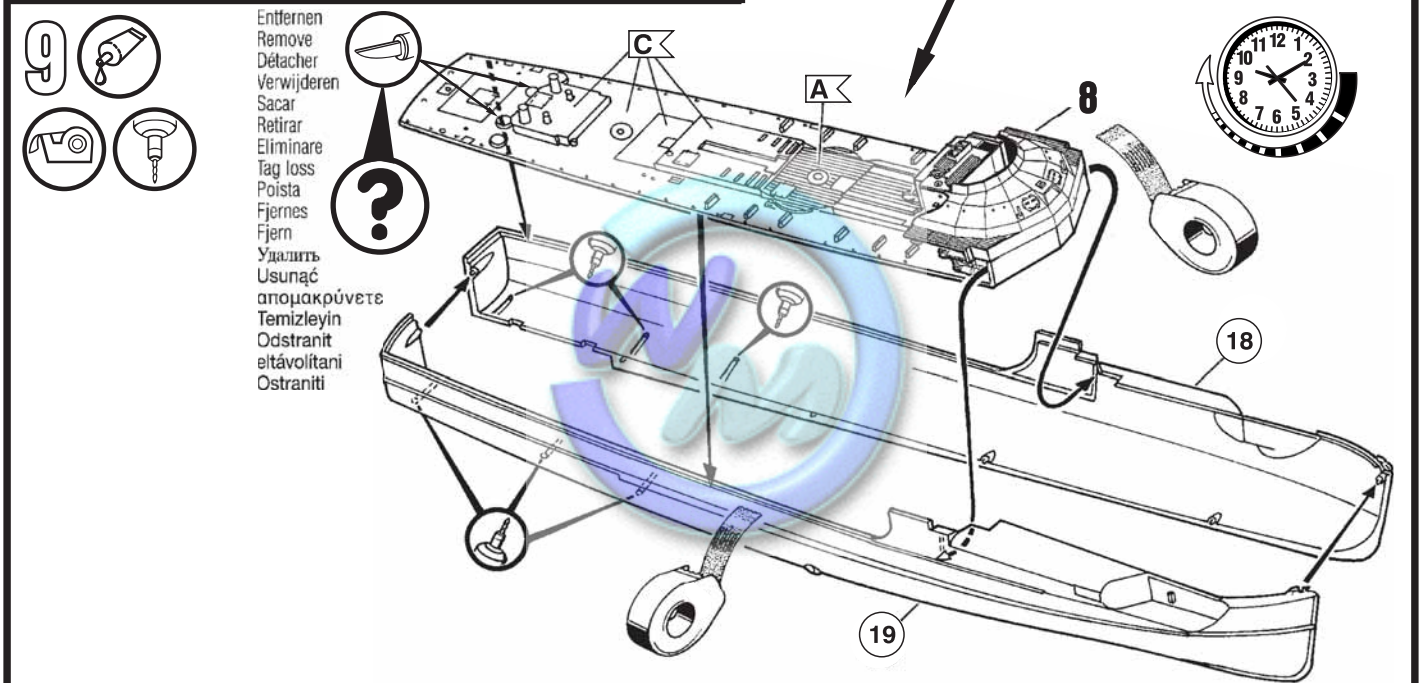
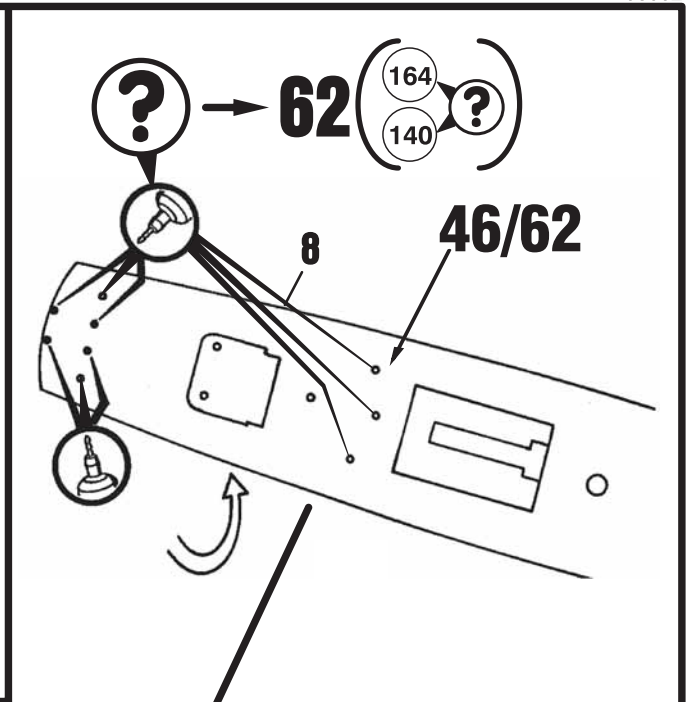
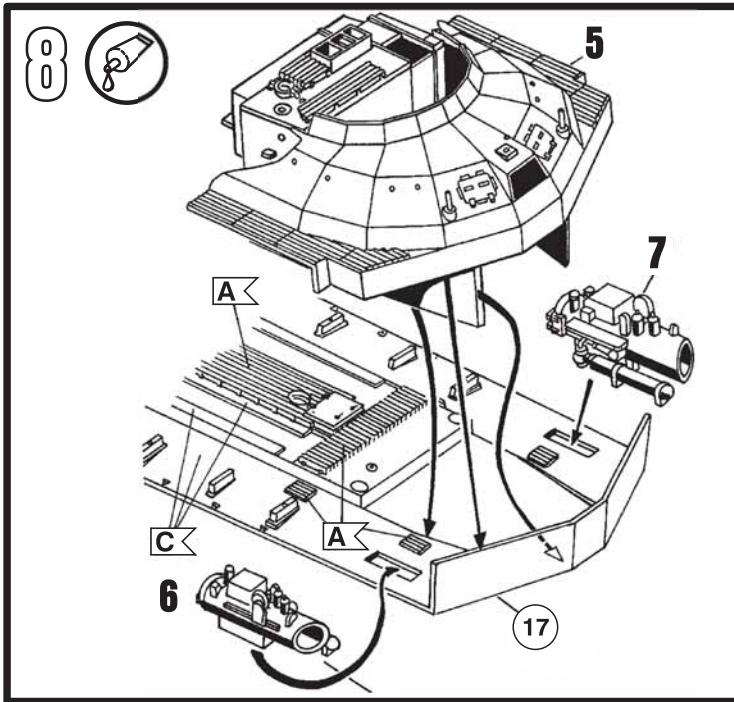

Entfernen  
Remove  
Détacher  
Verwijderen  
Sacar  
Retirar  
Eliminare  
Tag loss  
Poista  
Fjern  
Fjern  
Удалить  
Usunąć  
απομακρύνετε  
Temizleyin  
Odstranit  
eltávolítani  
Ostraniti

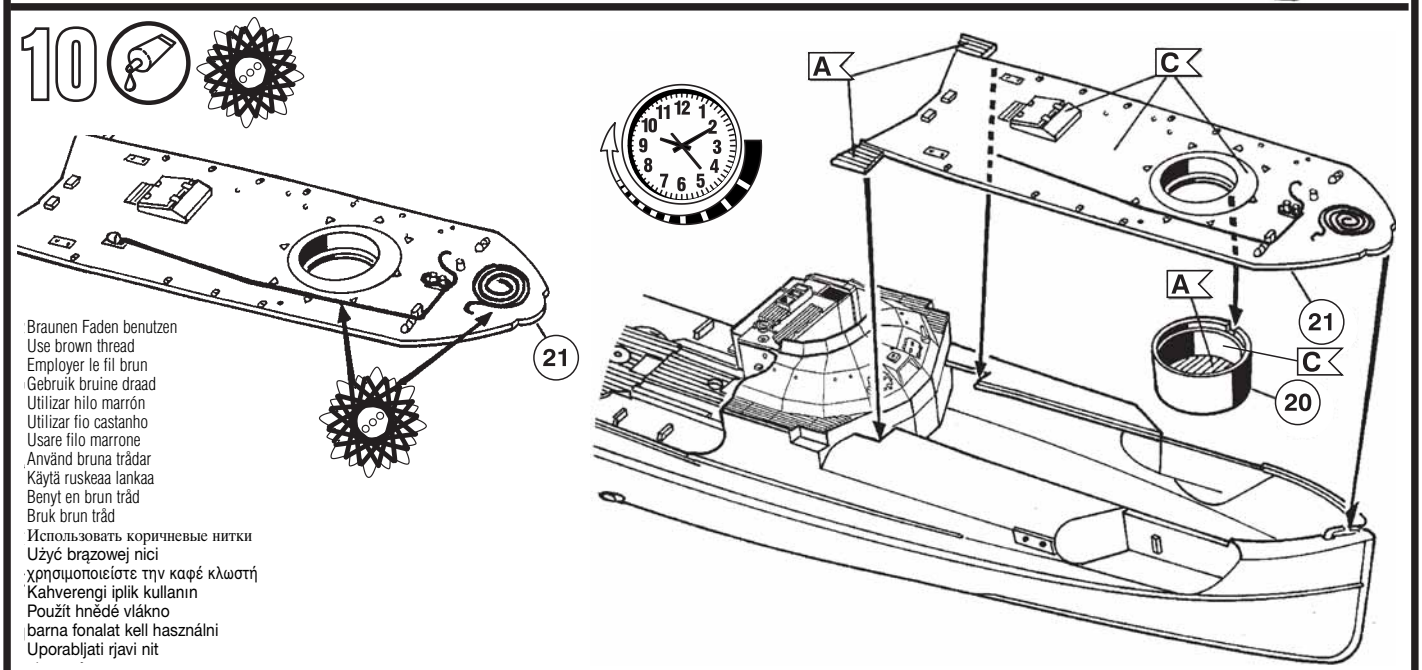

Braunen Faden benutzen  
Use brown thread  
Employer le fil brun  
Gebruik bruine draad  
Utilizar hilo marrón  
Utilizar fio castanho  
Usare filo marrone  
Använd bruna trådar  
Käytä ruskeaa lankaa  
Benyt en brun tråd  
Bruk brun tråd  
Использовать коричневые нитки  
Użyć brązowej nici  
χρησιμοποιήστε την καφέ κλωστή  
Kahverengi iplik kullanın  
Použit hnědé vlákno  
barna fonalat kell használni  
Uporabljati rjavi nit

05002

11    65 → 74

12 

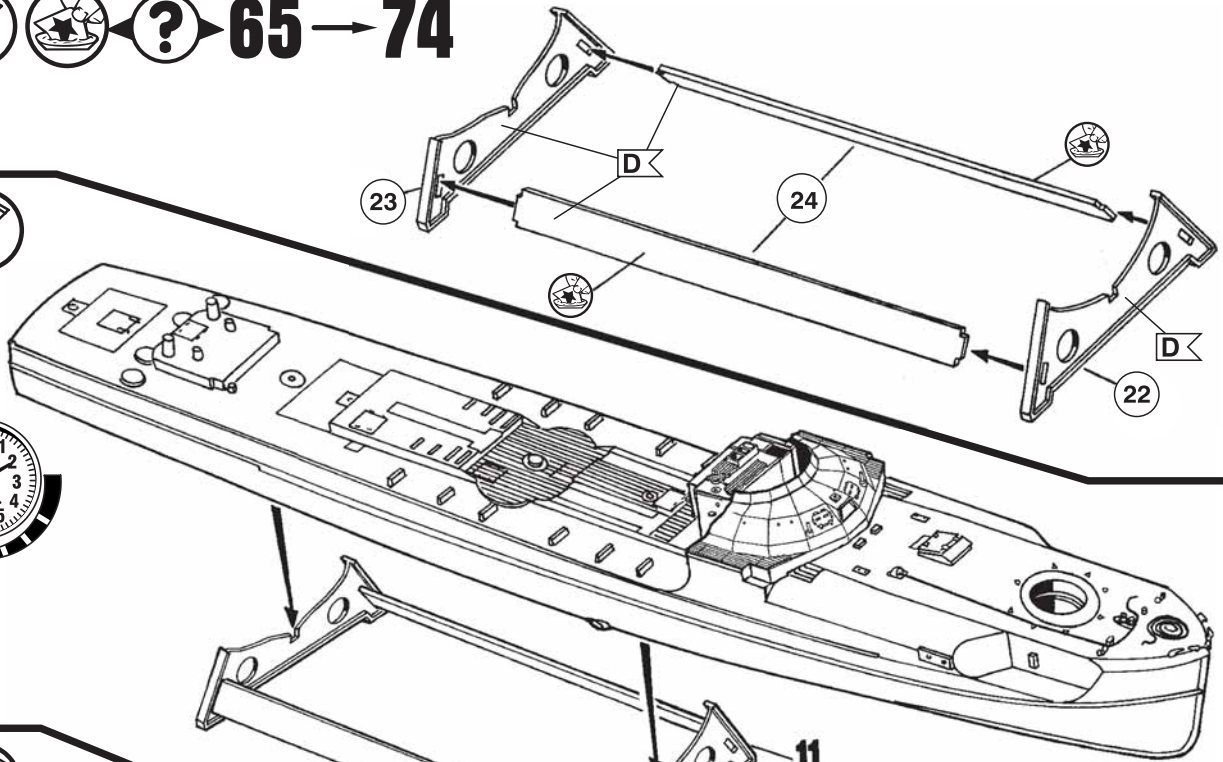

13 

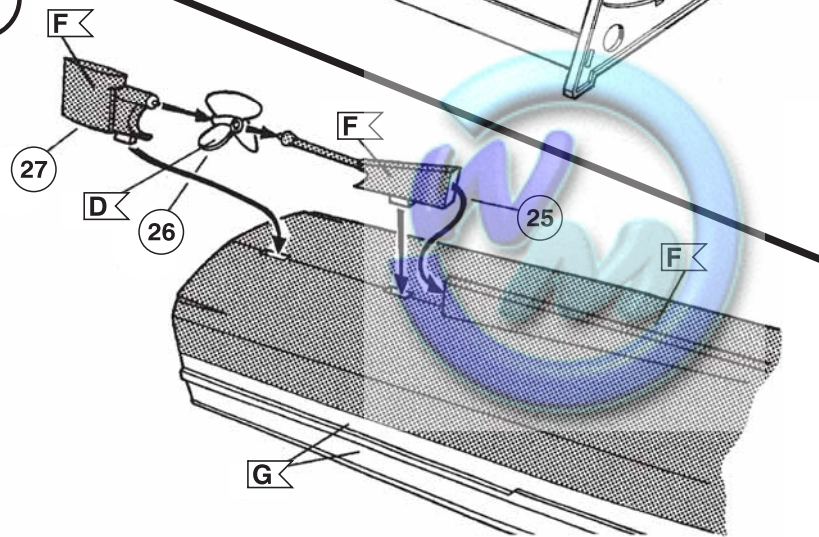

14 

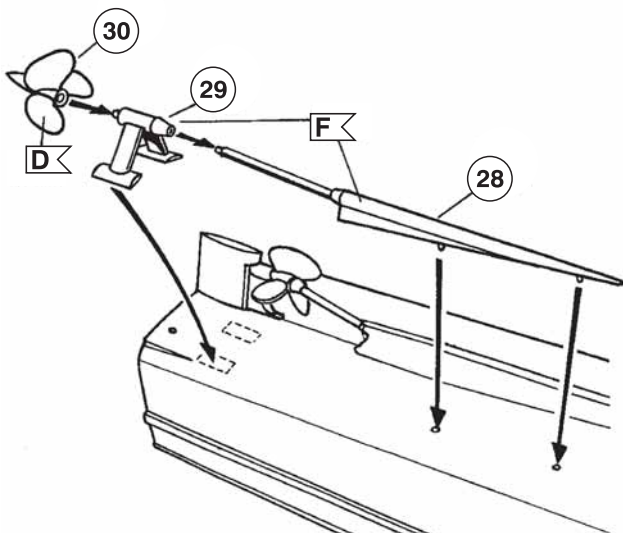

15 

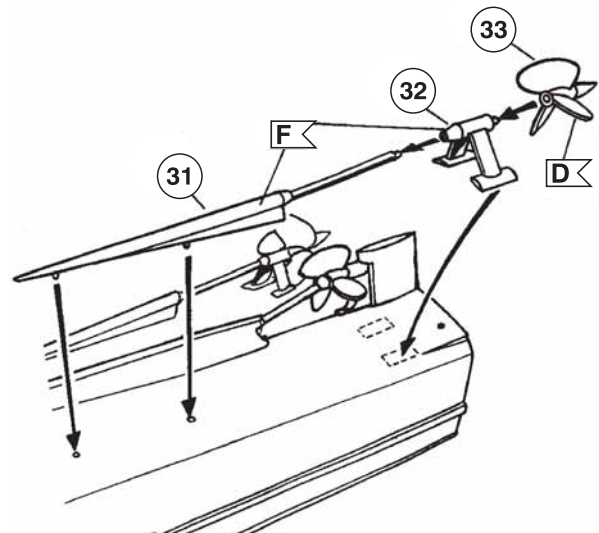

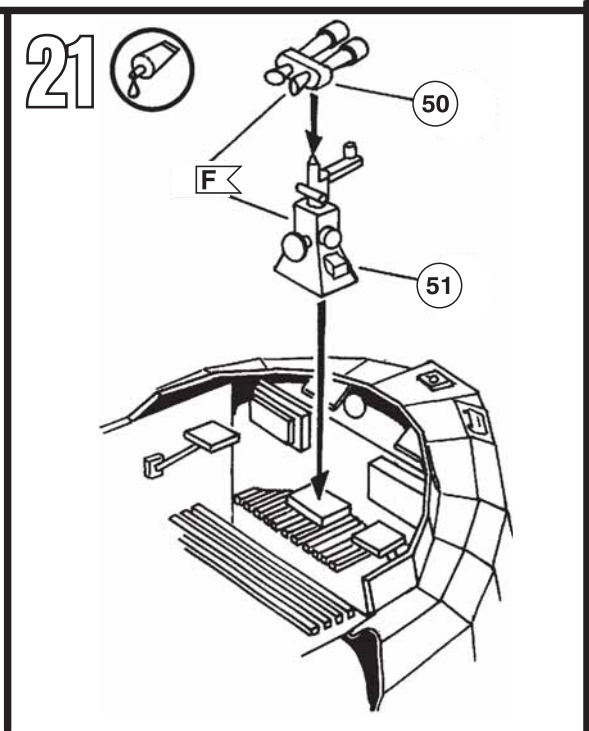
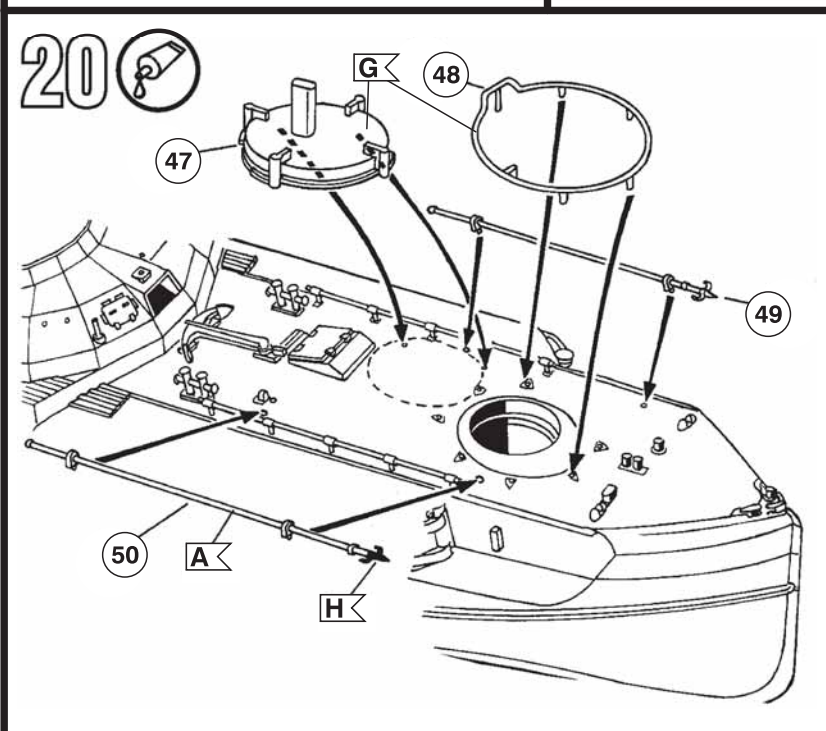
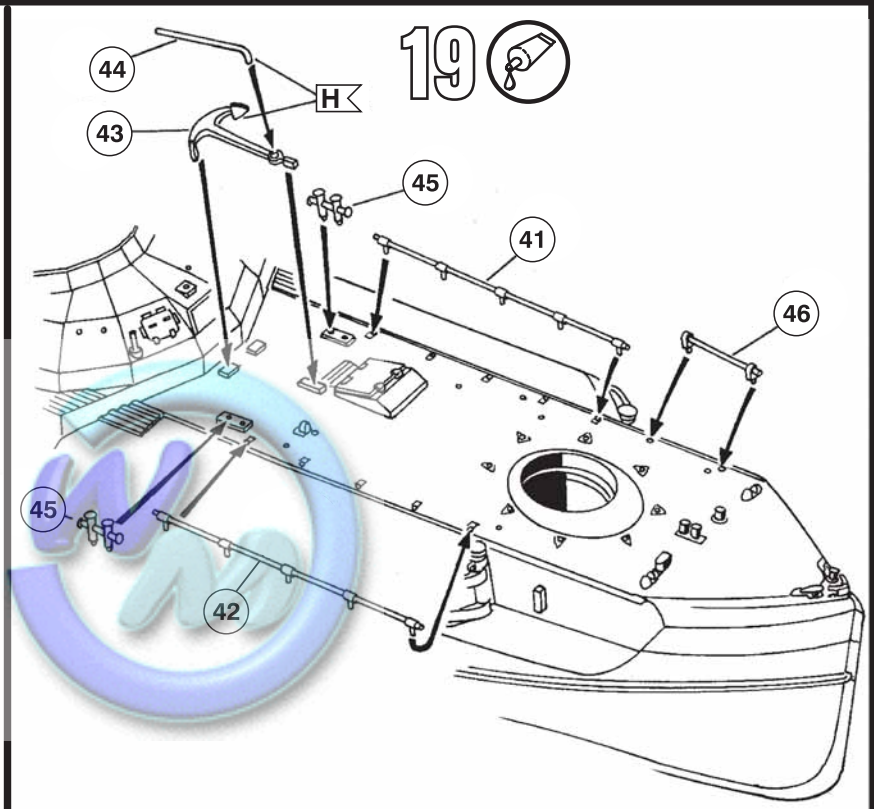
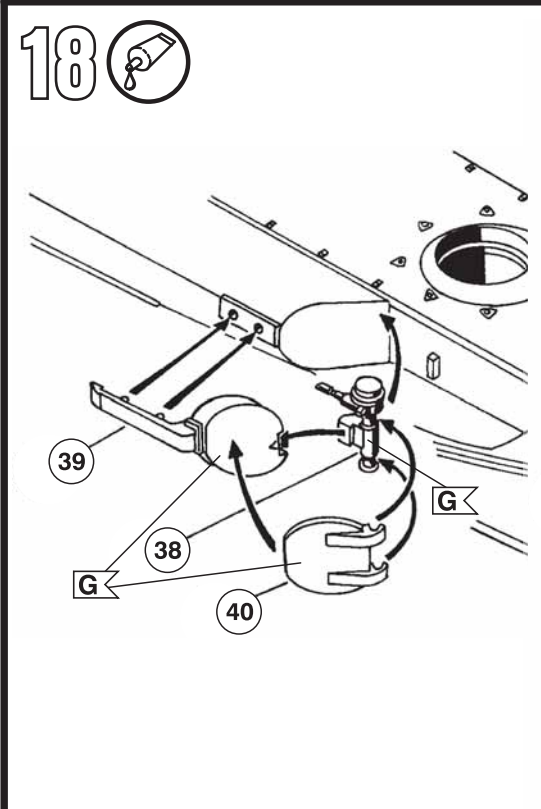
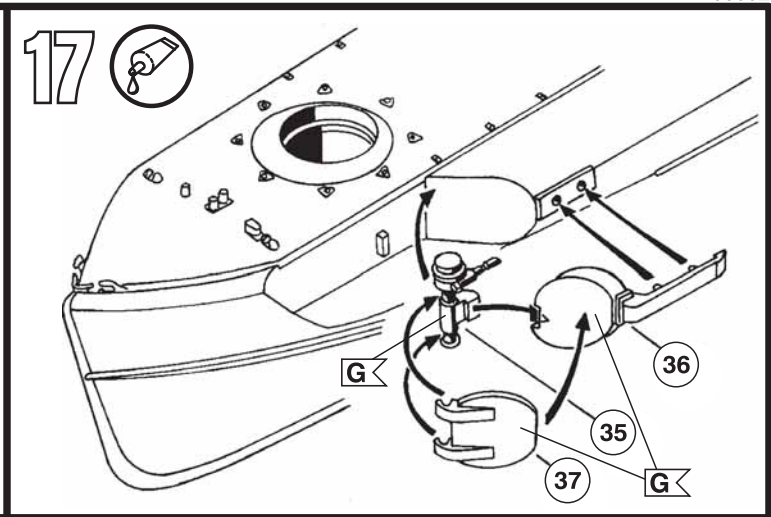
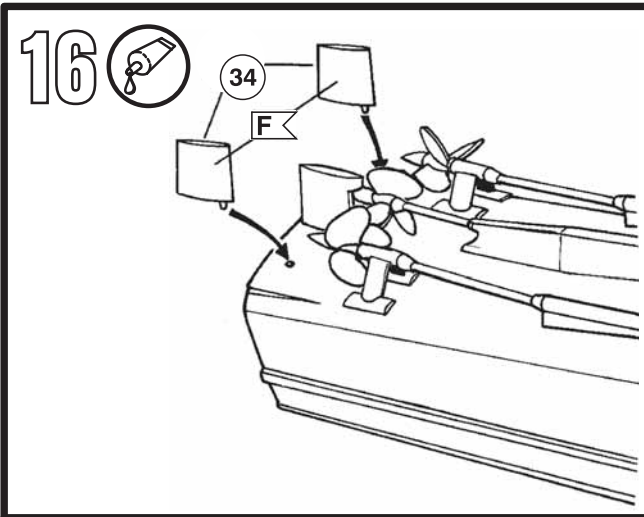

05002

22 

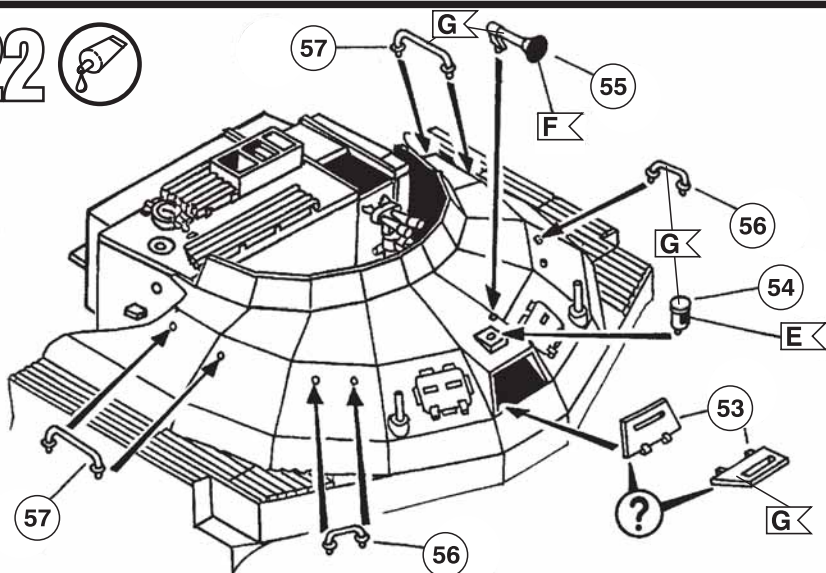

23 

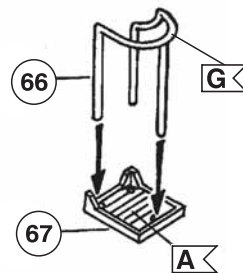

24 

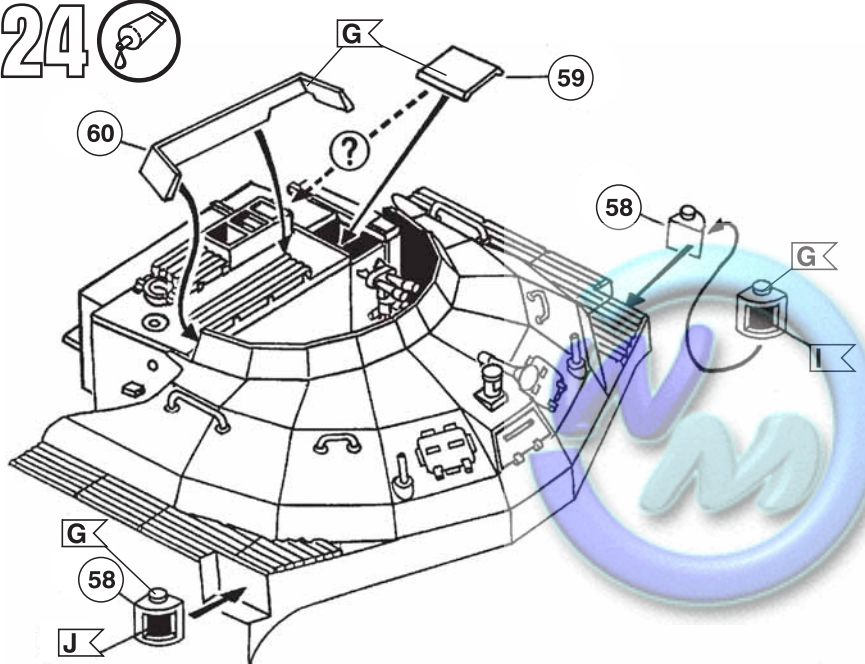

25 

3x

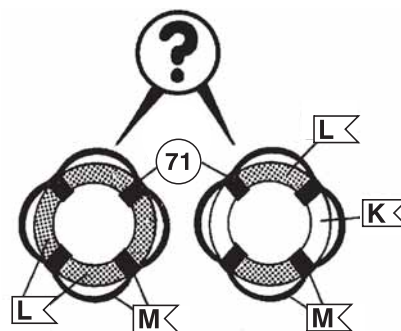

26 

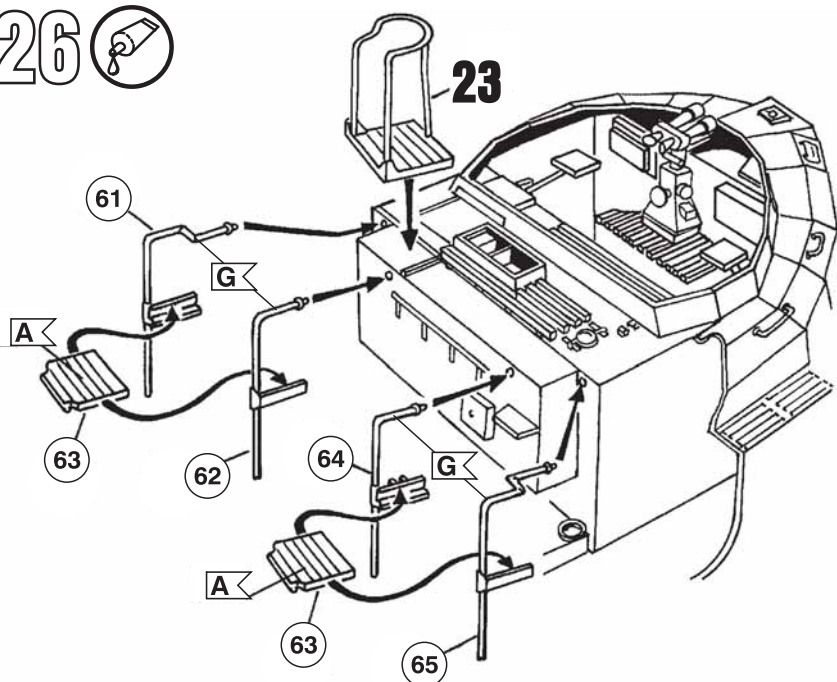

27 

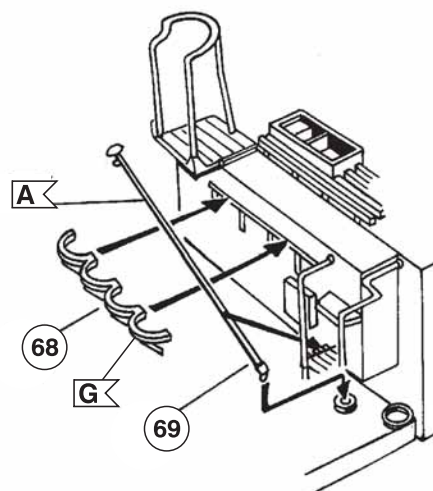

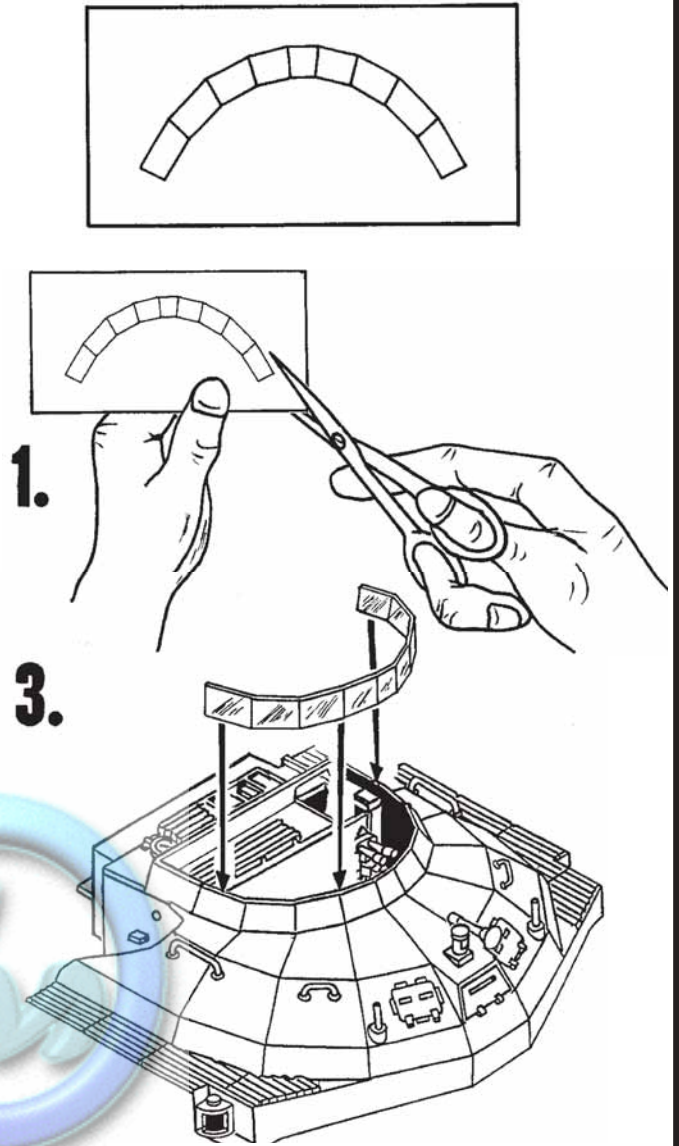
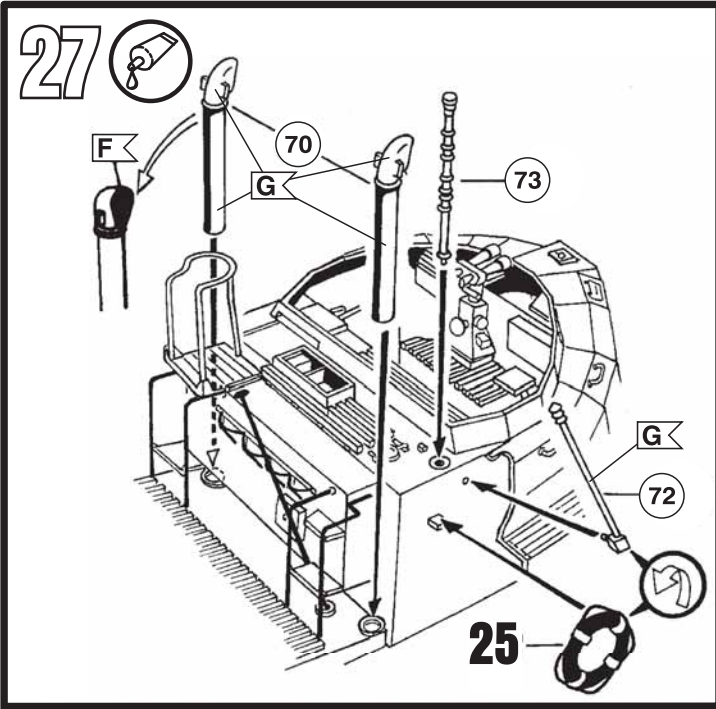

28 2.

a



b

Braunen Faden benutzen  
 Use brown thread  
 Employer le fil brun  
 Gebruik bruine draad  
 Utilizar hilo marrón  
 Utilizar fio castanho  
 Usare filo marrone  
 Använd bruna trådar  
 Käytä ruskeaa lankaa  
 Benyt en brun tråd  
 Bruk brun tråd  
 Использовать коричневые нитки  
 Użyć brązowej nici  
 χρησιμοποιείστε την καφέ κλωστή  
 Kahverengi iplik kullanın  
 Použit hnědé vlákno  
 barna fonalat kell használni  
 Uporabljati rjavi nit

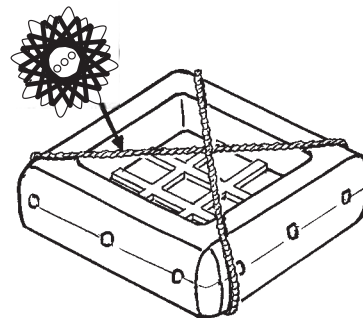
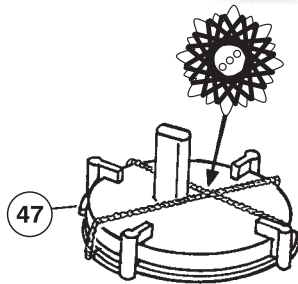

→ 32  
 → 53

29

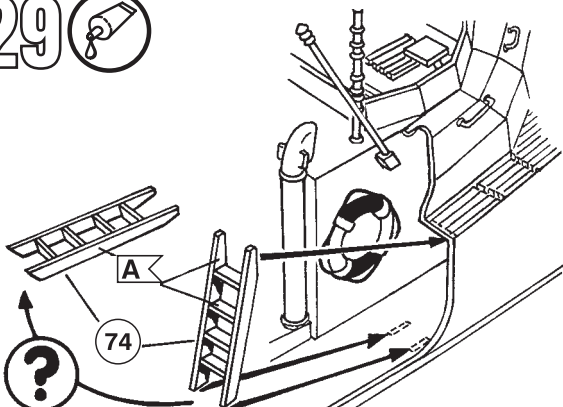

30

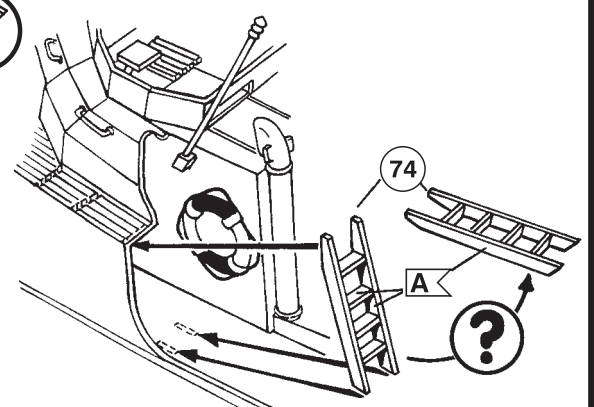

05002

31

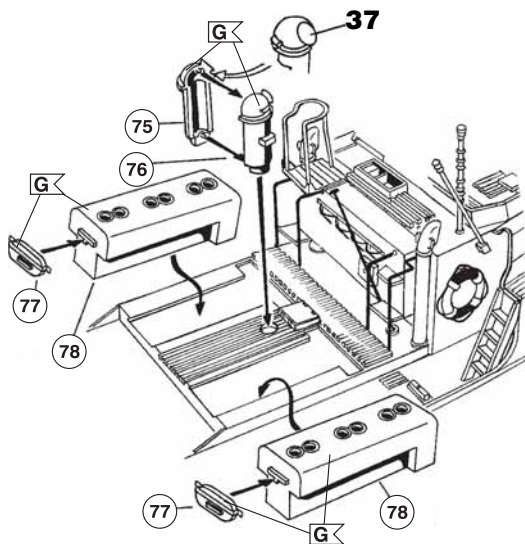

32

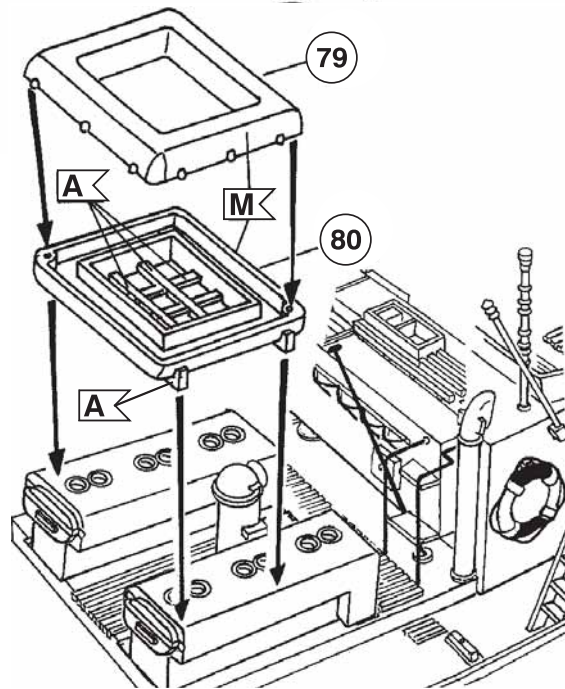

33

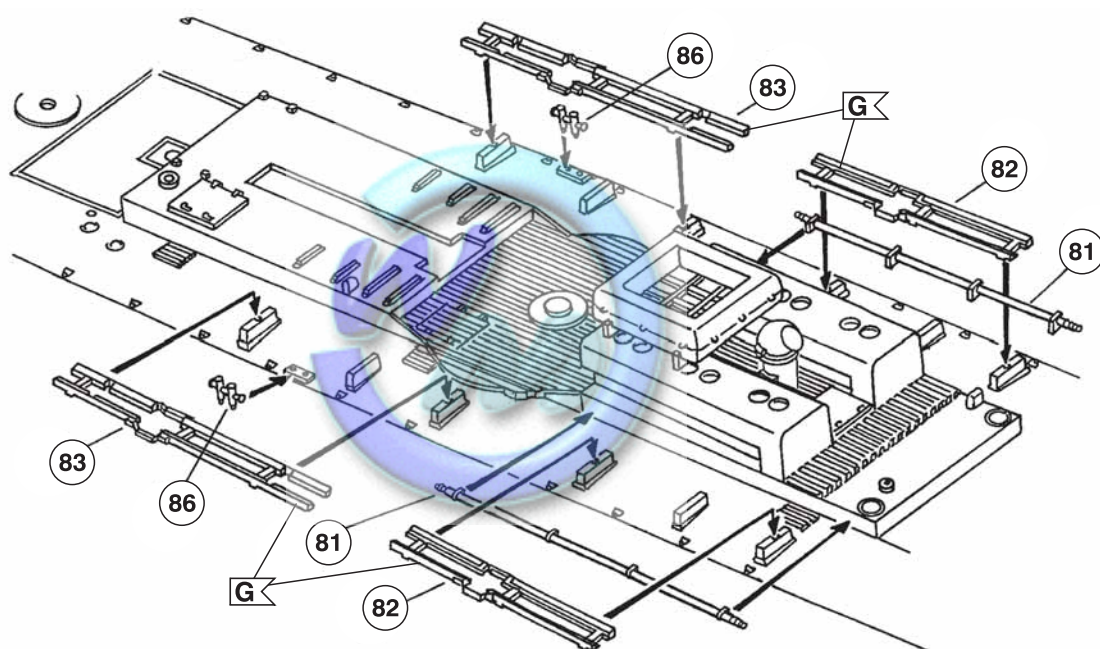

34

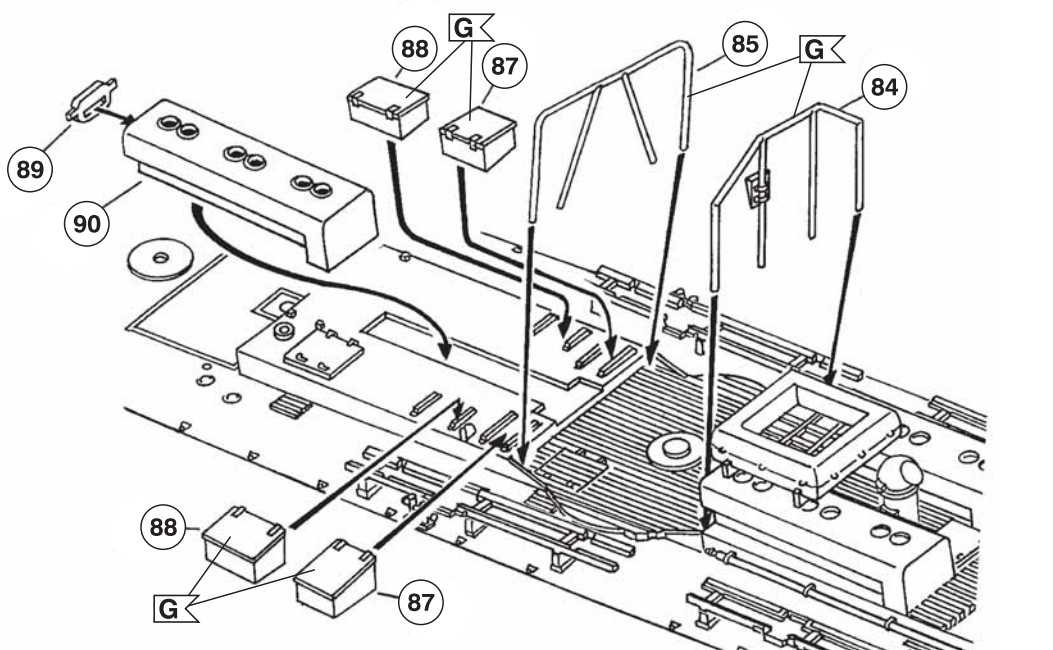

# 35

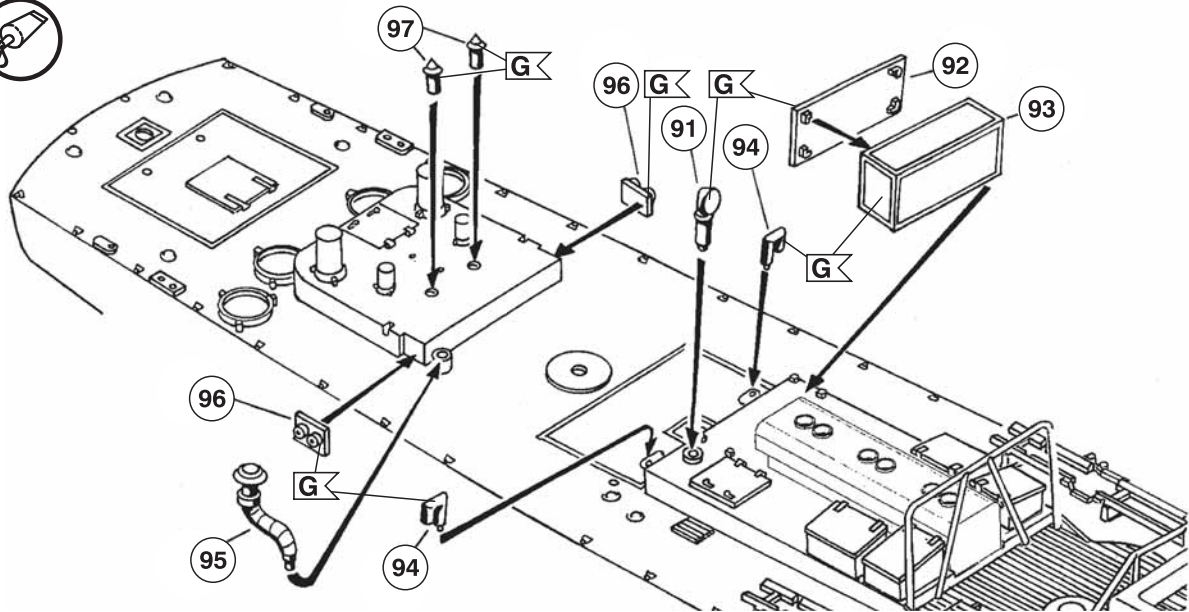

# 36

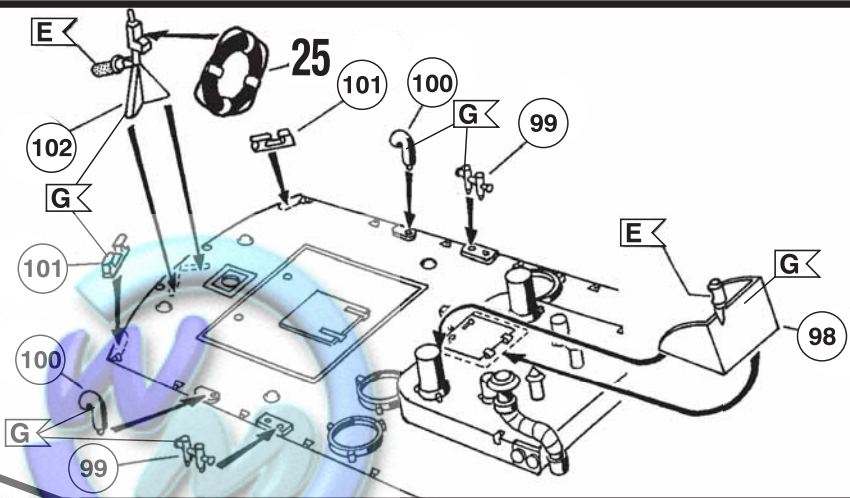

# 37

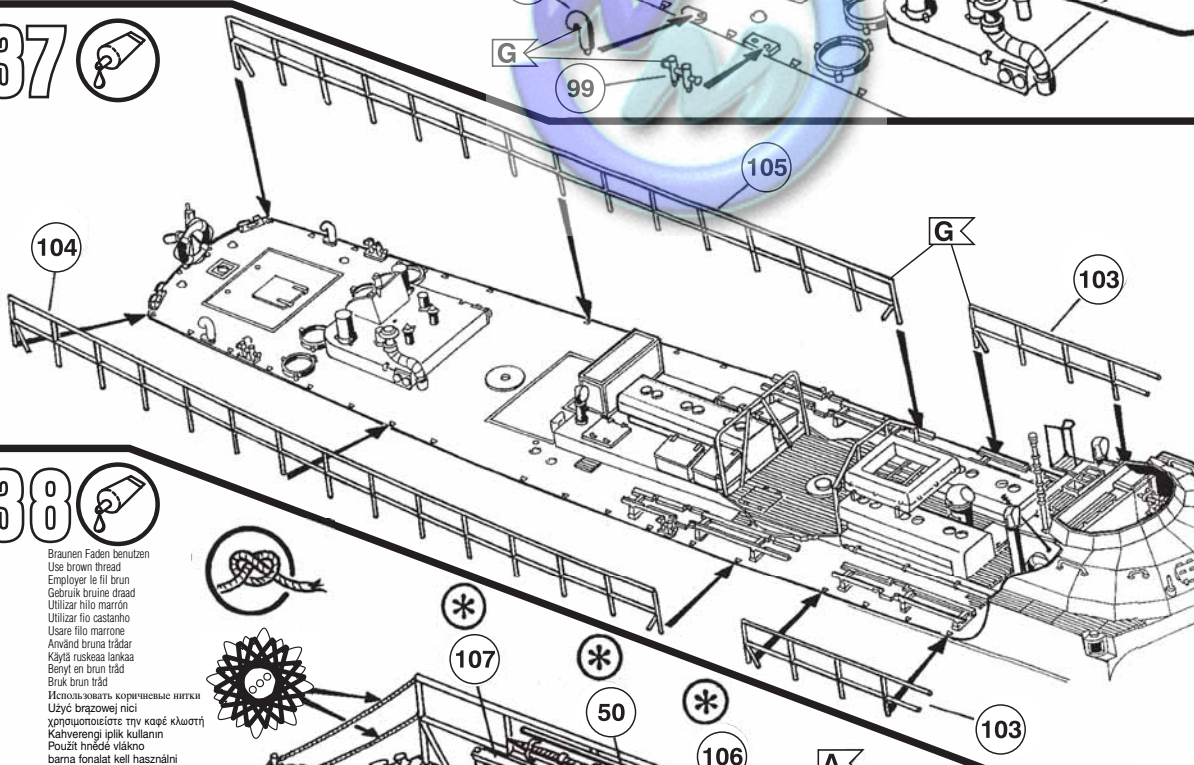

# 38

Braunen Faden benutzen  
 Use brown thread  
 Employer le fil brun  
 Gebruik bruine draad  
 Utilizar hilo marrón  
 Utilizar fio castanho  
 Usare filo marone  
 Aivand brunu trãder  
 Käytä ruskeaa lankaa  
 Benyt en brun tråd  
 Bruk brun tråd  
 Исползовать коричневые нитки  
 Użyć brązowej nici  
 χρησιμοποισετε την καφέ κλωστή  
 Kahverengi ipik kullanin  
 Použit hnědé vlákno  
 barna fonalát kell használni  
 Uporabljati rjavi nit



Anknoten und Kleben  
 Tie and Glue  
 Vastlaggen en Lijmen  
 Atar y Engonar  
 Amudar e Colar  
 Amoldare e Incollare  
 Knyf fast och Limmas  
 Solim ja Limmaa  
 Bindes fast og Klæbning  
 Knyf og Lim  
 Связать узлом и Клеить  
 Przywiązać oraz Przykleić  
 κολληθείτε και κόλλημα  
 Dügünleýin ve Yapıştırma  
 Naúžit a Lepení  
 megcsomózni és ragasztani  
 Zavezati in Lepiti

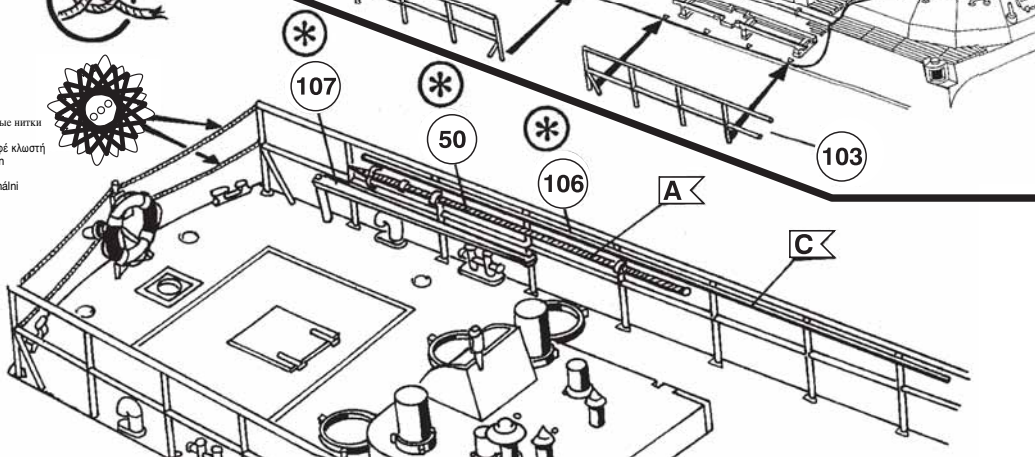

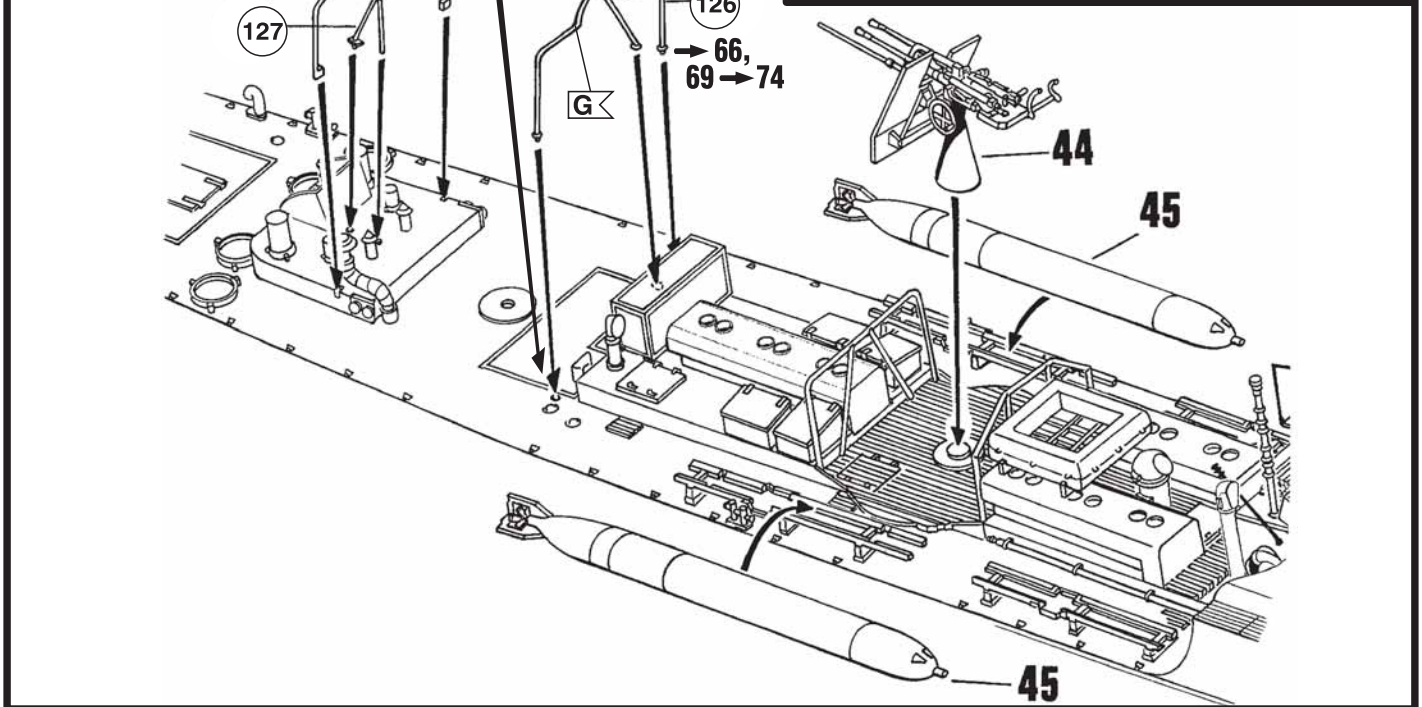
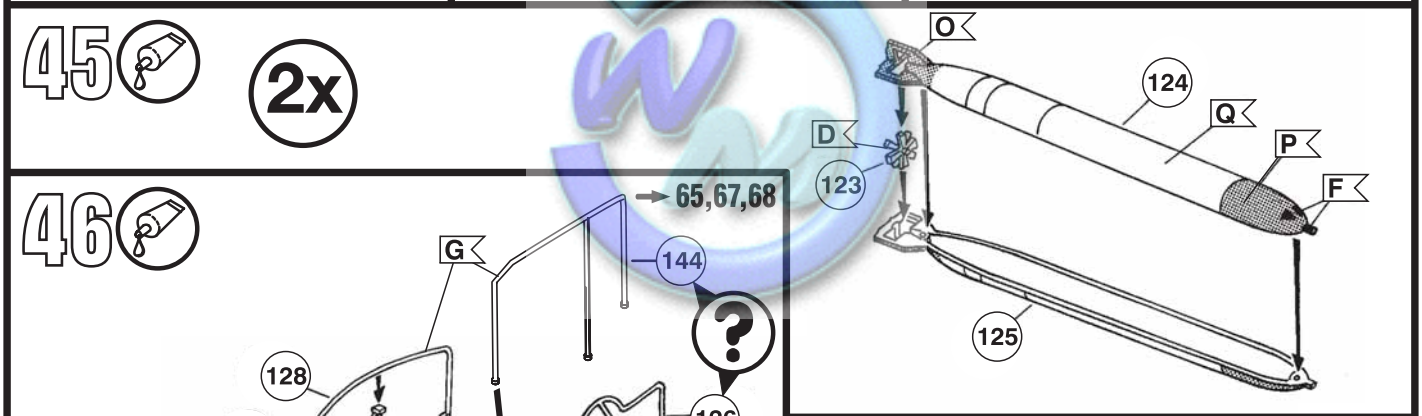
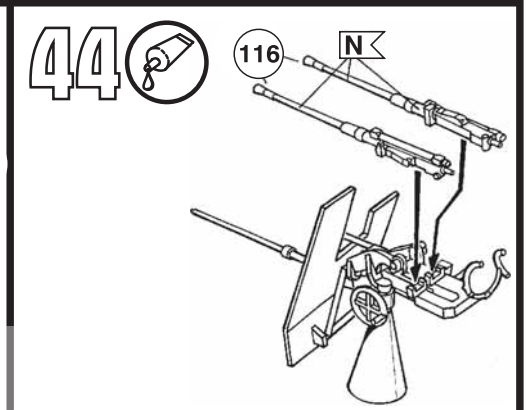
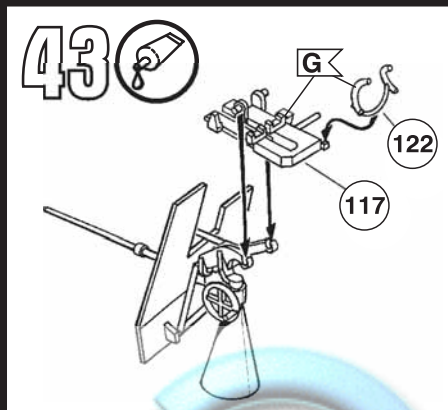
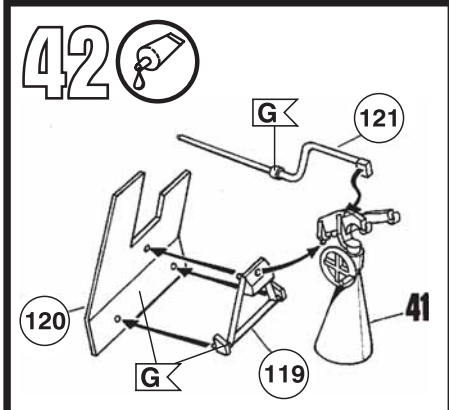
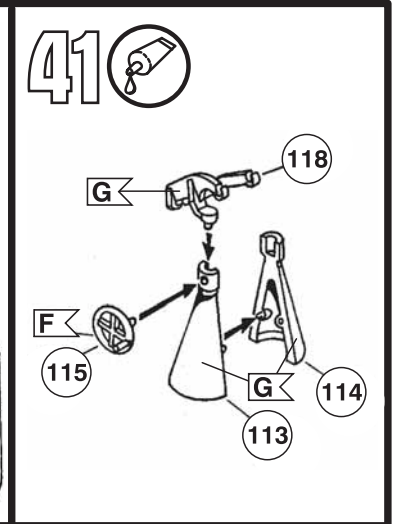
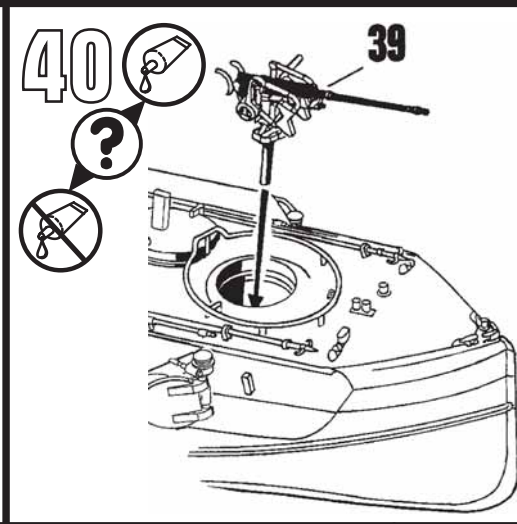
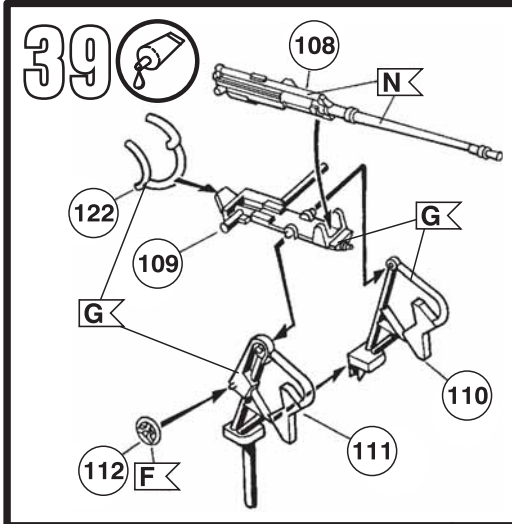

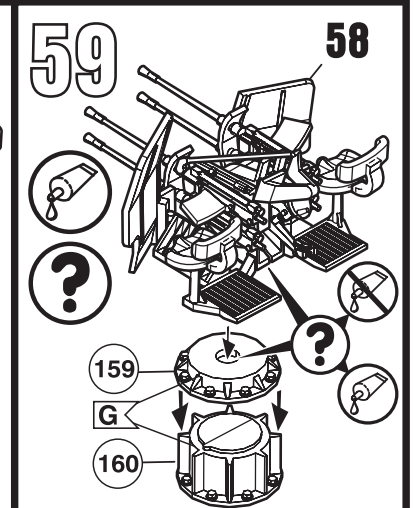
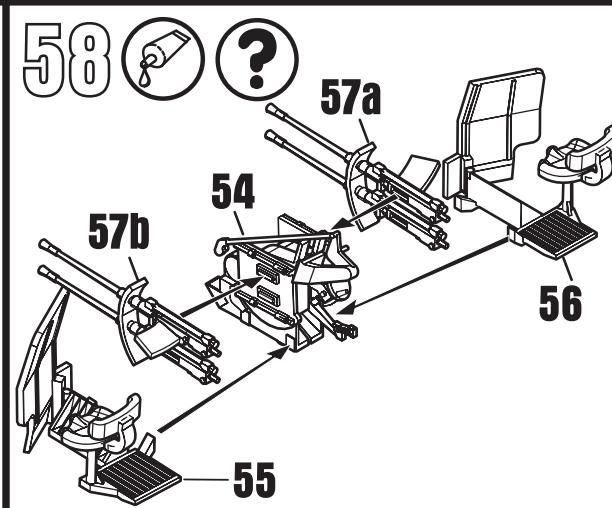
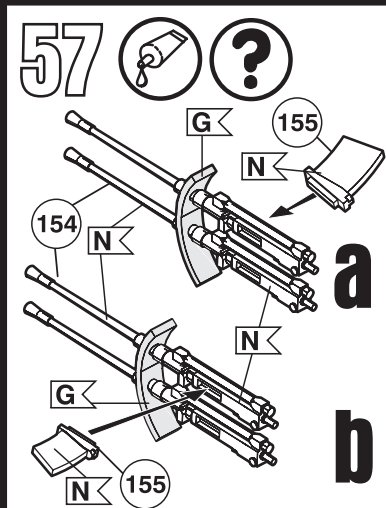
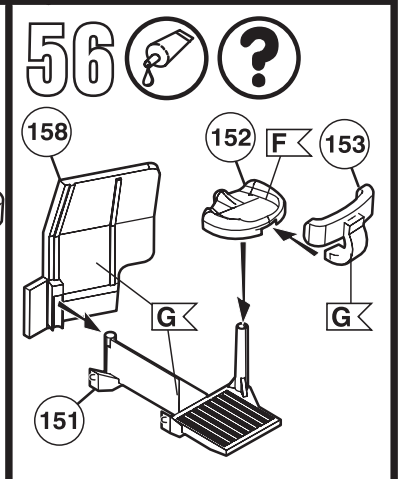
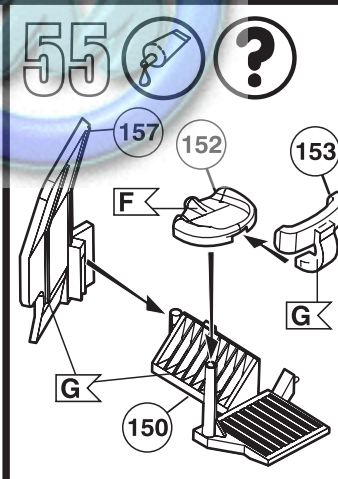
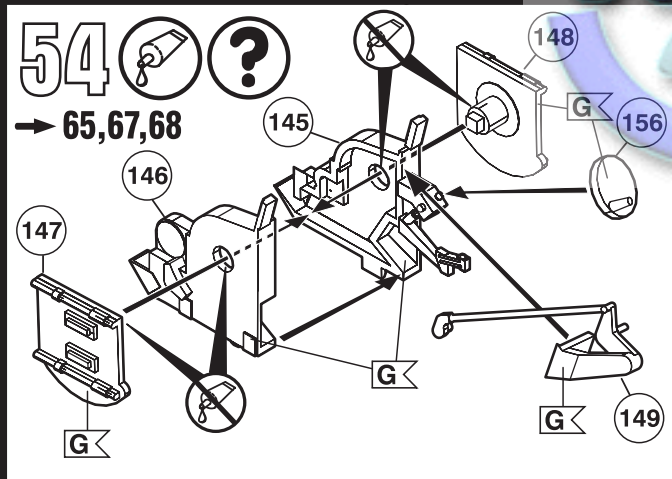
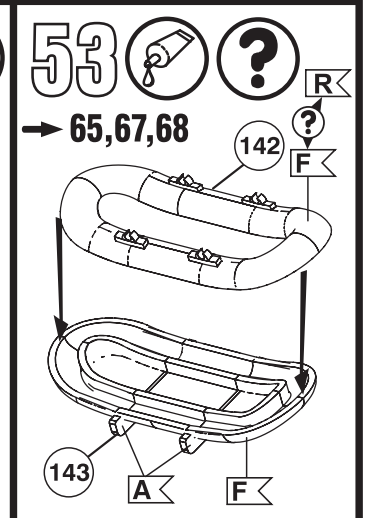
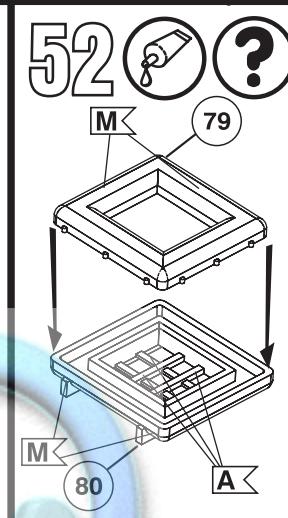
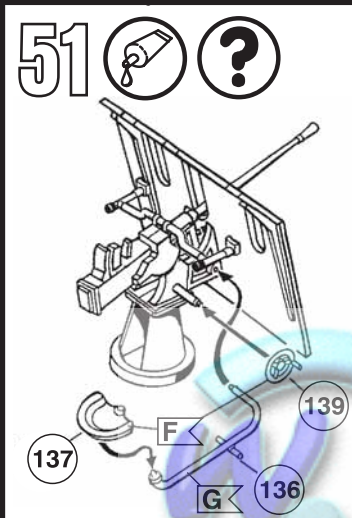
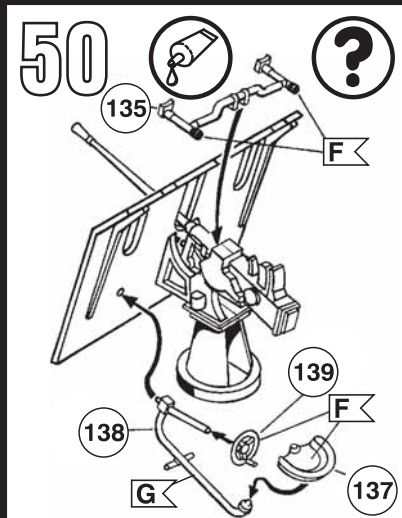
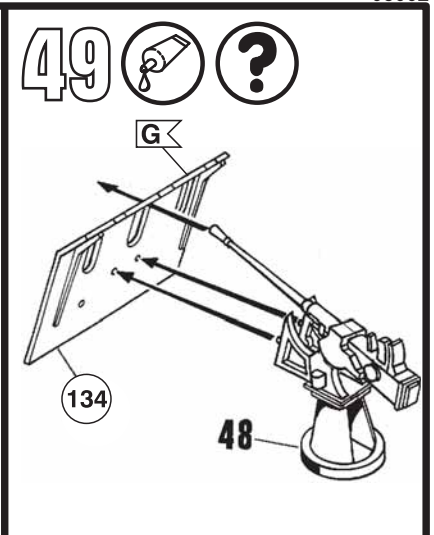
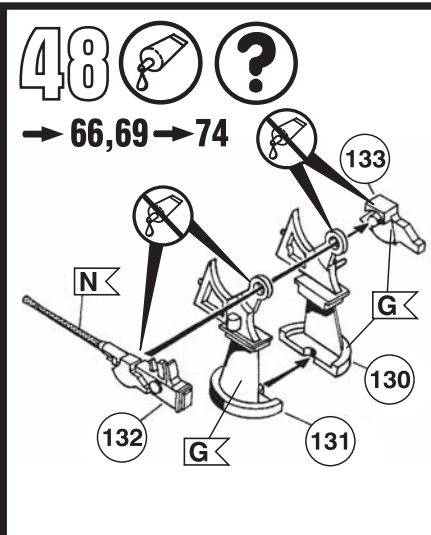
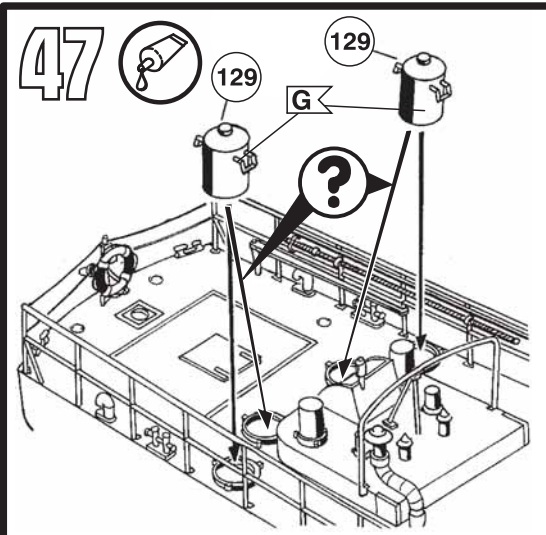

60  6x

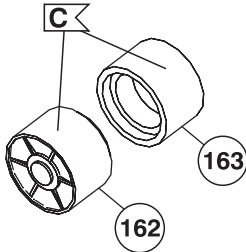

62 

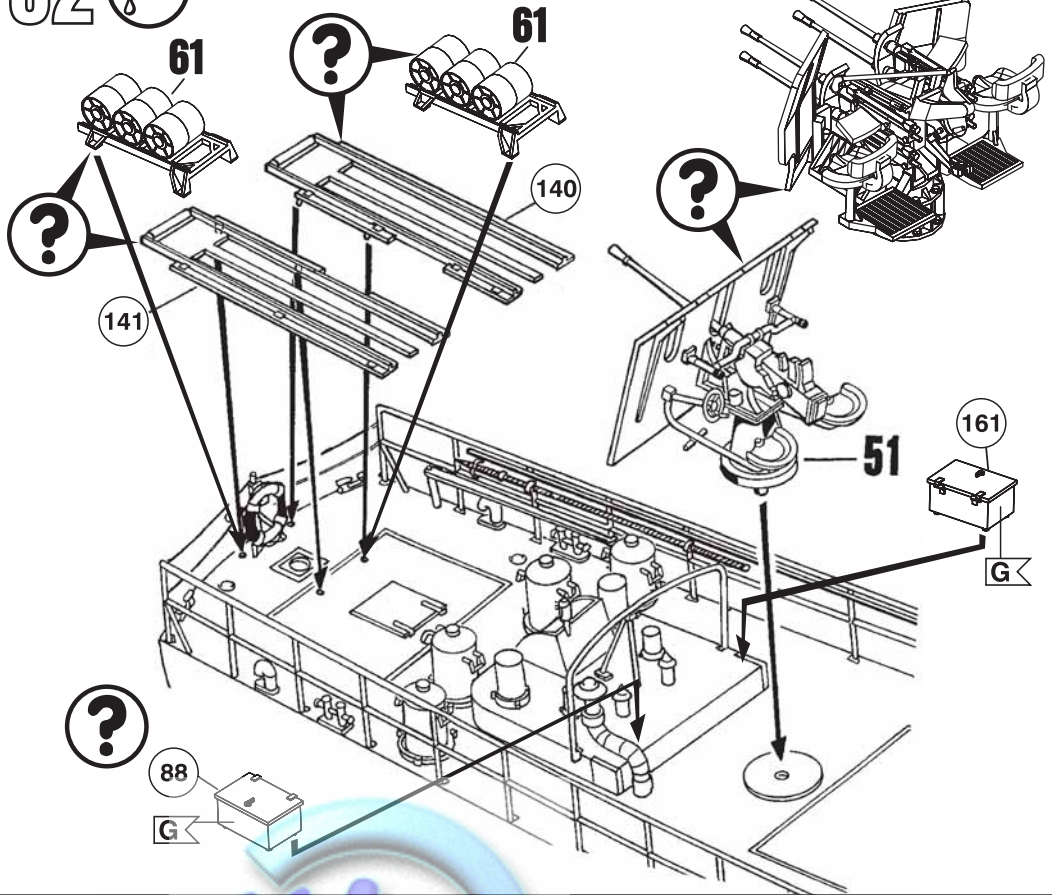

61  2x

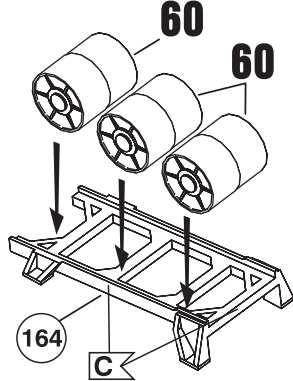

63 

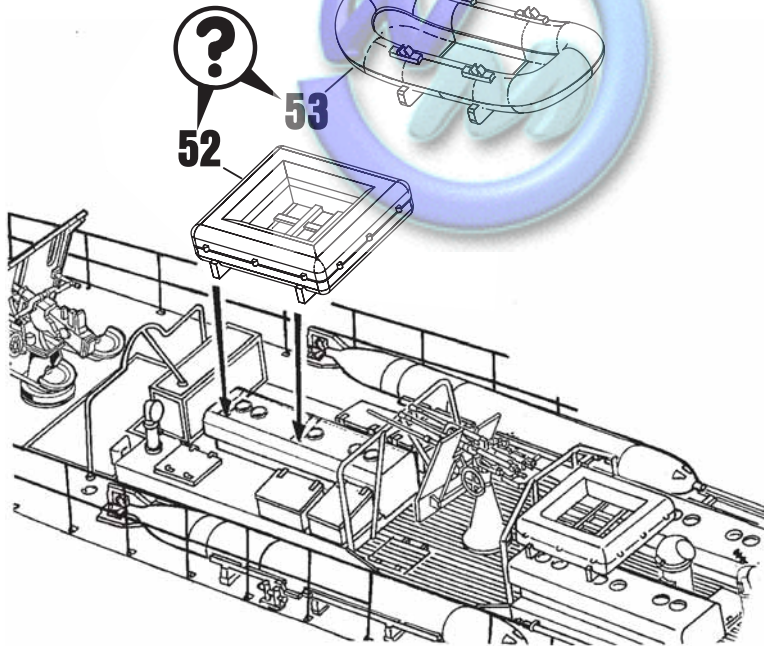

64

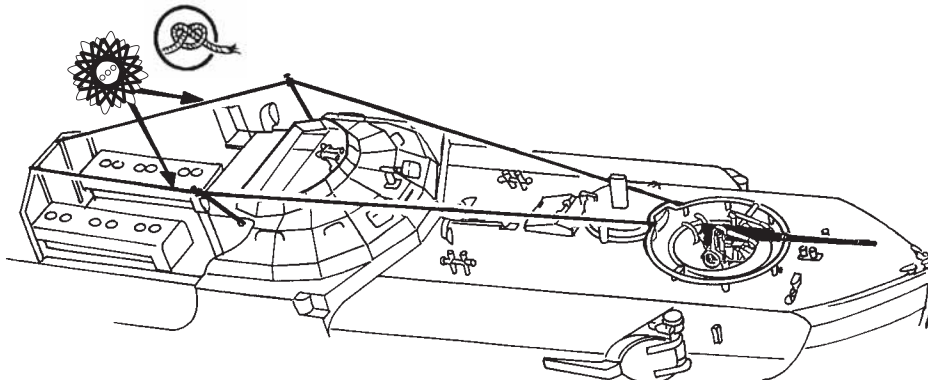

Braunen Faden benutzen  
 Use brown thread  
 Employer le fil brun  
 Gebruik bruine draad  
 Utilizar hilo marrón  
 Utilizar fio castanho  
 Usare filo marrone  
 Använd brun trådar  
 Käytä ruskeaa lankaa  
 Benyt en brun tråd  
 Bruk brun tråd  
 Исползовать коричневые нитки  
 Użyć brązowej nici  
 χρησιμοποιήστε την καφέ κλωστή  
 Kahverengi iplik kullanın  
 Použit hnedé vlákno  
 barna fonalat kell használni  
 Uporabljati rjavi nit

Anknoten und Kleben  
 Tie and Glue  
 Attacher et Coller  
 Vastknopen en Lijmen  
 Atar y Engomar  
 Anudar e Colar  
 Anodare e Incollare  
 Knytt fast och Limmas  
 Solmi ja Limmas  
 Bindas fast og Klæbning  
 Knytt og Lim  
 Связати узлом И Клеити  
 Przywiązać oraz Przykleić  
 κομποδεύστε και κόλλημα  
 Bağumleyin ve Yapıştırma  
 Nauziti a Lepeni  
 i megcsomózni és ragasztani  
 Zavezati in Lepiti



S 302, 8th flotilla, based in Egersund/Norway, May 1945



German Fast Attack Craft S 100-type with "Flakvierling" alternative 3

German Fast Attack Craft S 100-type with "Flakvierling" alternative 3

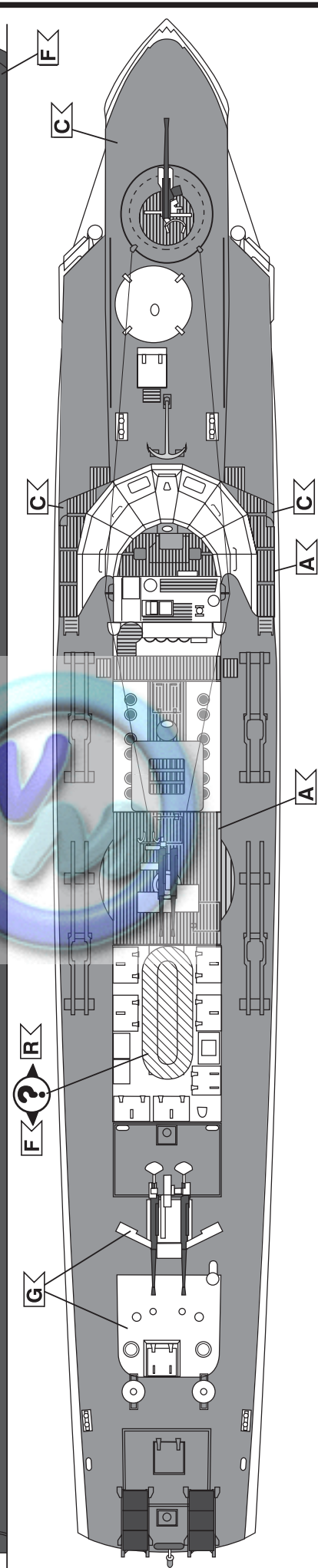
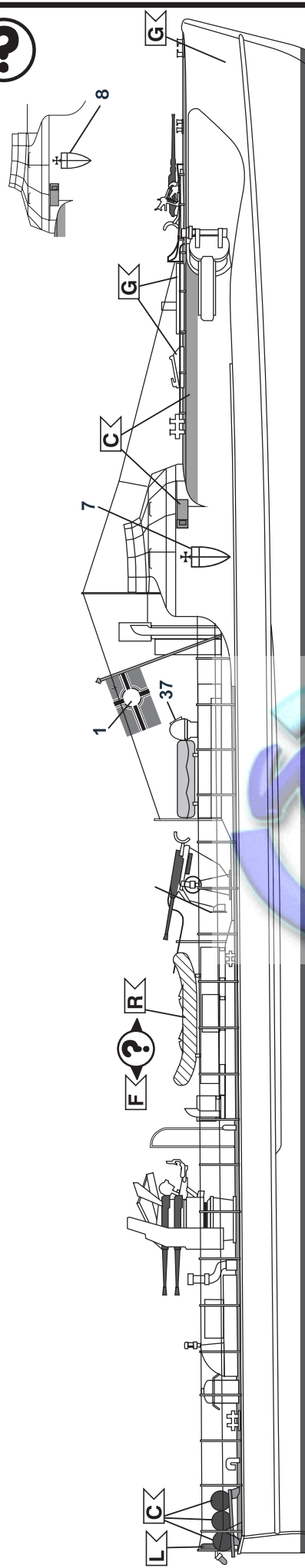

S 188, commanded by Kapitänleutnant Karl-Erhard Karcher, 8th flotilla, based in Boulogne/France, 1944



German Fast Attack Craft S 100-type  
Schnellboot Typ S 100  
alternative 5

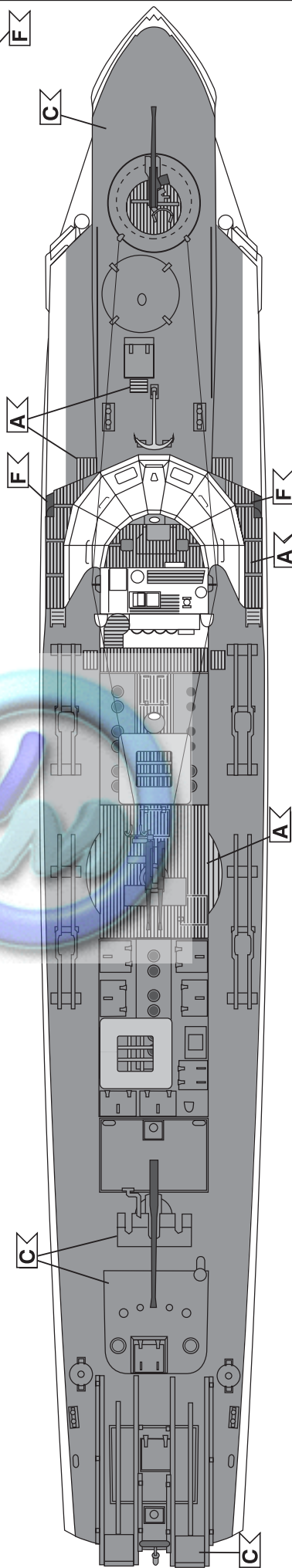
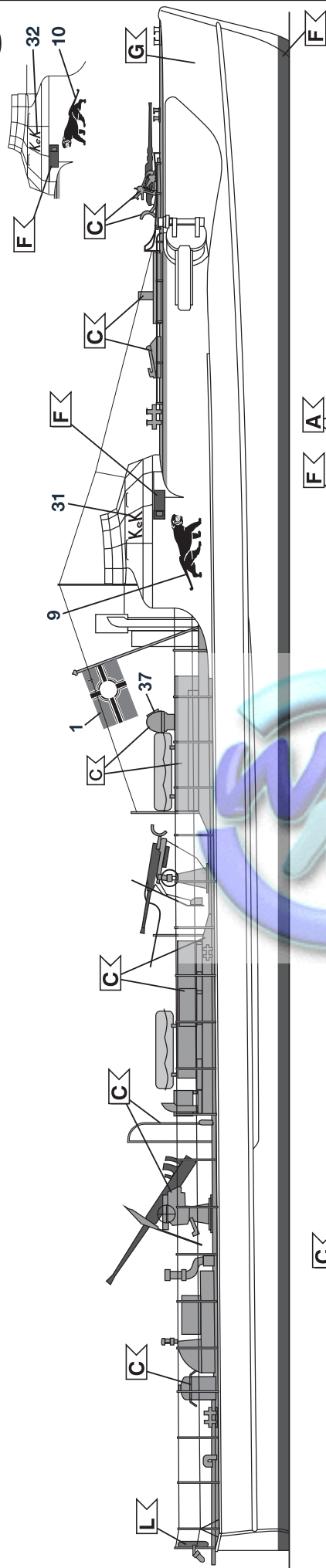

67



S 304, 4th flotilla, based in Rotterdam/Netherland, May 1945

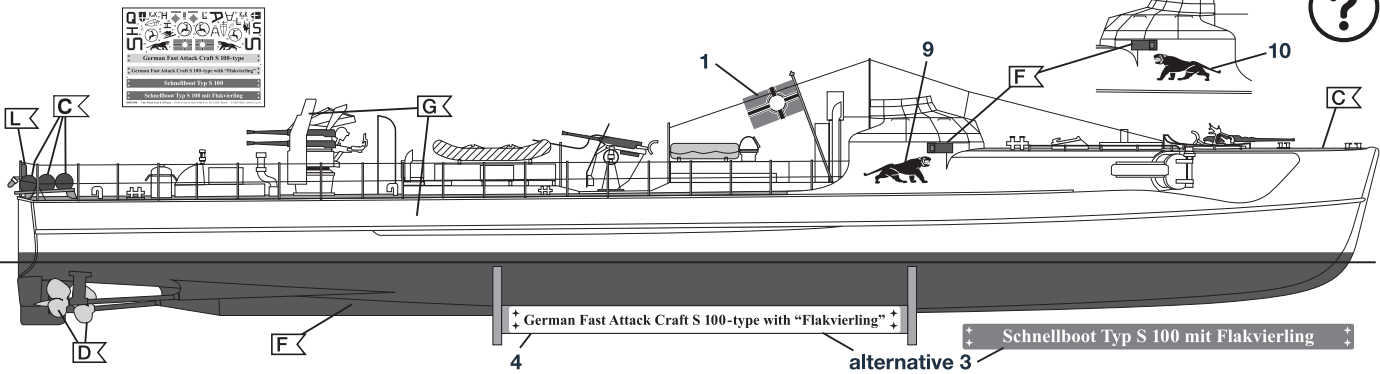

68



S 306, 1th flotilla, based in Gelting/Germany, May 1945

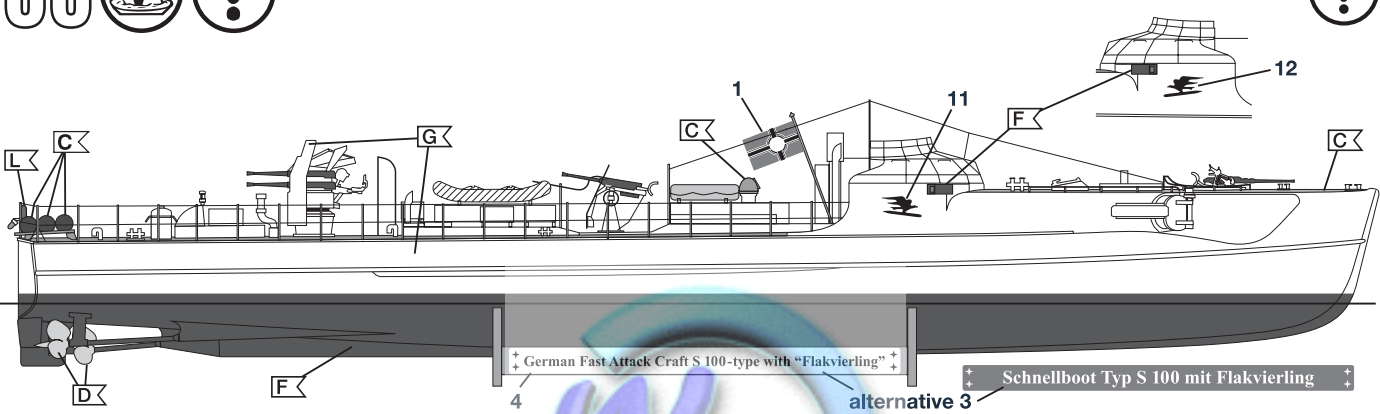

69



S 100-type boat, 2th flotilla, based in Den Helder/Netherland, 1944



70



S 93, 8th flotilla, commanded by Oberleutnant zur See H.-Joachim Quistorp, based in IJmuiden/Netherland, 1944

