

Revell MARMON CONVENTIONAL

7457-0389

©1988 BY REVELL INC.

PRINTED IN W. GERMANY

ENGLISH: ASSEMBLY DRAWINGS SHOULD BE REVIEWED BEFORE PROCEEDING WITH CONSTRUCTION. A NUMBER IDENTIFIES EACH PLASTIC PART FOR YOUR CONVENIENCE. PAINT SMALL PARTS ON RUNNER BEFORE REMOVING. ALLOW PAINT TO DRY THOROUGHLY BEFORE CONTINUING ASSEMBLY OF KIT. SCRAPE CHROME OR PAINT AT AREA TO BE GLUED. WASH PLASTIC IN MILD DETERGENT SOLUTION. RINSE AND LET AIR DRY FOR BETTER PAINT AND DECAL ADHESION.

DEUTSCH: VOR DEM ZUSAMMENBAU DIE BAUANLEITUNG GUT DURCHLESEN. JEDES TEIL IST NUMERIERT. KLEINE TEILE ANSTREICHEN BEVOR SIE VOM RAHMEN ENTFERNT WERDEN. FARBEN GUT TROCKNEN. ERST DANN DEN ZUSAMMENBAU FORTSETZEN. CHROM UND FARBE AN DEN KLEBEFLÄCHEN ENTFERNEN. PLASTIKTEILE IN EINER MILDEN WASCHMITTELÖSUNG REINIGEN UND AN DER LUFT TROCKNEN, DAMIT FARBE U. ABZIEHBILDER BESSER HAFTEN.

FRANCAIS: EXAMINER LES SCHEMAS D'ASSEMBLAGE AVANT DE COMMENCER LA CONSTRUCTION. UN NUMERO IDENTIFIE CHAQUE PIECE DE PLASTIQUE. POUR PLUS DE FACILITE, PEINDRE LES PETITES PEICES SUR LE SUPPORT AVANT DE LES ENLEVER. LAISSER LA PEINTURE SECHER COMPLETEMENT AVANT DE CONTINUER L'ASSEMBLAGE DU KIT. GRATTER LE CHROME OU LA PEINTURE SUR LES SURFACE A COLLER. LAYER LE PLASTIQUE DANS UNE SOLUTION DE DETERGENT LEGERE, RINGER ET LAISSER SECHER A L'AIR POUR UNE MEILLEURE ADHERENCE DE LA PEINTURE ET DES DECALS.

NEDERLANDS: BESTUDEER DE MONTAGE TEKENINGEN, VOORDAT U MET BOUWEN BEGINT. VOOR UW GEMAK, IDENTIFICEERT EEN NUMMER ELK PLASTIC DEEL. VERF KLEINE DEELTJES OP KIBOOM VOORDAT U ZE VERWYDERD. LAAT VERF GRONDIG DROGEN VOORDAT U DE MONTAGE VAN HET MODEL VOORTZEI. SCHRAP CHROOM OF VERF VAN HET GODEELTE DAT GELYMD WORDT. WAS PLASTIC MET EEN ZACHTE ZEEP. SPOEL AF, EN LAAT IN LUCHT DROGEN, ZODAT VERF EN DECAL BETER PLAAKEN.

SVENSKA: IHOPSÄTTNINGSSKISSEN BÖR GRANSKAS INNAN IGÅNGSÄTTANDE AV BYGGANDET. ETT NUMMER IDENTIFIKERAS VARJE PLASTDEL FÖR DIN EGEN BEKVÄMLIGHET. MALA DE SMA BITARNA DIREKT PÅ FARAN INNAN DE TAS BORT. LÄT FARGEN TORKA GRUNDLIGT INNAN FORTSÄTT BYGGANDE. SKRAPA AV KROMEN ELLER MALA PÅ DELARNA SOM SKALL KLISTRAS. TVÄTTA PLASTEN I MILD TVÄTTMEDELÖSNING. SKOJ OCH LUFTTORKA FÖR BÄTTR FASTANDE AV FARG OCH DEKALER.

ESPAÑOL: DIBUJOS DE ENSAMBLAJE DEBEN SER REPASADOS ANTES DE SEGUIR CON LA CONSTRUCCION. UN NUMERO IDENTIFICA CADA PARTE DEL PLASTICO PARA SU CONVENIENCIA. PINTÉ PARTES PEQUEÑAS DEL KIT ANTES DE QUITARLAS. DEJE SECAR BIEN LA PINTURA ANTES DE SEGUIR EL ENSAMBLAJE. RASPE EL CROMO O LA PINTURA DEL SITIO ANTES DE SER PEGADO. LAVE EL PLASTICO EN UNA SOLUCION SUAVE DETERGENTE, ENJUAGUE, Y DEJE SECAR EN EL AIRE PARA MEJOR ADHESION DE LA PINTURA Y CALCOMANIA.

ITALIANO: I DISEGNI DELL'ASSEMBLAGGIO DOVREBBERO ESSERE RICONTROLLATI PRIMA DI INIZIARE IL MONTAGGIO. OGNI PEZZO È IDENTIFICATO DA UN NUMERO PER VOSTRA MAGGIORE COMODITÀ. VERNICIARE LE PARTI PICCOLE SULLA GUIDA DE SCORRIMENTO PRIMA DE TOGLIERLE. LASCIAR ASCIUGARE LA VERNICE PRIMA DI CONTINUARE IL MONTAGGIO. RASCHIAR LA PITTURA O IL CROMO DALLE PARTI CHE DEVONO ESSERE INCOLLATE. LAVARE I PEZZI DI PLASTICA CON UN DETERGENTE NON TROPPO FORTE, SCIAQUARE E LASCIAR ASCIUGARE AFFINCHÉ VERNICE E DECALCOMANIE ADERISCANO MEGLIO.



GLUE
KLEBEN
COLLE
LIJM
KLISTER
PEGA
COELA



NO GLUE REQUIRED
NICHT KLEBEN
LA COLLE N'EST PAS NECESSAIRE
GEEN LIJM NODIG
INGET KLISTER BEHOVS
NO NECESITA PEGA
NON C'E BISOGNO DI COLLA



DO IT THIS MANY TIMES
ANZAHL DER ARBEITSGÄNGE
LE FAIRE CE NOMBRE DE FOIS
DOE HET ZOVEEL KEER
GJOR DET SA MANGA GÅNGER
FATELO TUTTE QUESTA VOLTE
HAGALO ESTA CANTIDAD DE VECES



OPTIONAL
WAHLWEISE
FACULTATIF
NAAR KEUZE
VALFRI
FACOLTATIVO
OPCIONAL



APPLY DECALS
ABZIEHBILDER ANBRINGEN
COLLER LES DECALCOMANIES
BRENG PLAATJES AAN
SATTI PA DEKALERNA
APPLICARE LE DECALOMANIE (ADESIVI)
APLICAR CALCAS



SHOWN ASSEMBLED
ABBILDUNG ZUSAMMENGEBAUTER TEILE
YU ASSEMBLE
GEMONTÉERD GETOOND
VISAD IHOPSÄTTNING
MOSTRADO ARMADO
ILLUSTRAZIONE DEL PEZZO MONTATO



CLEAR
KLARSICHTTEILE
TRANSPARENT
DOORZICHTIG
KLART
VIA LEBERA
TRANSPARENTE



BLACK
SCHWARZ
NOIR
ZWART
SVART
NEGRO
NERO



CHROME
CHROM
LE CHROME
CHROOM
AV KROMEN
EL CROMO
IL CROMO

PARTS NOT USED
NICHT BENÖTIGTE BAUTEILE
PIECES NON UTILISEES
DEELEN NIET GEBRUIKT
DELAR INTE ANVÄNDA
PARTI NON USATE



Should you find any missing parts, please write to REVELL PLASTICS GMBH, 26 09 + 26 20, department X, D-4980 Bünde, W. Germany, and we will send you these as quickly as possible with our compliments. Please indicate clearly with a cross on the instruction leaflet, which piece(s) are missing. Always remember to write your name and address clearly and in full. Upon receipt of your International Reply Coupons to the value of £ 1.00 you will promptly receive the parts required.

Pour toute pièce manquante, écrivez à REVELL PLASTICS GMBH, Postbus 26 09 + 26 20, département X, D-4980 Bünde, et cet élément vous sera aussitôt envoyé et ce, gratuitement. Il vous suffit dans ce cas de marquer d'une croix la pièce manquante sur la feuille d'instruction du modèle choisi. N'oubliez surtout pas d'écrire clairement votre nom et adresse. Des réception de vos Coupon-Réponse International de FB 60.-/FFr. 10.- vous recevrez par retour les pièces requises.

Zou het voorkomen, dat er een deel in de bouwdoos ontbreekt, kunt U schrijven naar REVELL PLASTICS GMBH, Postbus 26 09 + 26 20, Afdeling X, D-4980 Bünde. De bouwbeschrijving waarop het ontbrekende deel aangekruist is, bijsluiten, anders kunnen wij U dit onderdeel niet vergoeden. Vergeet vooral niet Uw naam en adres duidelijk te vermelden. Tegen opsturen van HFI 3.-/BFR 60.-, in Internationale Antwoordcoupons (IRC) krijgt U per omgange de gewenste onderdelen.

Sollte es einmal vorkommen, daß ein Teil im Bausatz fehlt, bitte an REVELL PLASTICS GMBH, Postfach 26 09 + 26 20, Abteilung X, 4980 Bünde, schreiben und die Bauanleitung, auf der das fehlende Teil angekreuzt ist, mitschicken, sonst können wir keinen Ersatz leisten. Gegen Einsendung von 2,50 DM in Briefmarken erhalten Sie umgehend die gewünschten Teile.

7457

<p>A</p> <p>MID GREY MITTELGRAU 374 GRIS MOYEN MIGLIORIS MEL ANGRA GRIGIO MEDIO</p>	<p>B</p> <p>MATT BLACK MATT SCHWARZ B NOIR MAT MAT ZWART MATT SWART NITRO SMORTO</p>	<p>C</p> <p>SILVER SILBER 90 AICENT ZILVER SILVER ARGENT C</p>	<p>D</p> <p>MATT MEDIUM GREY MATT MITTELGRAU 77 GRIS MOYEN MAT MAT M'DOELGRIS MATT M'ALINGRA GRIGIO MEDIO SMORTO</p>	<p>E</p> <p>MATT STEEL GREY MATT STAHLGRAU 47 GRIS D'ACIER MAT MAT S'ALGRIS STALGRA GRIGIO ACC A O SMORTO</p>	<p>F</p> <p>MATT MEDIUM BLUE MATT MITTELBLAU 55 BLAU M'ATIE MAT MATT LICHTBLAUW MATT LUSSE A AZZURRO SMORTO</p>	<p>G</p> <p>WHITE WEISS 4 BLANC WIT BIANCO</p>
<p>H</p> <p>ORANGE ORANGE 30 ORANGE ORANJE ORANGE FRANCO</p>	<p>I</p> <p>RED ROT 31 ROUGE ROUGE ROCC ROSSO</p>	<p>J</p> <p>D. AMOND BLUE DIAMANTBLAU 395 S. EV. DIAMANT DIAMANTE AUV DIAMANT BLA BLU DIAMANT</p>	<p>K</p> <p>BLACK SCHWARZ 302 NOIR ZWART SWART NERO</p>	<p>L</p> <p>METALLIC GREY EISENFARBIG 91 GRIS METALLIQUE S. F. COULEUR JARNGRA FERRO</p>		

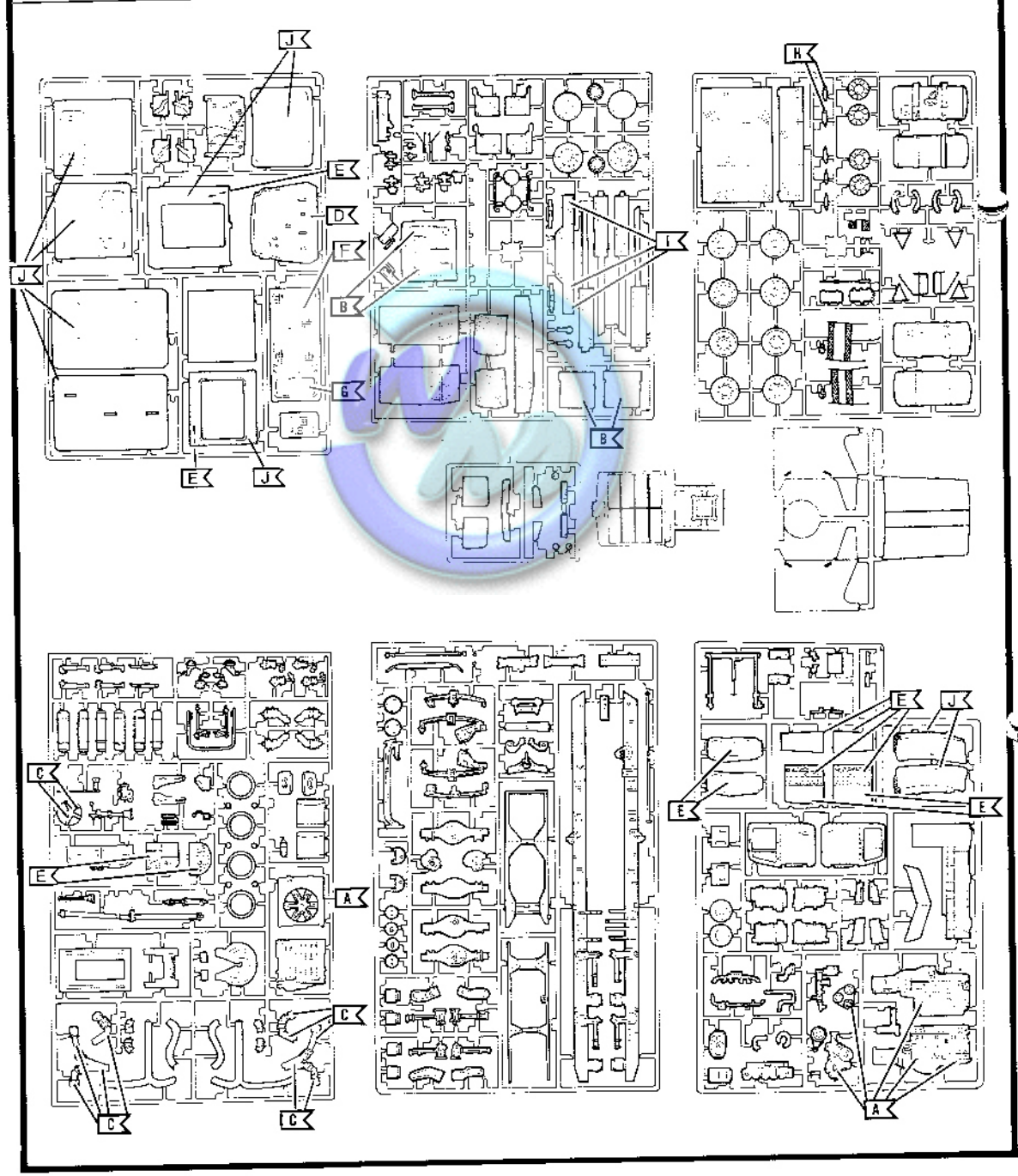

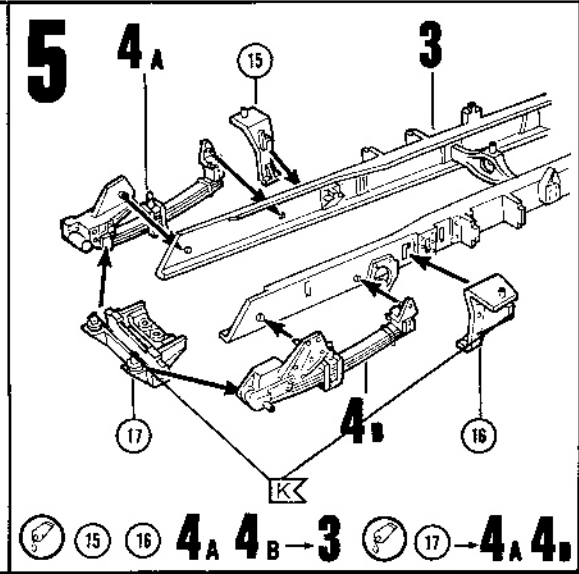
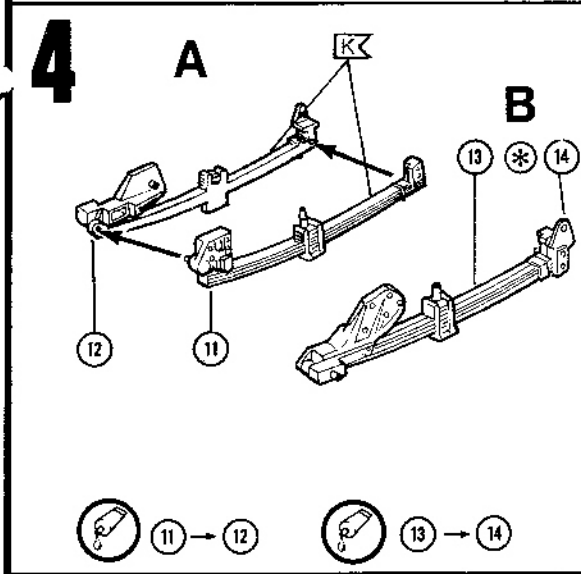
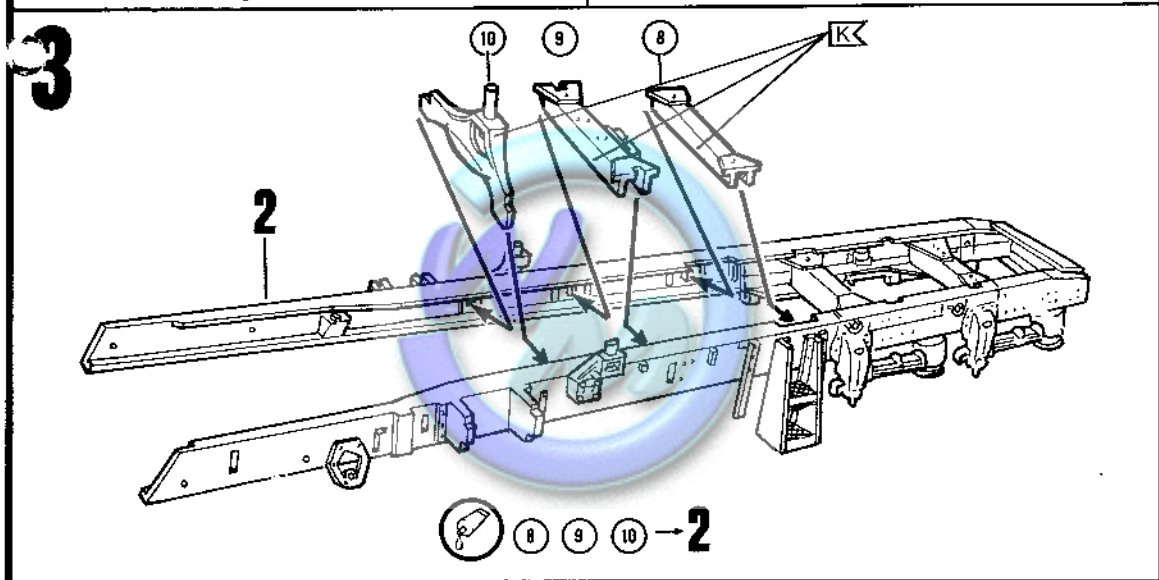
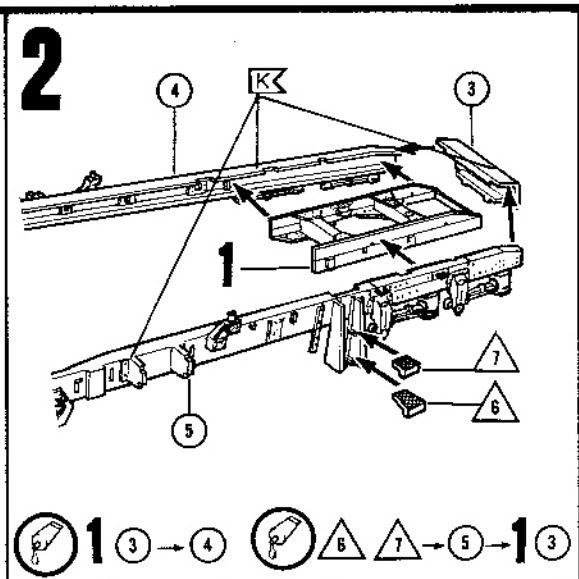
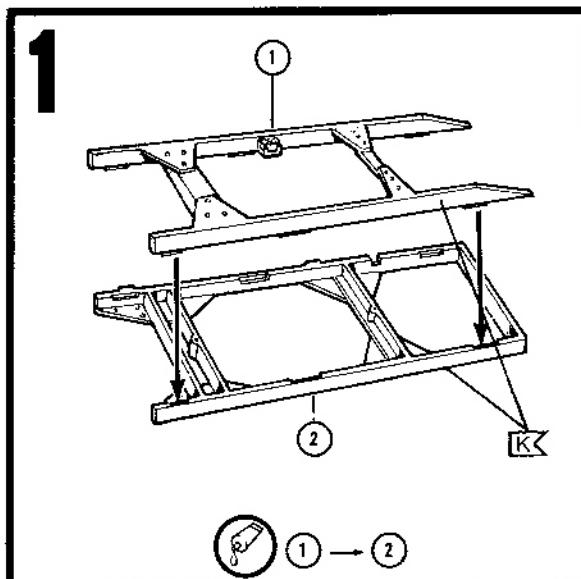

7457

6

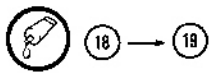
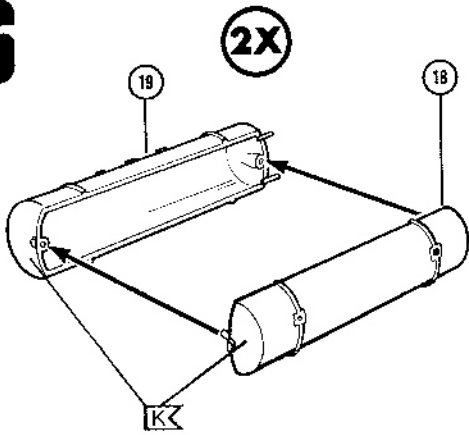

7

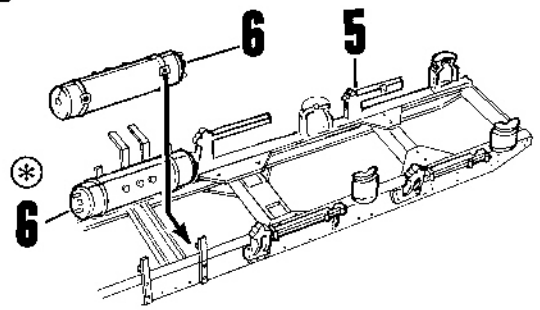

8

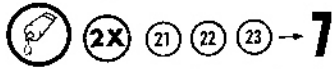
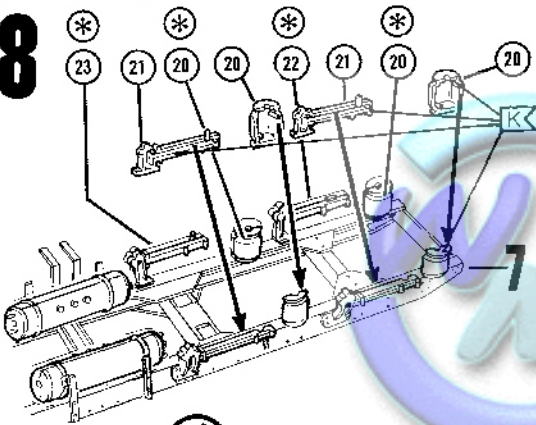

9

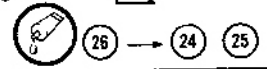
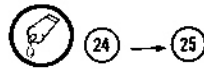
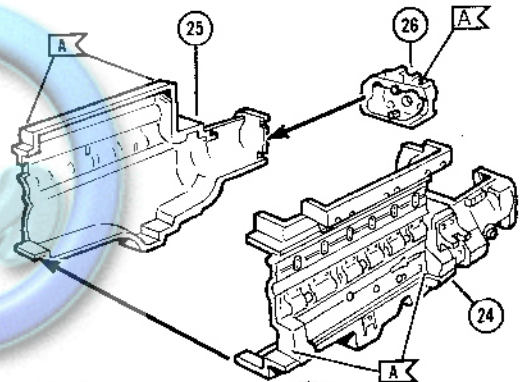

10

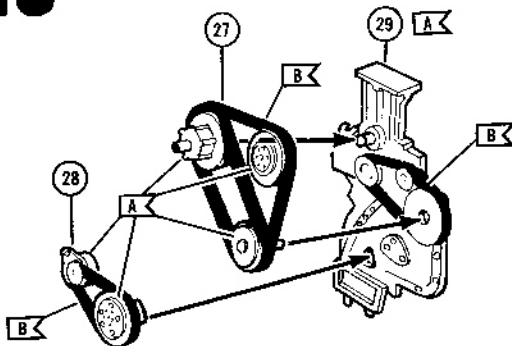

11

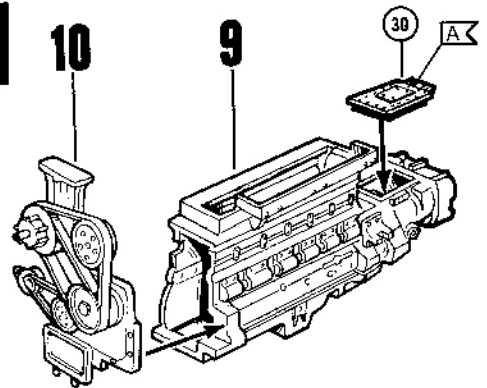

12

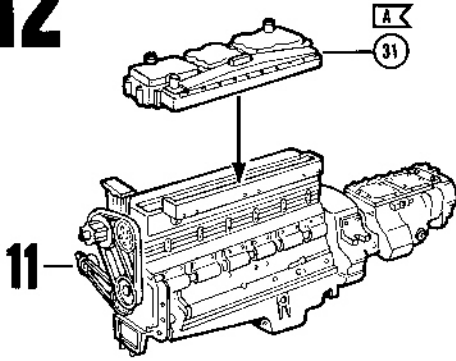

 31 → 11

13

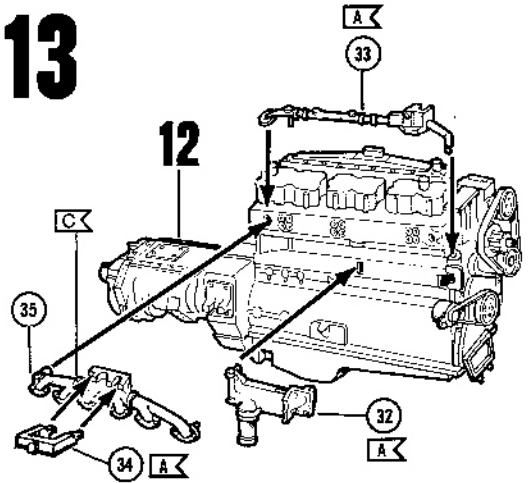



 32 33 → 12  34 → 35 → 12

14

A

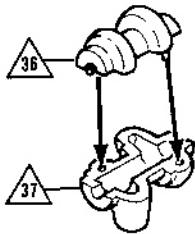
B



 36 → 37

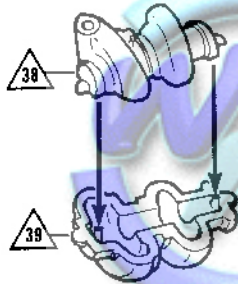

 38 → 39

15

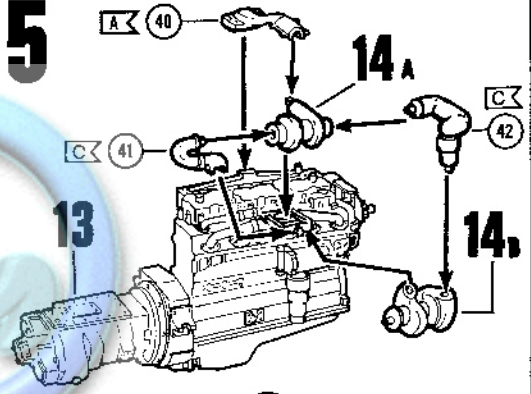

 14 A → 13  40 → 13 14 A
 14 B → 13  41 42 → 14 A-B

16

15

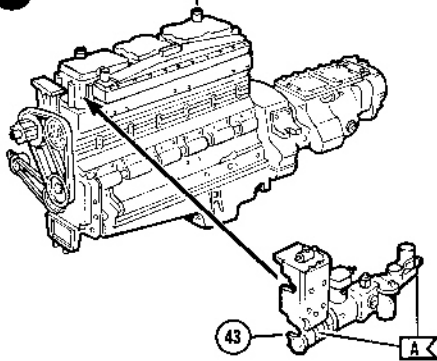

 43 → 15

17

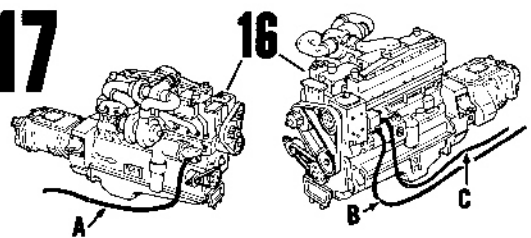

A
B
C

CUT TUBING TO LENGTH
 KABELROHR AUF RICHTIGE LÄNGE SCHNEIDEN
 COUPEZ LA TUYAUTERIE A LA LONGUEUR DESIREE
 HAK HET BUISWERK OP GROTE AF
 KAPA SIANGAR I LANGDER
 TAGLIARE I TUBI ALLA LUNGHEZZA INDICATA
 CORTAR TUBO A LA LONGITUD DESEADA

 A B C → 16

7457

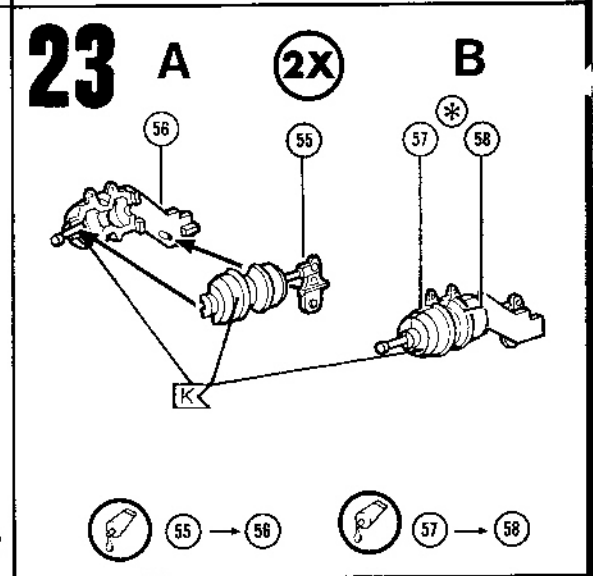
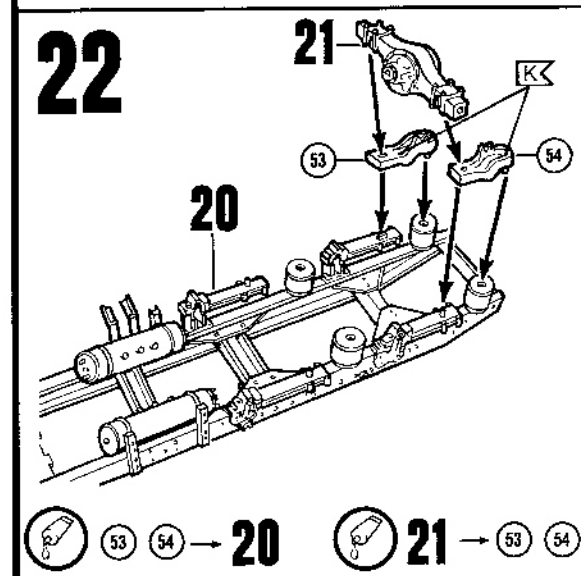
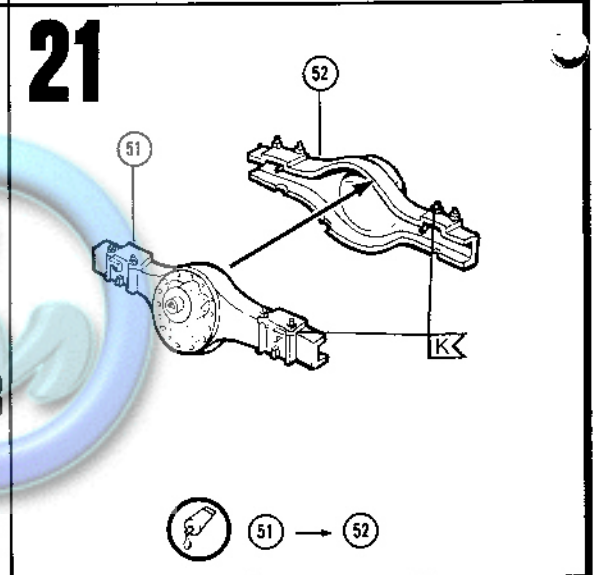
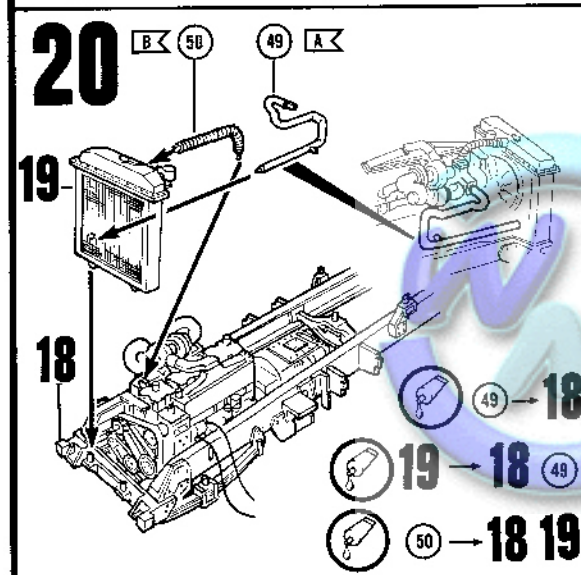
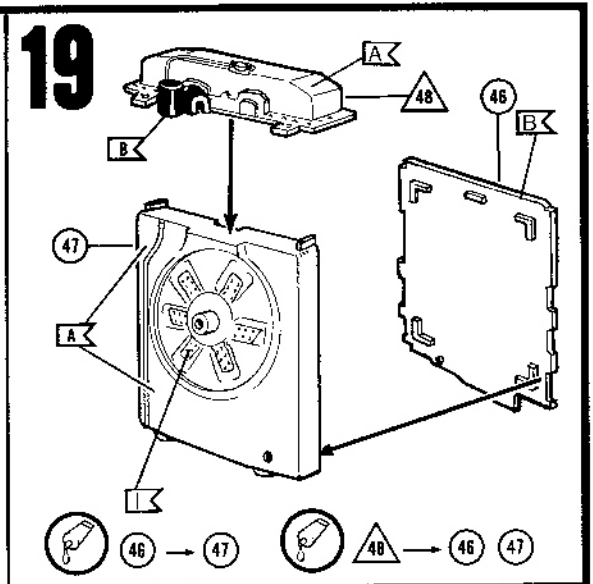
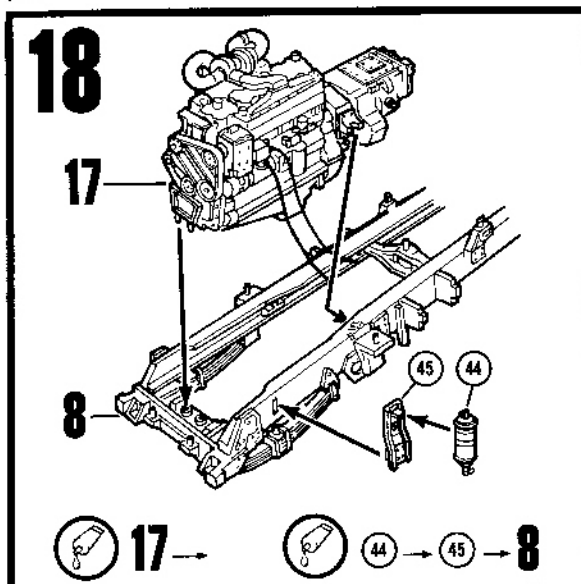

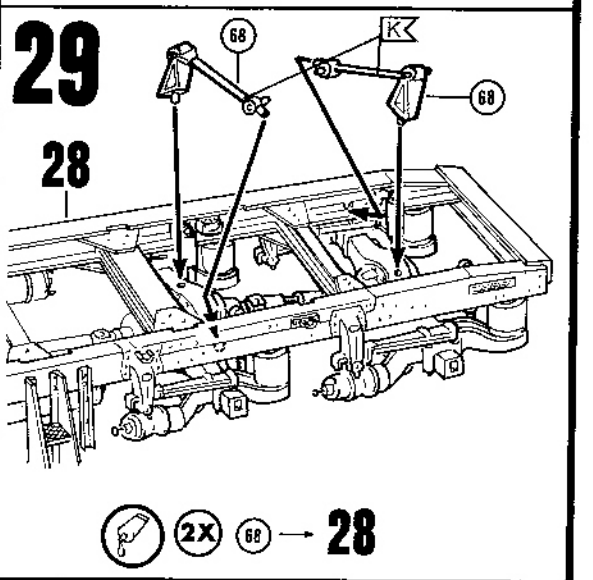
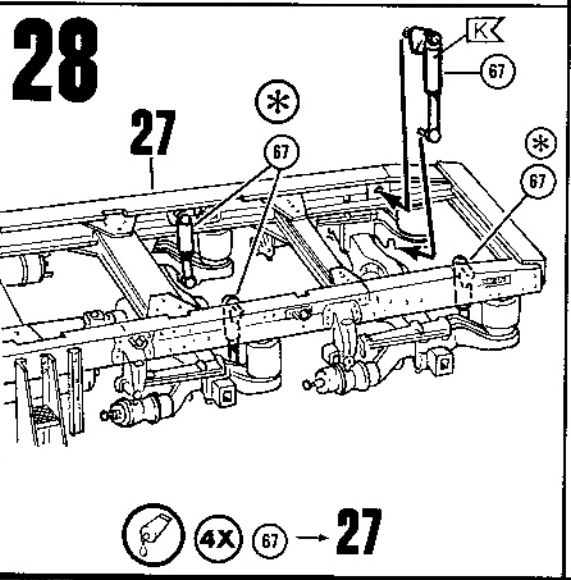
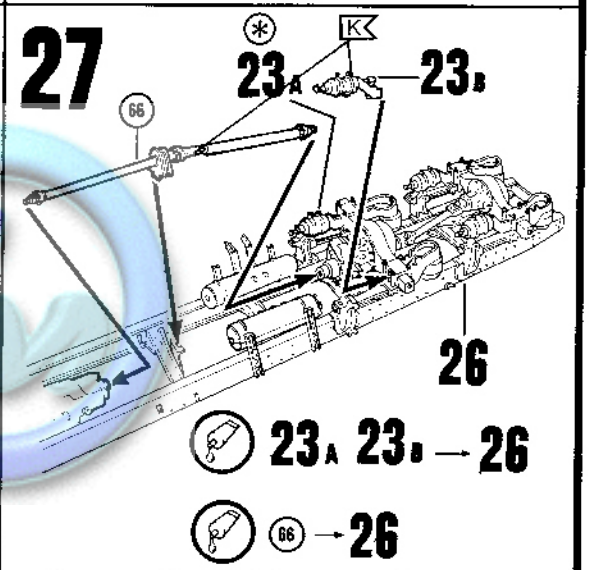
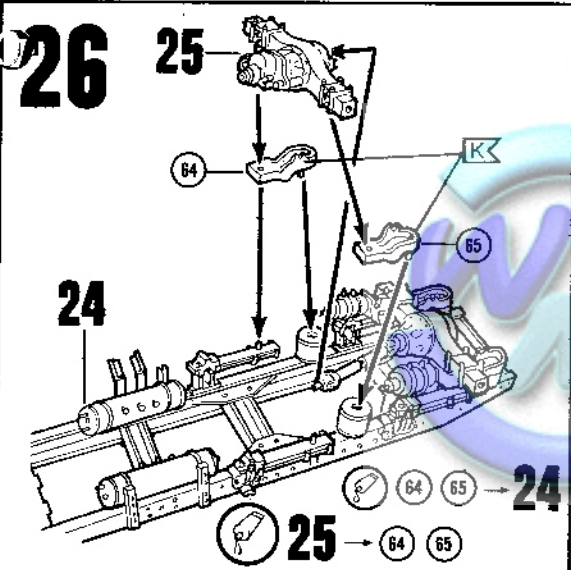
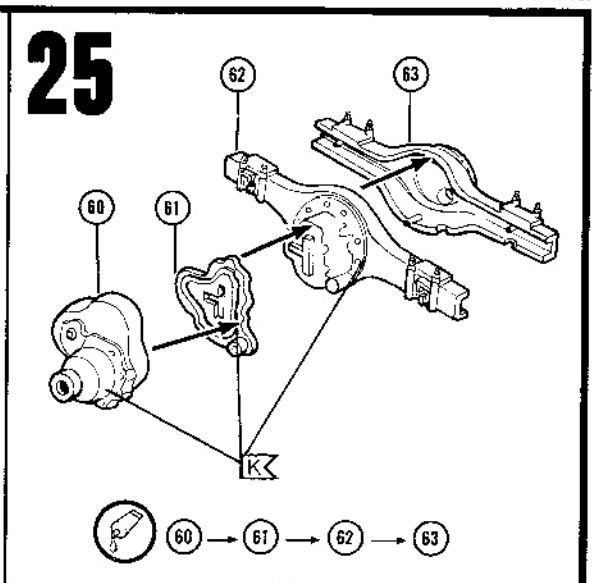
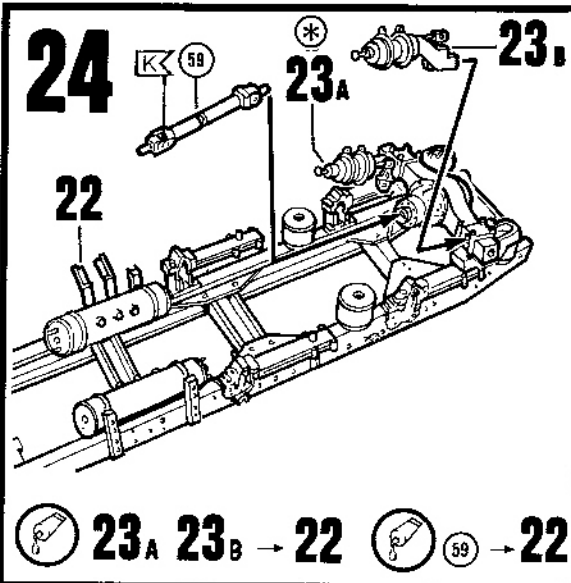

7457

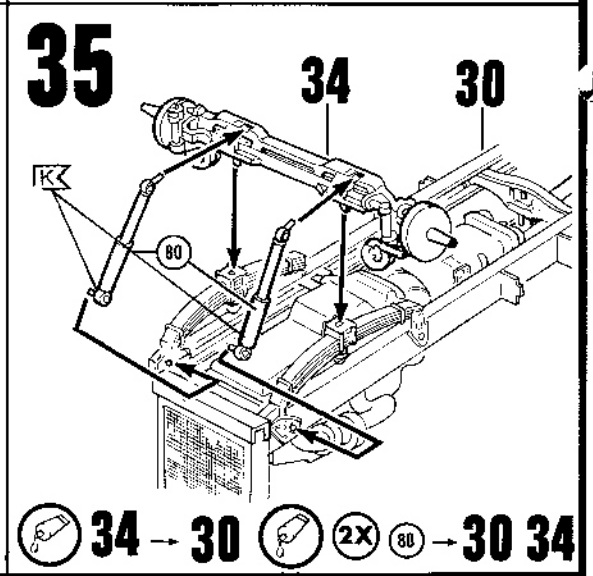
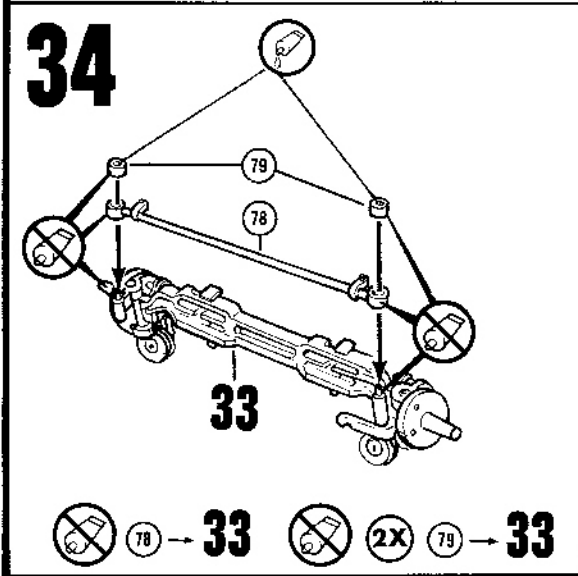
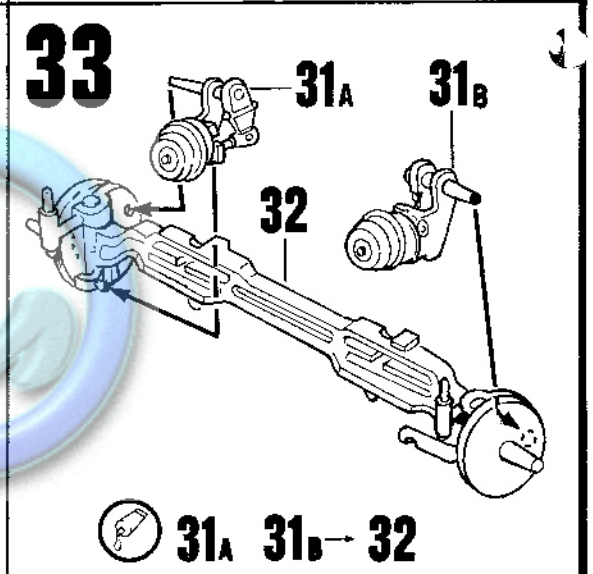
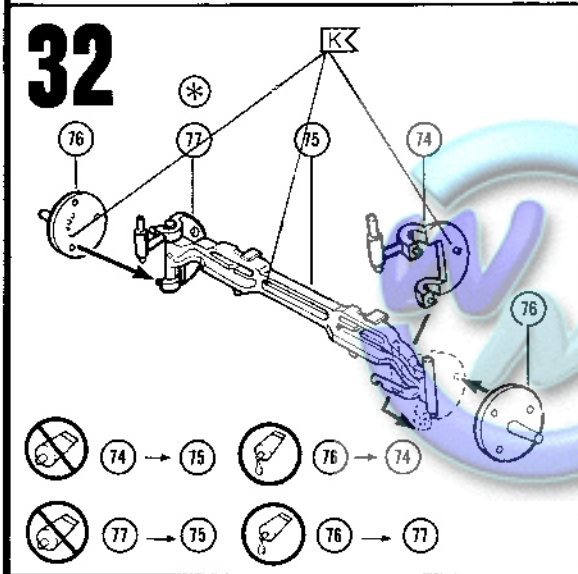
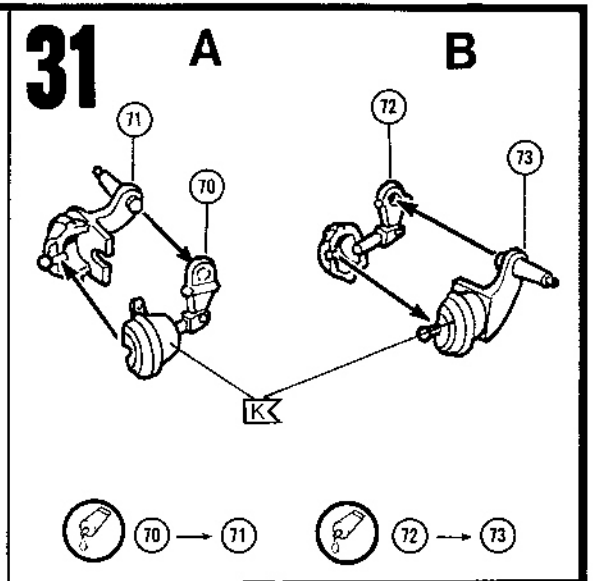
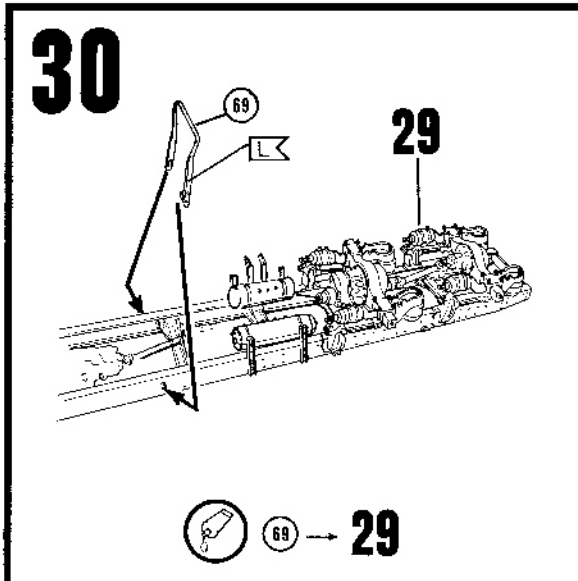

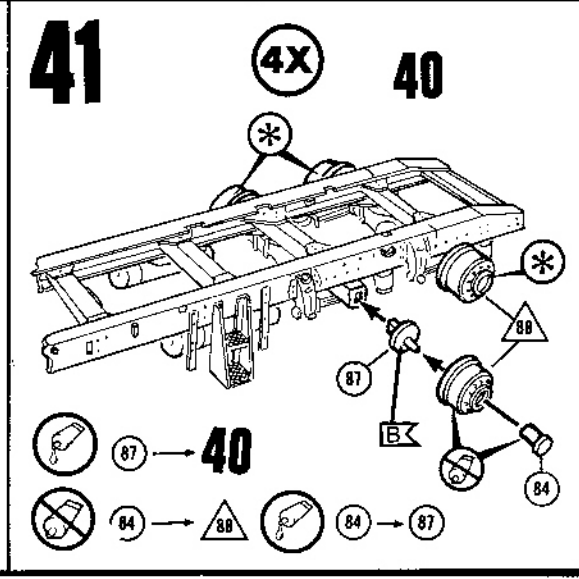
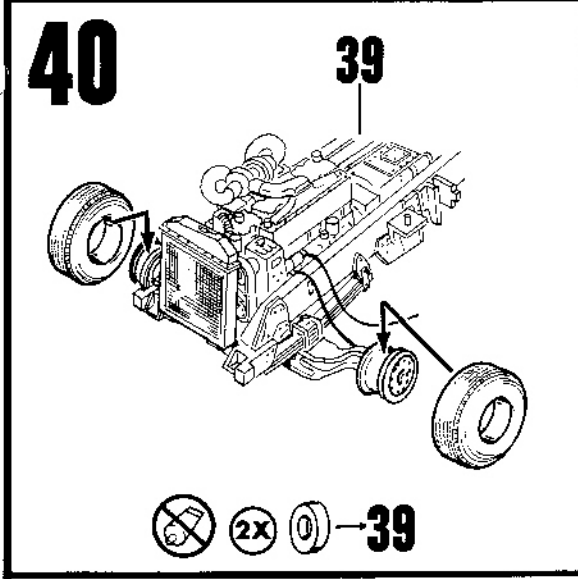
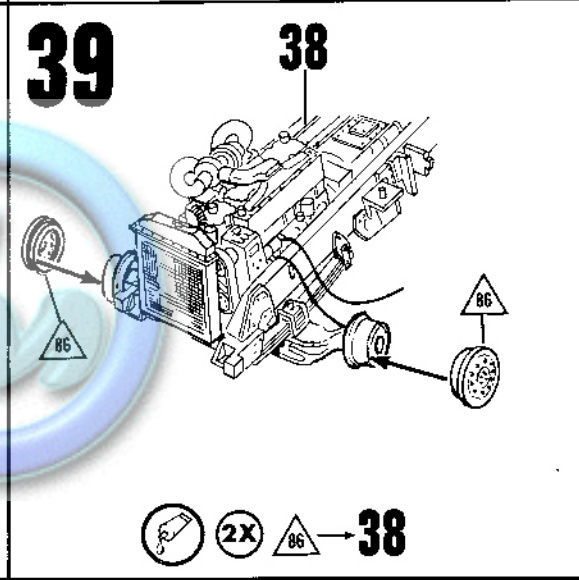
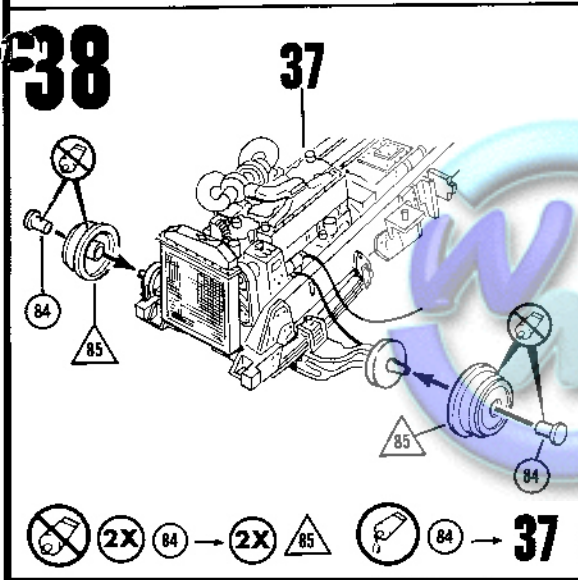
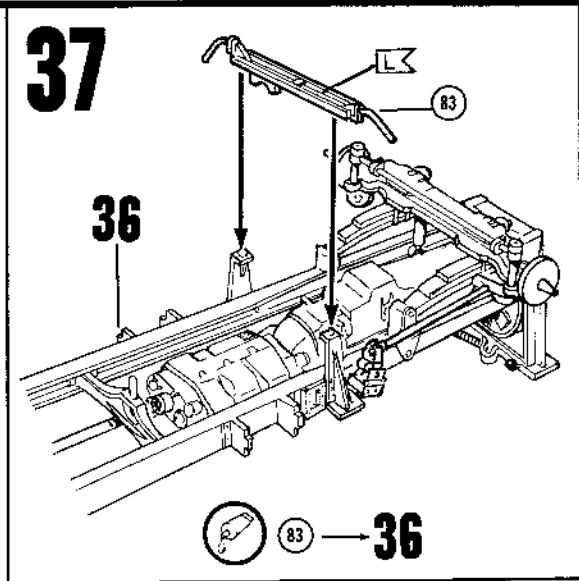
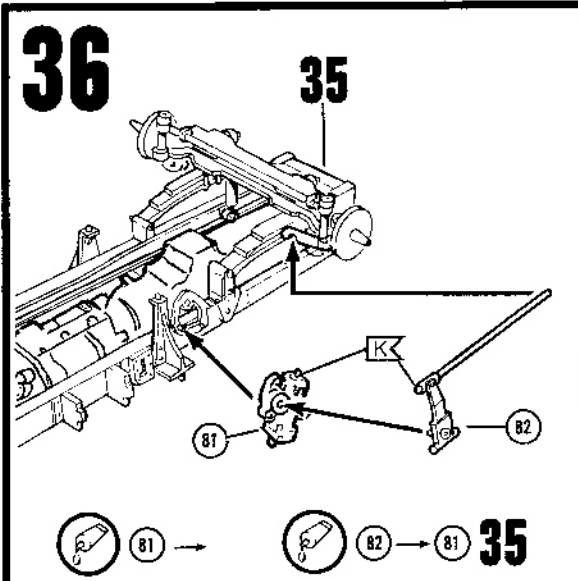

7457

42

4X

?

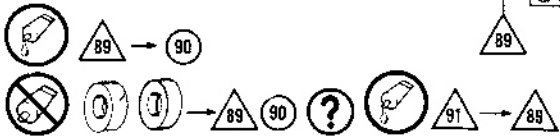
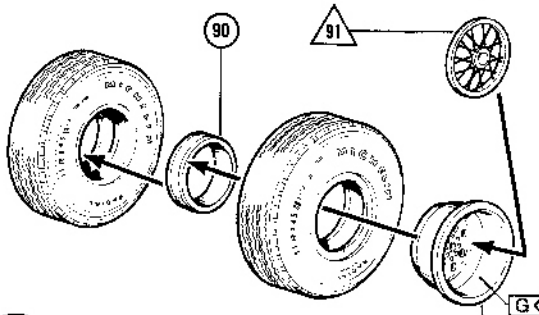

43

*

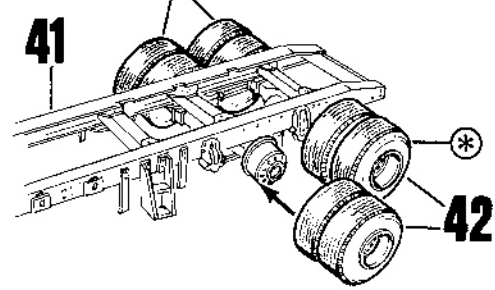

42 → 41

44

2X

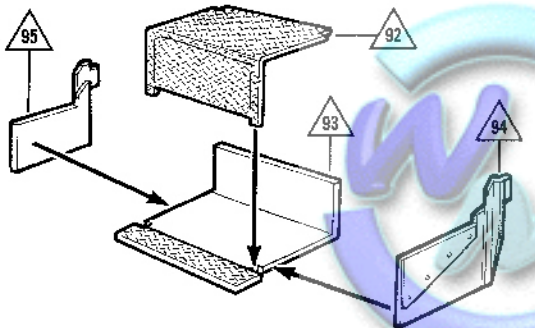

45

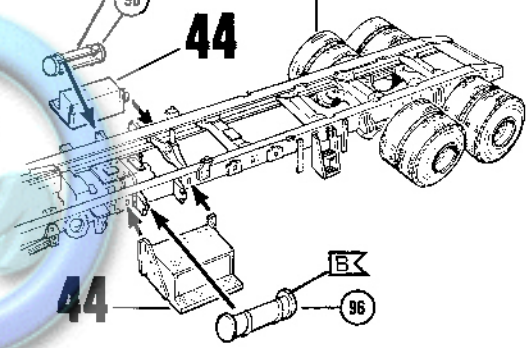

44 → 43 2X 96 → 43

46

2X

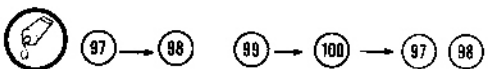
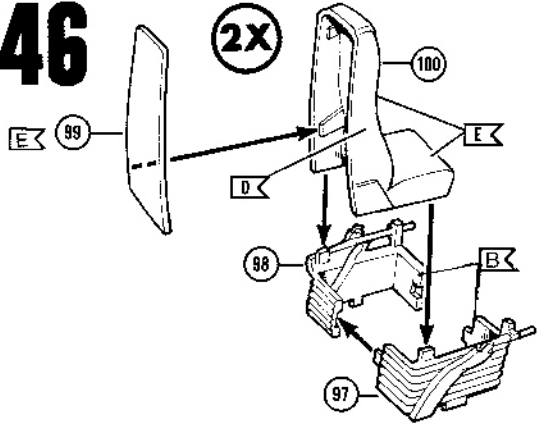

47

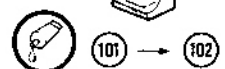
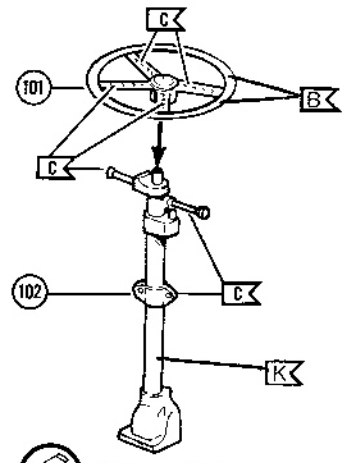

48

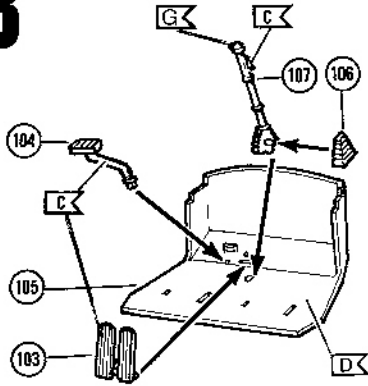

49

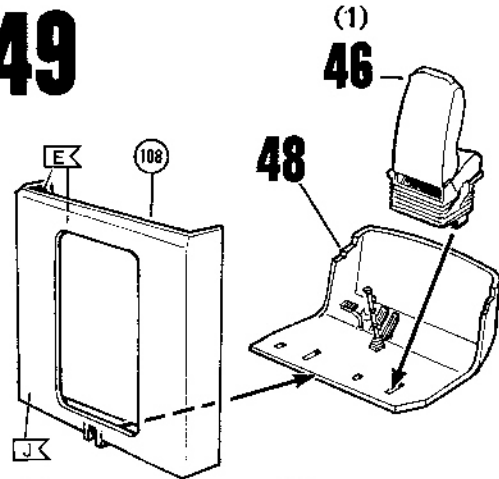

50

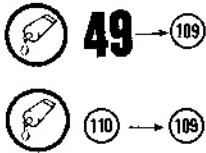
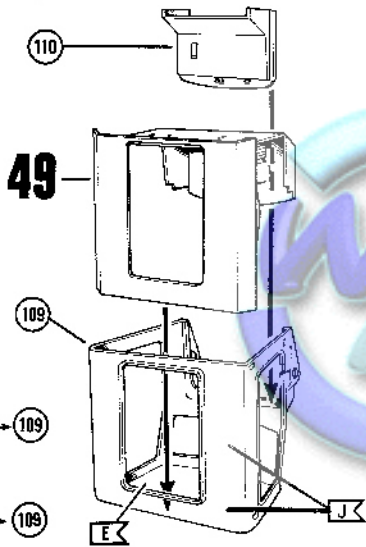

51

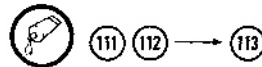
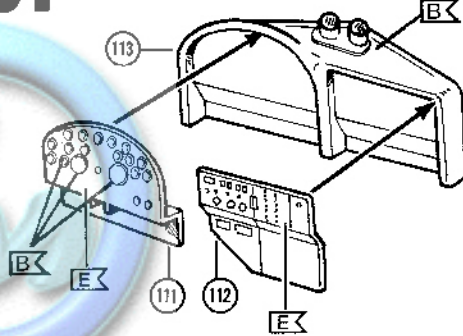

52

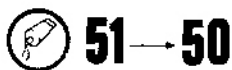
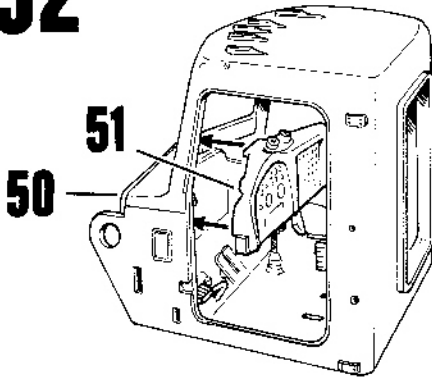

53

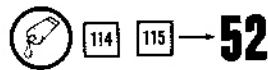
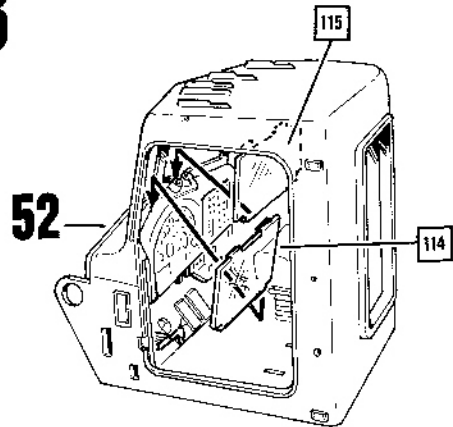

7457

54

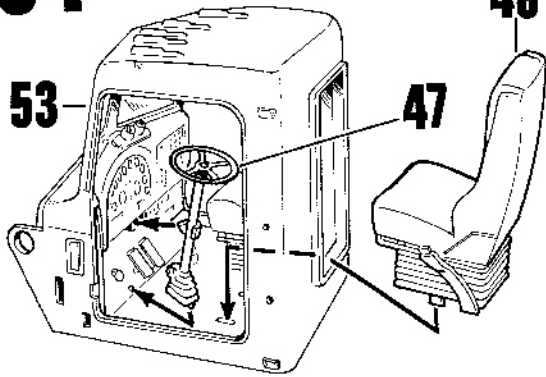

- 47 → 53
- 46 → 53

55

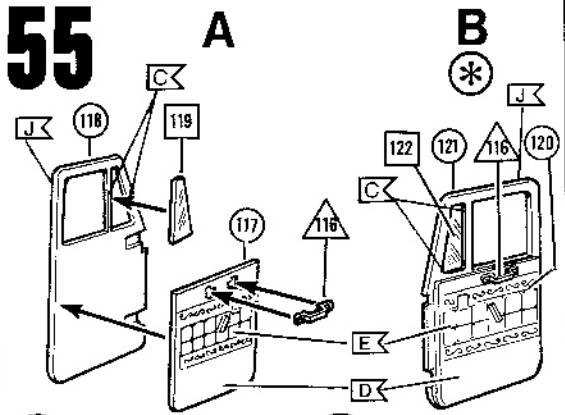

- 116 → 117 → 118
- 119 → 118
- 116 → 120 → 121
- 122 → 121

56

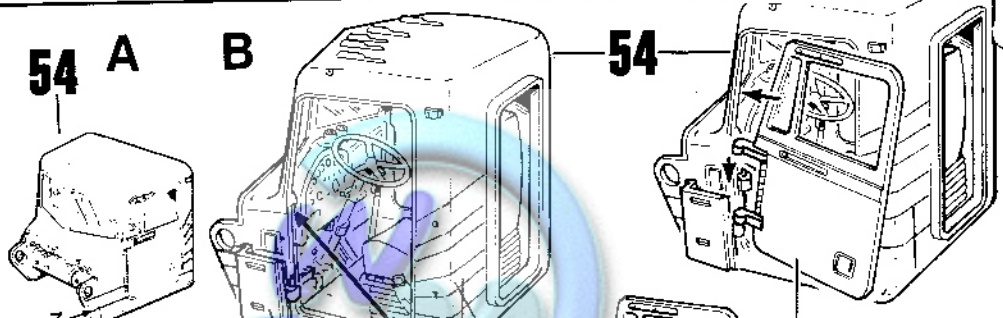

- 7, 9 → 54
- 123, 124 → 54
- 2X 125 → 55A
- 55A → 123, 124

57

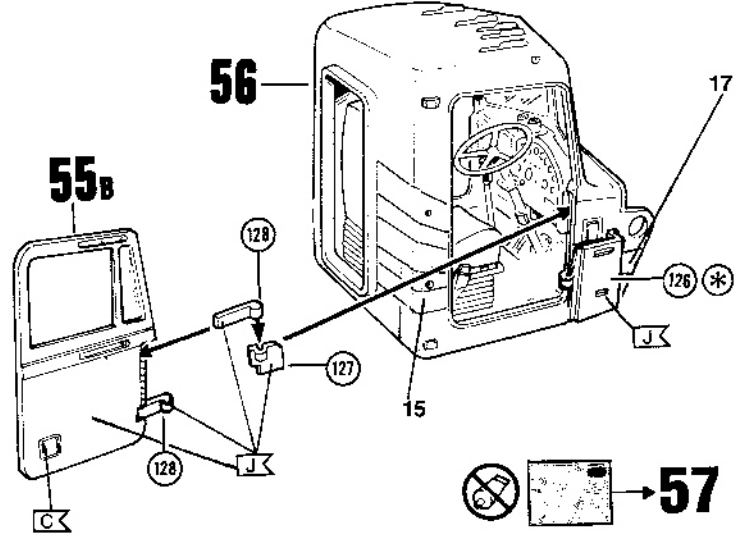

- 126, 127 → 56
- 2X 128 → 55B
- 55B → 126, 127
- [Diagram] → 57

58

45

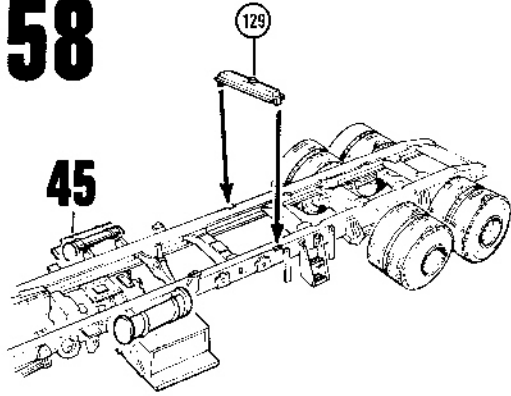

129 → 45

59

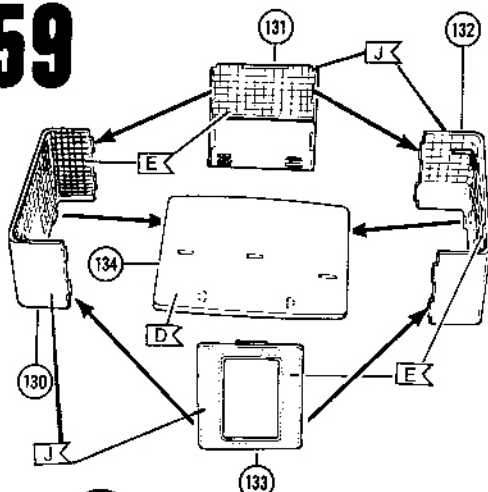

130 131 132 133 → 134

60

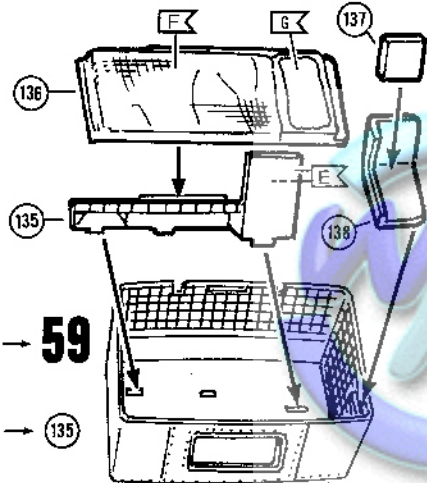

135 → 59

136 → 135

137 → 138 → 59

61

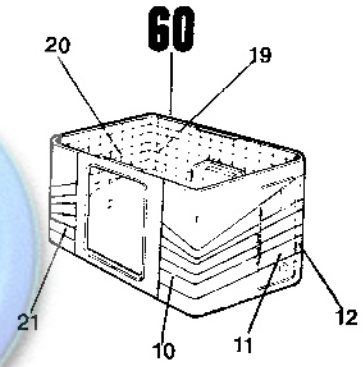

10, 11, 12, 20, 21, 19 → 60

62

56A

61

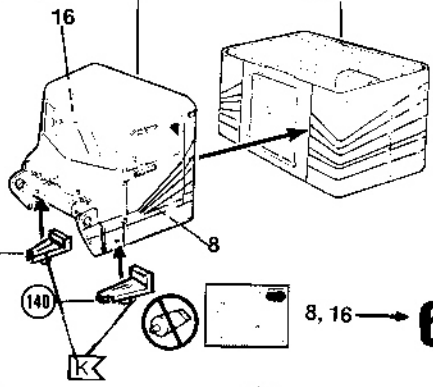

8, 16 → 62

139 140 → 56A

56A → 61

63

62

58

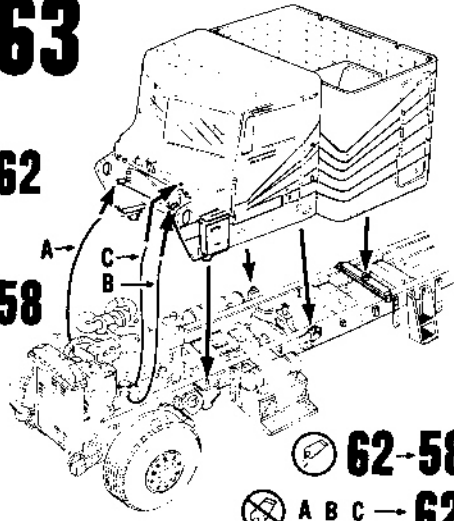

62 → 58

A B C → 62

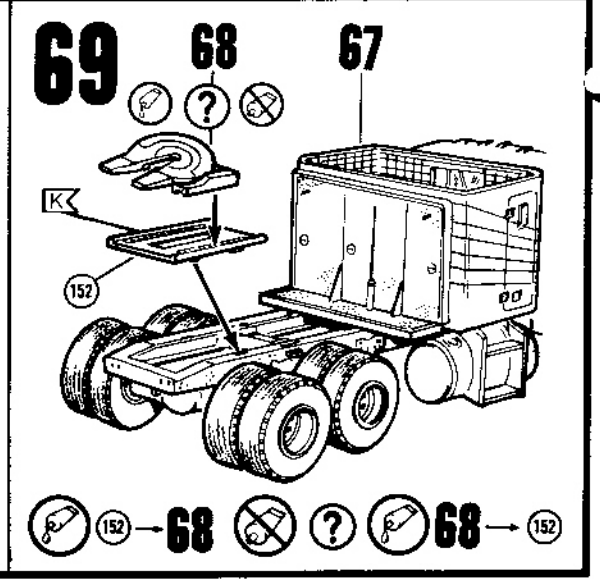
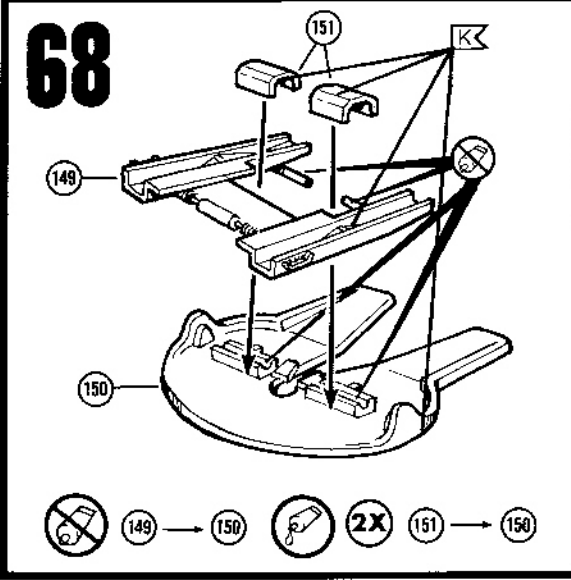
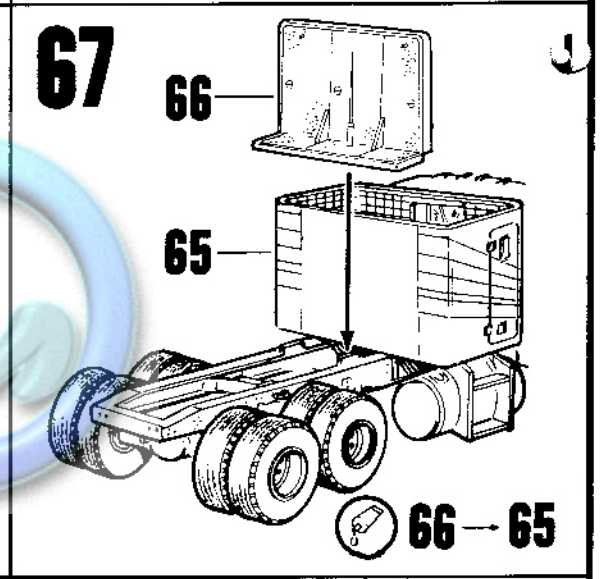
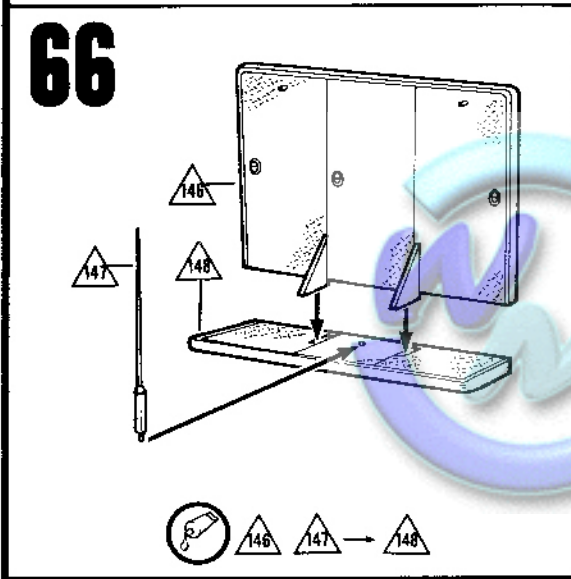
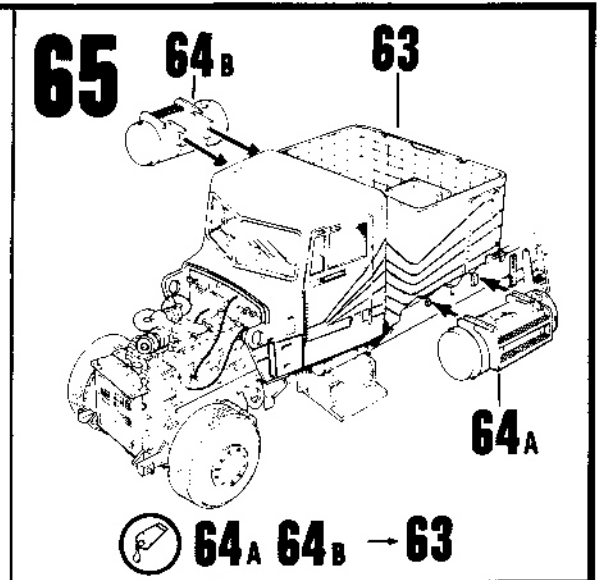
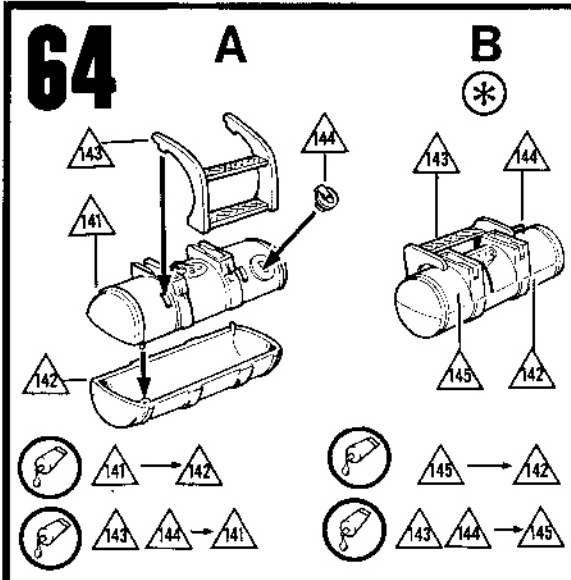

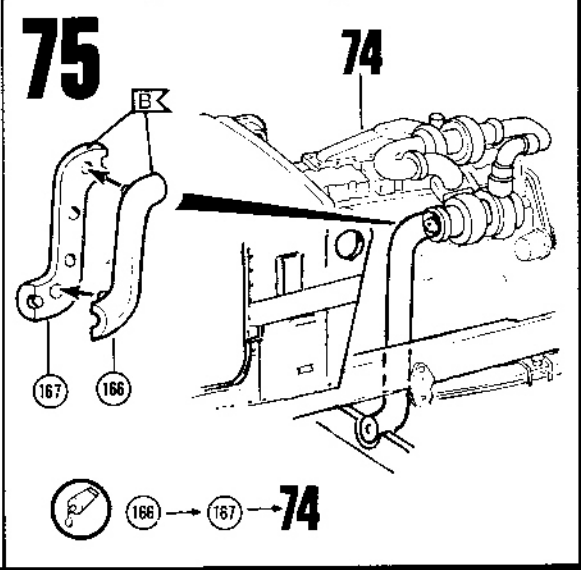
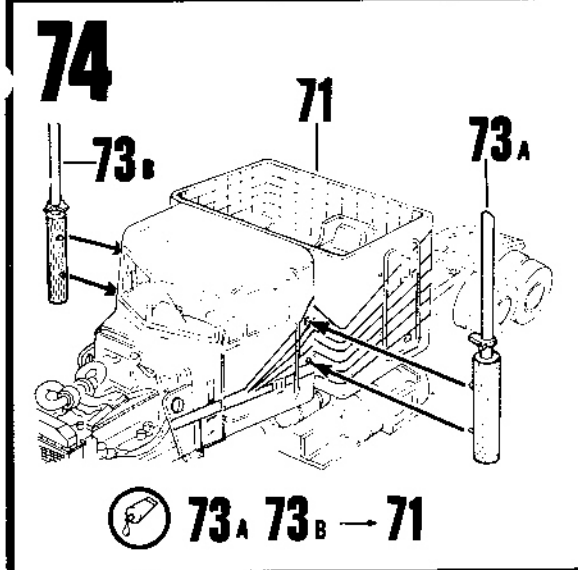
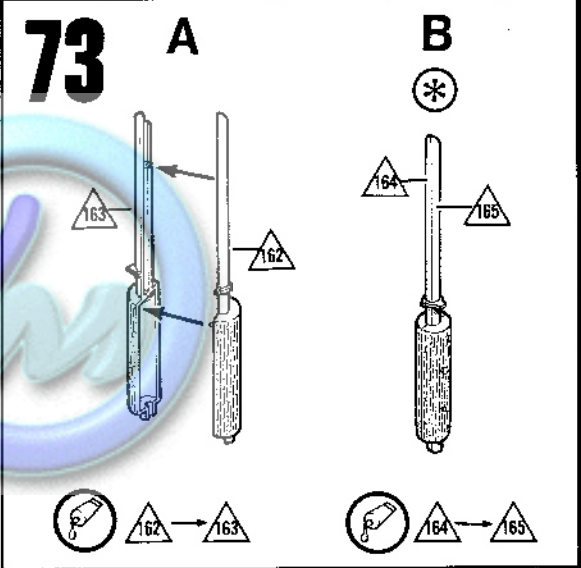
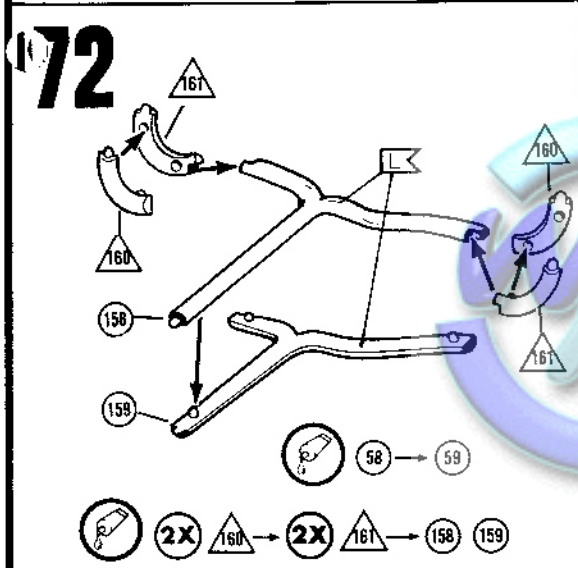
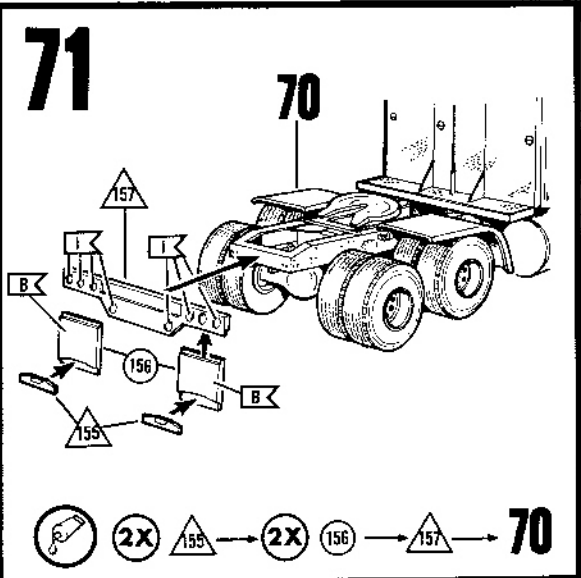
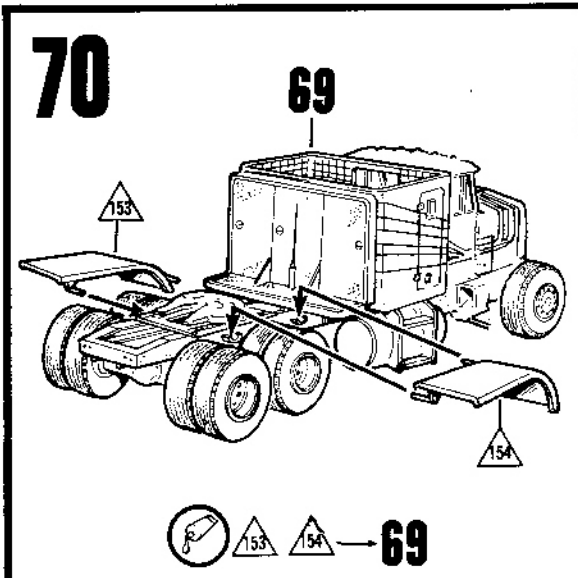

7457

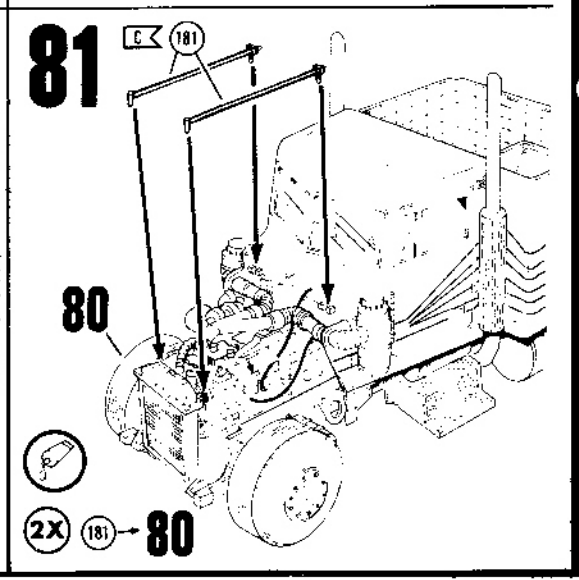
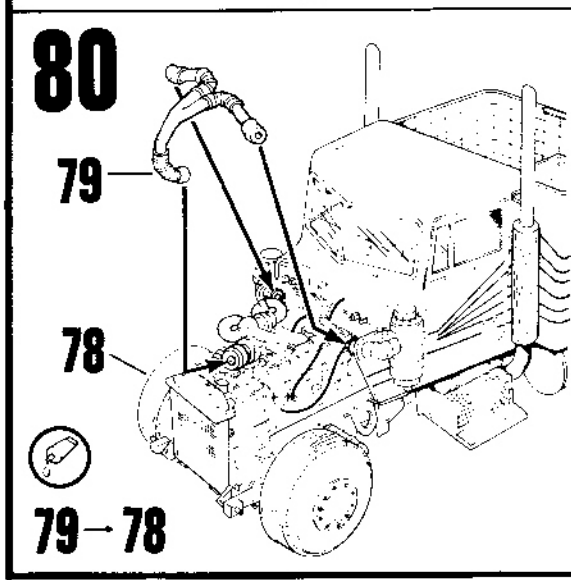
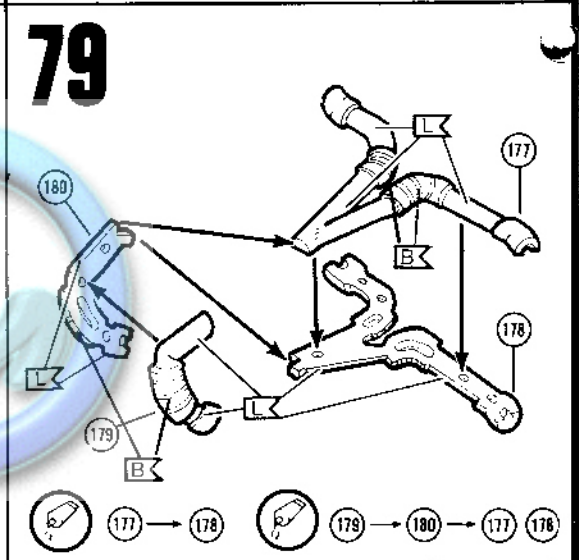
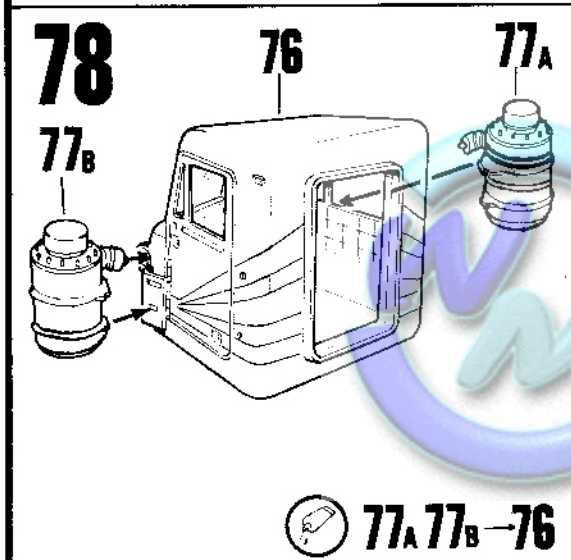
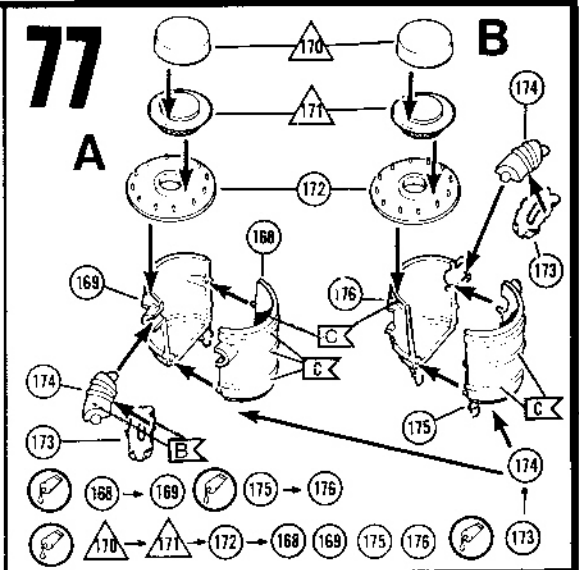
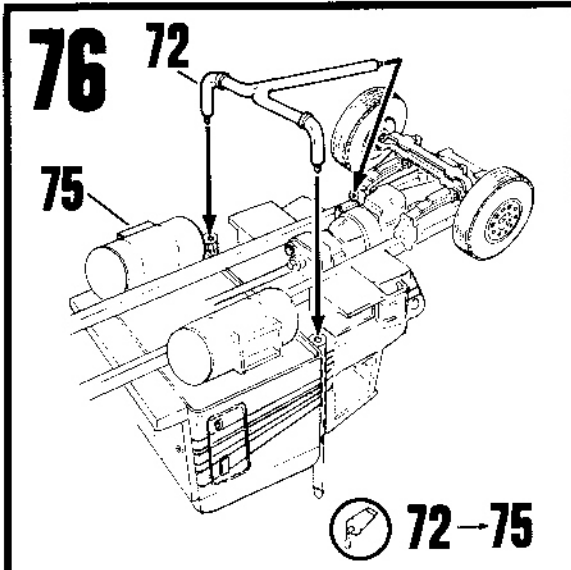

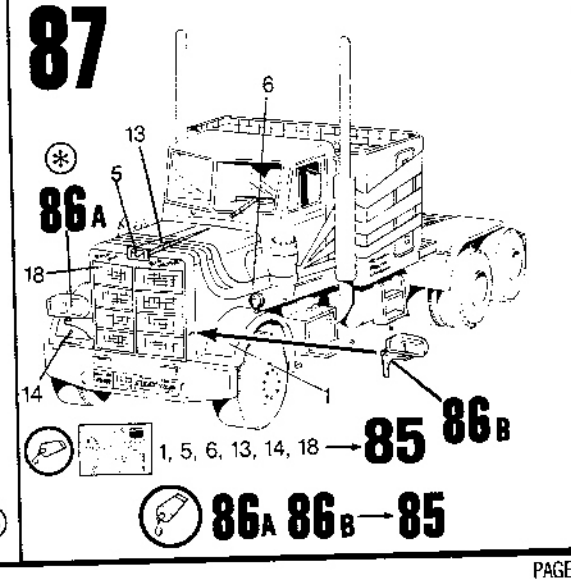
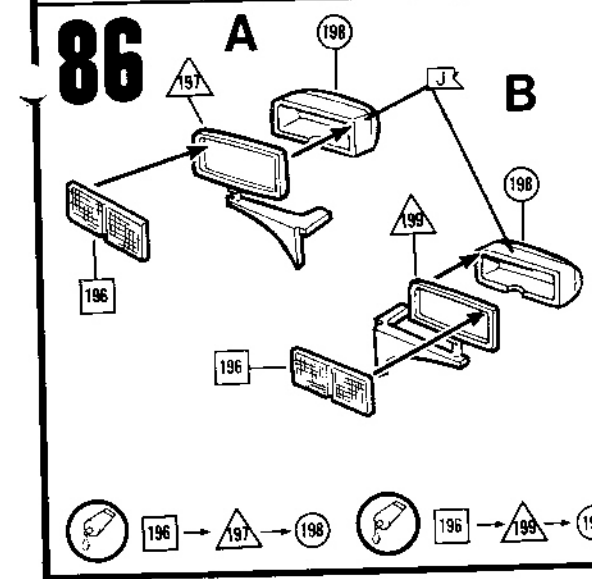
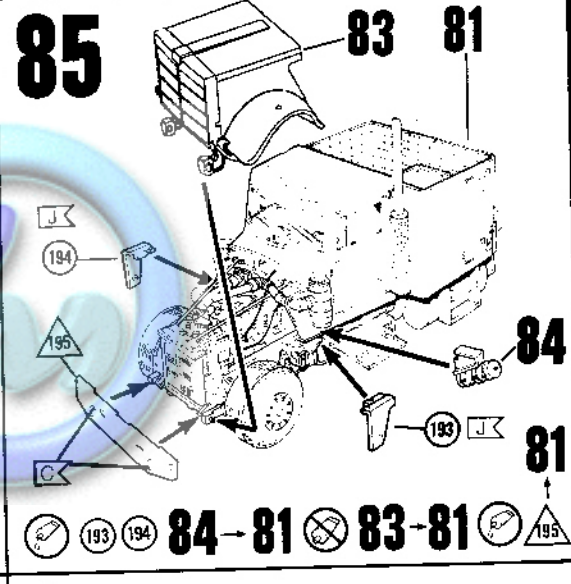
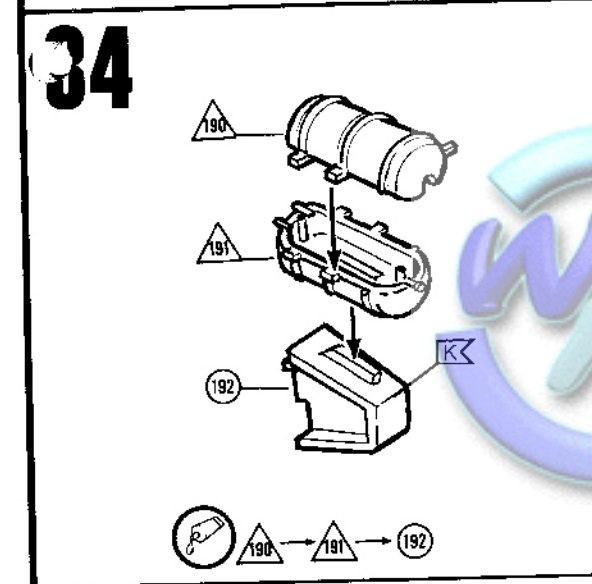
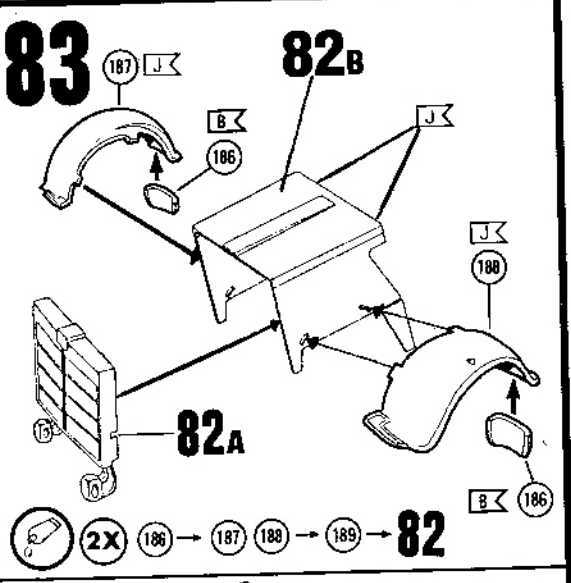
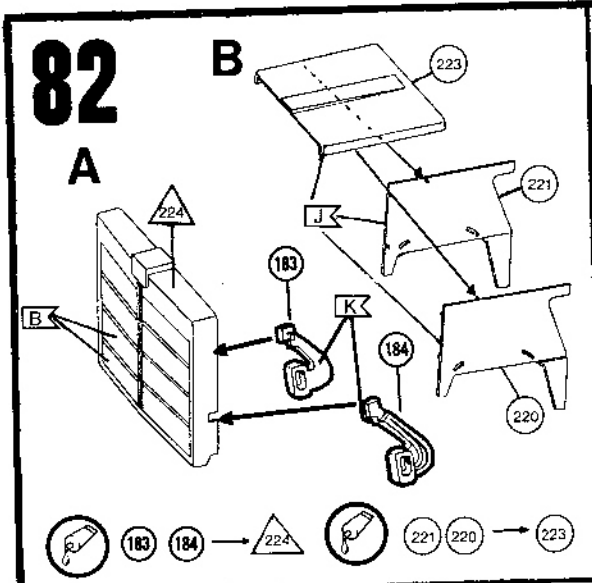

7457

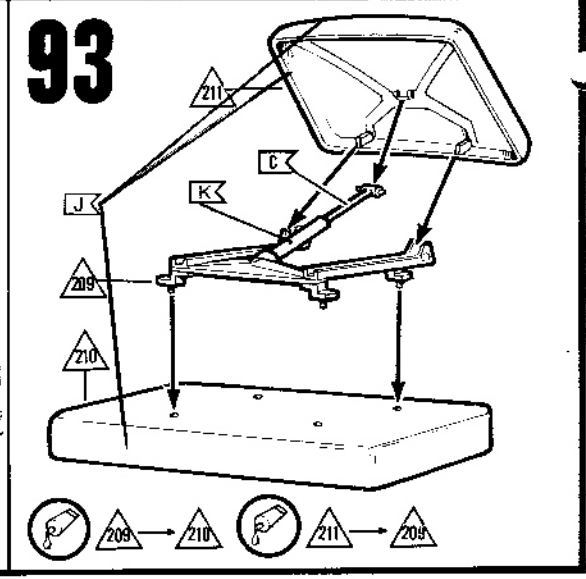
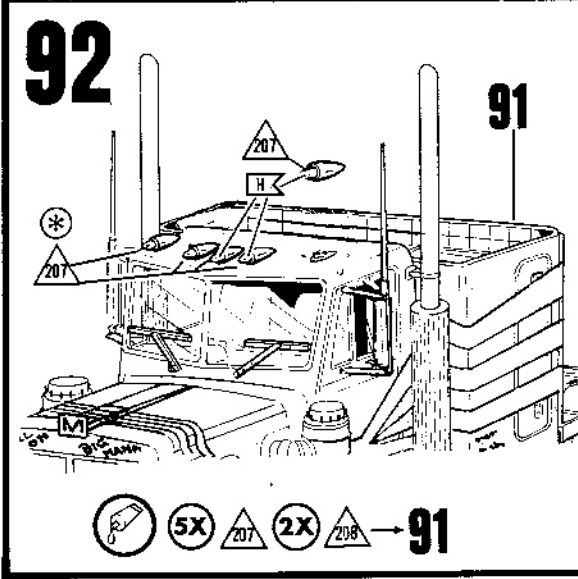
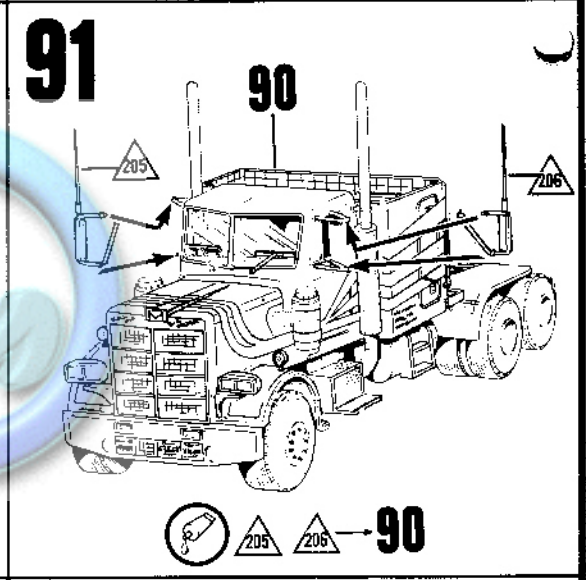
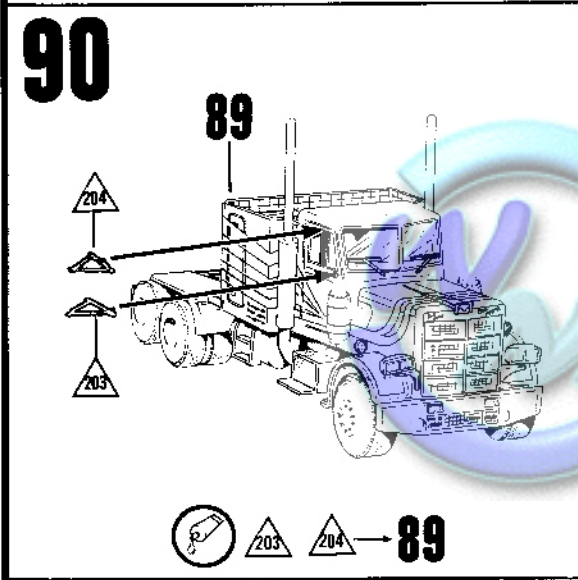
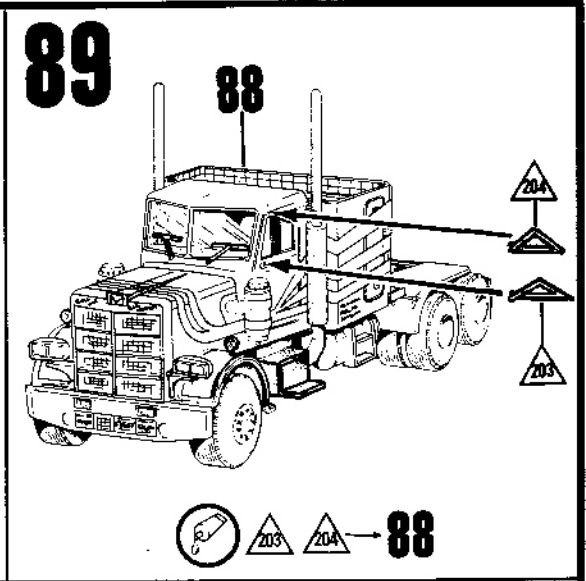
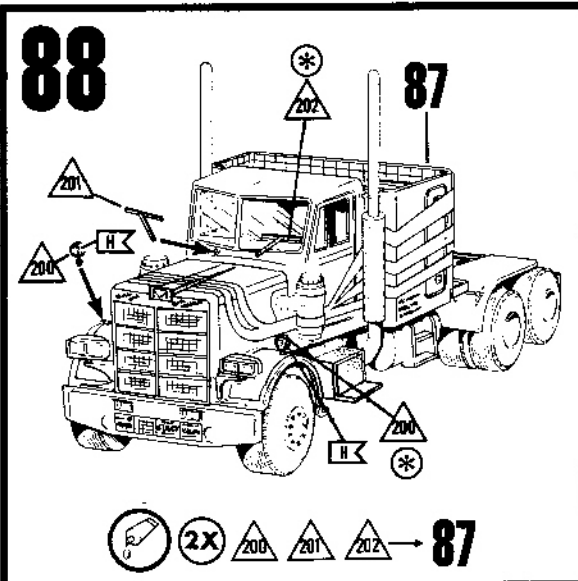

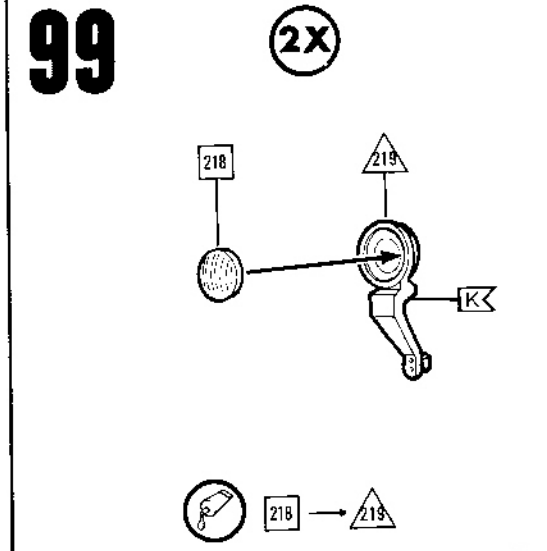
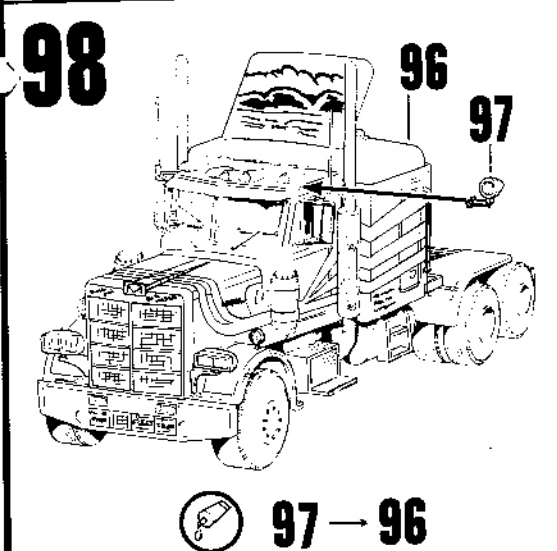
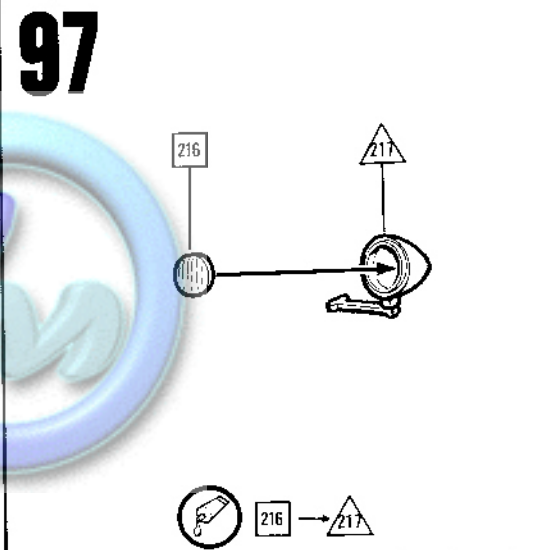
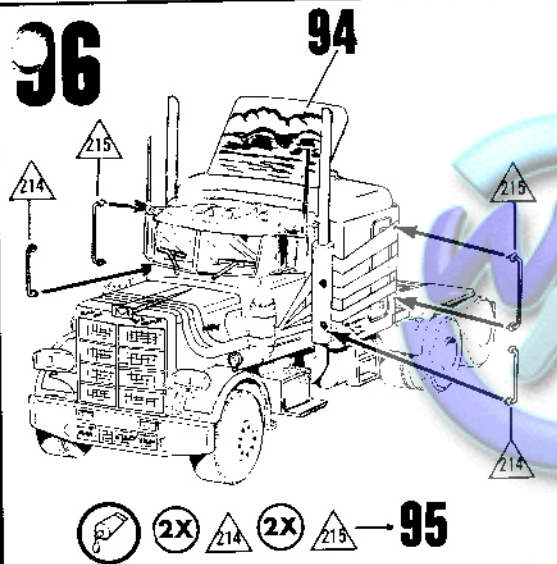
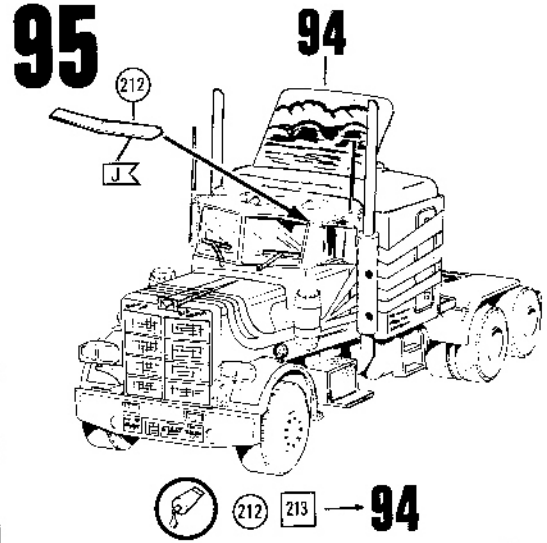
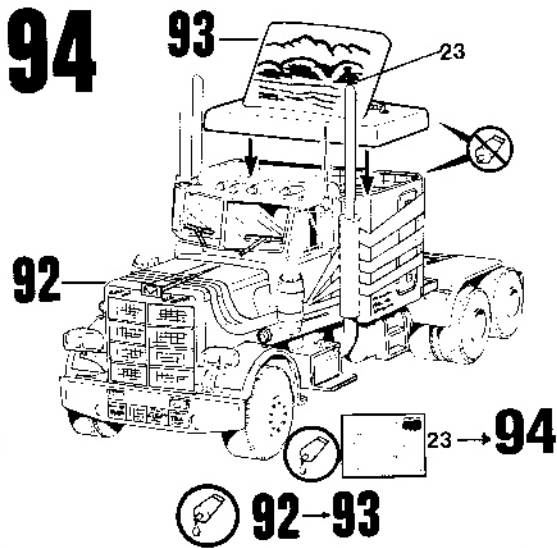

7457

