



Typ 82 Kübelwagen

03073-0389

©2004 BY REVELL GmbH & CO. KG

PRINTED IN GERMANY



Typ 82 Kübelwagen

Der Kübelwagen entstand im Jahre 1938 aus einer Anforderung des Heereswaffenamtes nach einem leichten, geländegängigem Mannschaftsfahrzeug. Das Design stammte aus der Feder von Ferdinand Porsche und war eine Umwandlung des bekannten „Kraft durch Freude“ Wagens (praktisch ein Vorläufer des Käfers). Zwischen 1940 und 1945 wurden etwa 55.000 Fahrzeuge gebaut, von denen nur wenige den 2. Weltkrieg unbeschadet überstanden. Die gute Traktion des heckangetriebenen Fahrzeugs wurde durch ein Zwischengetriebe vor den Hinterrädern erreicht, der Boxermotor leistete 24,5 PS und konnte bis zu 80 km/h erreichen. Bis zu 40% Steigung konnten mit 4 Insassen bewältigt werden, die Wassertiefe betrug 45cm. Das gesamte Fahrzeug wog unbeladen nur 725 kg und bewährte sich auf allen Kriegsschauplätzen.

Typ 82 Kübelwagen

The Kübelwagen was built in 1938 to meet the requirements of the army ordnance office for a light, cross-country personnel-carrier. The design originated from the pen of Ferdinand Porsche and was a version of the well-known "power through pleasure" car (in practice a predecessor of the Beetle). Between 1940 and 1945 about 55,000 of these vehicles were built, just a few of which survived World War II undamaged. The good traction of this rear-wheel-drive vehicle was achieved by means of an intermediate gearbox in front of the rear wheels. The horizontally opposed engine developed 24.5 bhp and could reach a top speed of 80 kph. It was capable of climbing a 40% gradient with 4 occupants and had a fording depth of 45 cm. The total unladen weight of the vehicle was only 725 kg and it proved itself in all theatres of war.

Vor dem Zusammensetzen gut durchlesen!

D: Achtung: Jedes Teil ist nummeriert (1). Reihenfolge der Montageschritte beachten. Benötigte Werkzeuge: Messer und Feile zum Entfernen und Entgraten der Teile (2) Gummiband, Klebeband und Wäscheklammern zum Zusammenhalten der geklebten Einzelteile (3). Plastikteile in einer milden Waschlösung reinigen und an der Luft trocknen, damit der Farbanstrich und die Abziehbilder besser haften. Vor dem Ankleben prüfen ob Teile passen, Klebstoff sparsam auftragen Chrom und Farbe an den Klebeflächen entfernen. Kleine Teile anstreichen, bevor sie vom Rahmen entfernt werden (4) (5). Farben gut durchtrocknen lassen, erst dann den Zusammenbau fortsetzen. Jedes Abziehbildmotiv einzeln auscheiden und ca. 20 Sekunden in warmes Wasser tauchen. Das Motiv an der bezeichneten Stelle vom Papier abschleifen und mit Löschpapier andrücken.

NL: OPGELET: Voor de montage eerst goed de handleiding lezen. Elk onderdeel is genummerd (1). Let op de montagevolgorde. Benodigd gereedschap: mes en vijl voor het afbramen van de onderdelen (2); elastiek, plakband en wasknijpers voor het bij elkaar houden van de gelijmde onderdelen (3). Plastic onderdelen met een zacht afwasmiddel reinigen en vanzelf laten drogen, zodat de verf en de decals beter hechten. Controleer voor het lijmen of de onderdelen passen; lijm dun opbrengen. Chrom en verf van de lijmvlakken verwijderen. Kleine onderdelen verven voordat ze van het raam worden verwijderd (4) (5). Verf goed laten drogen, dan pas verdergaan met de montage. Elke decal afzonderlijk uitsnijden en ca. 20 sec. in warm water dopen. De decal op de aangegeven plaats van het papier schuiven en met vloeipapier andrukken.

GB: ATTENTION: Read the instructions thoroughly prior to assembly. Each component is numbered (1). Adhere to specified sequence of assembly. Tools required: knife and file for removal of components from frame (2); rubber band, adhesive tape and clothes pegs for clamping components together after applying adhesive (3). Clean plastic components in a mild detergent solution and allow to air-dry so that paint and transfers adhere better. Prior to applying adhesive, check to see whether the components fit together; apply adhesive sparingly. Remove chrome and paint from the contact surfaces. Paint small components before removing them from the frame (4) (5). Allow paint to dry well, and only then continue to assemble. Cut out each transfer individually and immerse in warm water for approx. 20 seconds. Slide transfer off paper and into designated position, then press on with blotting paper.

F: ATTENTION: lisez bien la notice de montage avant de commencer. Chaque pièce est numérotée (1). Respectez l'ordre des opérations. Outils nécessaires : couteau et lime pour ébarber les pièces (2); élastiques, ruban adhésif et pinces à linge pour maintenir les pièces collées (3). Nettoyez les pièces en matière plastique dans une solution douce de produit de lavage et faites-les sécher à l'air afin que la peinture et les décalcomanies tiennent mieux. Avant de mettre la colle, vérifiez si les pièces s'adaptent bien les unes aux autres; mettez peu de colle. Enlevez le chrome et la peinture des surfaces de collage. Peignez les petites pièces avant de les détacher de la grappe (4)(5). Laissez bien sécher la peinture avant de poursuivre l'assemblage. Découpez chaque décalcomanie séparément et plongez-la dans de l'eau chaude pendant 20 secondes environ. A l'endroit marqué, faites glisser le motif pour le séparer du papier et pressez-le sur emplacement avec du papier buvard.

E: ¡ATENCIÓN! Antes de comenzar con el ensamblaje, leer detenidamente las instrucciones. Cada pieza va numerada (1). Téngase en cuenta el orden de operaciones del ensamblaje. Herramientas necesarias: Cuchilla y lima para desbarbar las piezas (2). Cintas de goma, cinta adhesiva y pinzas de ropa para sujetar las piezas pegadas (3). Lavar las piezas de plástico en una solución de detergente suave y dejar que se sequen al aire para mejorar así la adhesión de la pintura y de las calcomanías. Antes de aplicar el pegamento comprobar si las piezas quedan correctamente adaptadas. Aplicar el pegamento sin excederse. Alejar de las superficies de pegado el cromado y la pintura. Pintar las piezas pequeñas antes de desprenderlas de su sujeción (4) (5). Antes de proseguir con el ensamblaje, dejar que se seque bien la pintura. Recortar las calcomanías una por una y sumergirlas durante unos 20 segundos en agua caliente. Deslizar del papel la calcomanía en el lugar adecuado y apretarla colocando encima de ella papel secante.

I: ATTENZIONE: Prima dell'assemblaggio leggere attentamente le istruzioni di montaggio. Ogni pezzo è numerato (1). Tener presente la successione delle fasi di assemblaggio. Attrezzi necessari: coltello e lima per togliere la sbavatura dai pezzi (2), nastro adesivo e mollette da bucato per tenere insieme i pezzi singoli dopo averli incollati (3). Lavare i particolari in plastica con un detergente delicato e lasciarli asciugare all'aria, per una migliore adesione dello strato di colore e della figura decalabile. Prima di incollare, verificare che i pezzi si abbinano bene tra di loro; applicare il collante con parsimonia. Togliere cromo e colore dalle superfici da incollare. Dipingere i piccoli accessori sul supporto prima di rimuoverli (4) (5). Far seccare bene la vernice prima di proseguire con l'assemblaggio. Ritagliare singolarmente ogni figura ed immergerla in acqua tiepida per 20 secondi circa. Applicare il motivo nella posizione segnata e tamponarlo con carta assorbente.

S: OBS: Läs instruktionerna noga igenom innan du sätter modellen samman. Vareda detalj är nummerad (1). V g beakta följden i sammansättningsstegen. Verktyg, som du kommer att behöva : kniv och fil för att skrapa detaljerna rena (2), gummiband, tejp och klädnypor för att hålla samman de limmade detaljerna (3). Rengör plastdetaljerna i en mild tvättmedelslösning och torka dem i luften för att lack och dekaler skall hålla bättre. Kolla, om detaljerna passar ihop innan du klistrar dem och använd limmet sparsamt. Avlägsna krom och lack från ytor, som kommer att limmas ihop. Måla de små detaljerna innan du avlägsnar dem från ramen (4) (5). Låt lacket riktigt torka igenom innan du fortsätter med sammansättningen. Skär av varje dekalmotiv enskilt och doppa det i varmt vatten i ca 20 sekunder. Flytta motivet bort från papperet genom att trycka vid det angivna stället och tryck fast med läskpapper.

DK: BEMÆRK: Inden sammensætningen begynder, skal byggevejledningen læses godt igennem. Hver del er nummereret (1). Rækkefølgen af monteringstrinene skal overholdes. Nødvendigt værktøj: Kniv og fil til afgratning af delene (2); gummibånd, tape og tøjklammer til at holde de klæbede (3) enkeltdele sammen. Plastikdelene renses i en mild sæbelud og lufttørres så malingen og overfaringsbillederne bedre kan hæfte. Inden påførelsen kontrolleres om delene passer; limen påføres sparsommeligt. Krom og farve fjernes fra klæbefladerne. De små dele males inden de fjernes fra rammen (4) (5). Lad farven tørre godt inden sammensætningen fortsættes. Overfaringsbilledernes motiver skæres ud enkeltvis og dypes ca. 20 sek. i varmt vand. Skub motivet fra papiret og tryk det fast med trækpapier.

GR: ΠΡΟΣΟΧΗ: Πριν τη συναρμολόγηση, διαβάστε καλά τις οδηγίες. Κάθε εξάρτημα είναι αριθμημένο (1). Προσέξτε τη σειρά "των βημάτων" συναρμολόγησης. Απαιτούμενα εργαλεία: μαχαίρι και λίμα για τη λείανση των εξαρτημάτων (2), λαστίχια, ταινία, κολλητική ταινία και μανταλάκια για τη συγκράτηση των κολλημένων μεμονωμένων εξαρτημάτων (3). Καθαρίστε τα πλαστικά εξαρτήματα μέσα σε ένα "μαλακό" καθαριστικό διάλυμα και στεγνώστε τα στον αέρα, ώστε να υπάρξει καλύτερη πρόσφυση του χρώματος και των χαλκομανιών. Πριν το κόλλημα, ελέγξτε αν ταιριάζουν μεταξύ τους τα εξαρτήματα. Επαλείψτε οικονομικά την κόλλα. Απομακρύνετε από τις επιφάνειες επικόλλησης, χρώμα και βαφή. Βάψτε τα μικρά εξαρτήματα, πριν απομακρυνθούν από το πλαίσιο (4) (5). Αφήστε να στεγνώσουν καλά τα χρώματα και ύστερα συνεχίστε τη συναρμολόγηση. Κόψτε ξεχωριστά το κάθε μοτίβο των χαλκομανιών και βουτήξτε το σε ζεστό νερό για περί. 20 δευτερόλεπτα. Απομακρύνετε το μοτίβο από το χαρτί, στο σηματοδεδειμένο σημείο και πιέστε το με το στουπόχαρτο.

Read before you start!

N: OBS! Les nøye igjennom monteringsanvisningen før sammenbyggingen. Hver del er nummerert (1). Folg rekkefølgen på monteringstrinene. Nødvendig verktoy: Kniv og fil for fjerning av grader på delene (2), gummibånd, tape og klesklyper for å holde sammen de limede enkeltdelene (3). Rengjør plastdelene i mildt såpevann og la dem lufttørke, slik at fargen og bildene sitter bedre. Før pålimingen må det kontrolleres om delene passer: Ta på litt lim. Fjern krom og farge på klæbeflatene. Mal de små delene før de fjernes fra rammen (4) (5). La fargene tørke godt før sammenbyggingen fortsettes. Skjær ut hvert av motivene for seg og legg dem i varmt vann i ca. 20 sekunder. Skyv motivet fra papiret på det merkede stedet og trykk på med trekkpapier.

P: ATENÇÃO: Antes de iniciar a montagem leia atentamente o manual de construção. Todas as partes componentes são numeradas (1). Atenção para a sequência das etapas de montagem. Ferramentas necessárias: Faca e lixa para aparar a rebaba das peças (2), elástico, fita adesiva e molas de roupa para sustentar as peças (3) durante a colagem. As peças de plástico devem ser limpas numa solução fraca de detergente e secas ao ar, de forma que a demão de tinta e os decalques tenham uma boa adesão. Antes de cola, verificar se as peças encaixam; utilizar a cola em pequena quantidade. Eliminar o cromado e a tinta das superfícies a serem coladas. Não passar cola nas peças que ainda se encontram fixas na grade de matéria plástica. Pintar as peças pequenas antes de retirá-las da grade (4) (5). Deixar a tinta secar completamente para depois continuar com a montagem. Cortar separadamente cada um dos decalques e mergulhá-los em água morna durante aproximadamente 20 segundos. Decalar os motivos do papel na posição indicada e secar com mata-borrão.

FIN: HUOMIO: Lue rakennusohjeet huolellisesti ennen kokoontamista. Jokainen osa on numeroitu (1). Huomioi osien oikea asennusjärjestys. Tarvitavat työkalut: Veitsi ja viila osien ylimääräisten pursetien poistamiseen (2); kuminauha, teippiä ja pyykkipoikia yhteensidontaan osien paikkaamattomiksi (3). Puhdista muoviosat miedolla pesuaineliuoksella jotta anna niiden kuivua itsestään, jotta maali ja siirtokuvat tarttuvat niihin paremmin. Tarkasta ennen liimausta, että osat sopivat toisiinsa; levitä liimaa säästeliäästi. Poista kromaus ja maali liimainnoista. Maalaa pienet osat ennen kuin irrotat ne pidinraameista (4) (5). Anna maalin kuivua kunnolla ennen kuin jatkat kokoontamista. Leikkaa jokainen siirtokuva erikseen irri ja upota lämpimään veteen n. 20 sekunniksi. Irrota kuvio paperiin merkitystä kohdasta samalla painamalla imupaperi kuvion toista puolta vasten.

RUS: Внимание: Перед сборкой хорошо прочитайте руководство по монтажу. Каждая деталь пронумерована (1). Соблюдать последовательность монтажа. Необходимые рабочие инструменты: нож и напильник для зачистки деталей (2); резиновая лента, клейкая лента и зажимы для сушки белья для прижимания склеиваемых отдельных деталей (3). Детали из пластика очистить в растворе мягкого моющего средства и высушить на воздухе для того, чтобы краска и переводные картинки лучше прилипали. Перед приклеиванием проверить, подходят ли детали; клей наносить экономно. Хром и краску удалить с поверхности склеивания. Небольшие детали покрасить перед тем, как они будут удалены из рамки (4) (5). Краску необходимо хорошо просушить, только после этого продолжать сборку. Каждую соответствующую переводную картинку отдельно вырезать и примерно на 20 секунд окунуть в теплую воду. На обозначенном месте картинку отделить от бумаги и прижать промокающей бумагой.

PL: UWAGA: Przed składaniem przeczytać dokładnie instrukcję montażu. Każda część jest ponumerowana (1). Zwrócić uwagę na kolejność przeprowadzania poszczególnych punktów montażowych. Potrzebne narzędzia: nóż oraz pilnik do usunięcia zadziórów z poszczególnych elementów (2); taśma gumowa, taśma klejąca, klamki do bielizny dla przytrzymania sklejonnych elementów (3). Wymyć plastikowe części w wodzie z delikatnym środkiem myjącym oraz osuszyć na powietrzu, aby zapewnić lepszą przylepność farby oraz kalkomanii. Sprawdzić przed przyklejeniem, czy dane elementy pasują do siebie; nanosić klej oszczędnie. Usunąć chrom oraz farbę z powierzchni przeznaczonych do klejenia. Małe elementy pomalować jeszcze przed wycięciem z ramki (4) (5). Farbę dobrze wysuszyć, dopiero potem kontynuować składanie części. Wyciąć pojedynczo każdy z motywów kalkomanii i zanurzyć na 20 sekund w ciepłej wodzie. Ściągnąć motyw z papieru na oznaczone miejsce i docisnąć bibułą.

TR: DİKKAT: Birleştirmeden önce montaj talimatını iyice okuyun. Her parça numaralandırılmıştır (1). Montaj adimları sırasına dikkat edin. Gerekli takımlar: Parçaların çapaklarını almak için bıçak ve eğe (2); lastik bant, yapıştırıcı parçaları bir arada tutmak için yapıştırma bandı ve çamaşır mandalı (3). Plastik parçaları yumuşatmak bir deterjan ile temizleyin, boya ve çıkartmaların daha iyi yapışması için, açık havada kurutun. Yapıştırmadan önce parçaların uyup uymadığını kontrol edin; yapışkanı idareli bir şekilde sürün. Krom ve boyayı yapıştırma yüzeylerinden temizleyin. İskeletten sökmöden önce, küçük parçaları boyayın (4) (5). Boyayı iyice kurumaya bırakın, sonra montaja devam edin. Her çıkartma motifini tek tek kesin ve yaklaşık 20 saniye sıcak suya daldırın. Motifi işaretlenen yere kağıttan itin ve silme kağıdı ile bastırın.

CZ: POZOR: Před sestavením montážního návodu důkladně pročíst. Každý díl je očíslovan (1). Dbejte na pořadí montážních kroků. Potřebné nástroje: Nůž a pilník k odstranění výronků na dílech (2); pryžová páska, lepidlo páska a količky na prádlo pro přidržování lepených jednotlivých dílů (3). Díly z plastické hmoty vyčistit v roztoku jemného pracího prostředku a nechat vyschnout na vzduchu, za účelem zajištění lepší přilnavosti barevného nátěru a obtisků. Před nalepením zkontrolovat, zdali díly ležící; lepidlo nanášet úsporně. Chrást a barvu na lepených plochách odstranit. Malé díly natřít před jejich odstraněním z rámu (4) (5). Barvy nechat dobře proschnout, teprve potom pokračovat v sestavení. Každý motiv obtisku jednotlivě vyřiznout a ponořit do teplé vody na dobu přibližně 20 sekund. Motiv na označeném místě z papíru odsunout a přitlačit pomocí stíračů papíru.

H: FIGYELEM: Az összeállítás előtt az építési útmutatót alaposan át kell olvasni. Minden alkatrész számmal látatik el (1). A szerelési lépések sorrendjére ügyelni kell. Szükséges szerszámok: kés és reszelő az alkatrészek sorjatlánításához (2); gumiszalag, ragasztószalag és ruhacsipesz az összeragasztott alkatrészek megtartásához (3). A műanyag alkatrészeket lágy mosószeres oldatban kell tisztítani és a levegőn kell megszáritani, hogy a festékbevonat és a matricák jobban tapadjanak. A felragasztás előtt ellenőrizni kell, hogy az alkatrészek összeillenek-e; a ragasztóanyagot takarékosan kell felhordani. A kromot és festéket a ragasztási felületekről el kell távolítani. A kisméretű alkatrészeket a keretből történő eltávolítás előtt be kell festeni (4) (5). A festékeket hagyni kell jól megszáradni, az összeszerelést csak ezután szabad folytatni. Minden matrica-motívumot egyesével kell kivágni és kb. 20 másodpercre meleg vízbe kell áztatni. A motívumot a megjelölt helyen a papírról lecsúsztatni és itatóspapírral felnyomni.

SLO: UPOZORILO: pred sestavo dobro prečitati upozorilo za sestavo. Vsaki del je označen (1). Slediti sled postopka pri montiranju. Potrebno orodje: noži in orodje za delitev delov (2), gumijaste trake, traka z lepilom in klucke za učvrstilo zalepenih delov (3). Plastične dele očistiti z blagim deterdžentom, sižiti na zraku da bi se sloji barve in preslikači boljše prijeli. Pre lepljenje obvetno preveriti če se deli uklapajo eden v drugi. Počasi nanašati lepilo. Na površinah na katere nanašamo lepilo treba prvo odstraniti hrom in barvo. Manjše dele prvo treba premazati in pšotem oddeliti z rama (4) (5). Pustiti da se barve dobro posušijo, in šele potem nastaviti v sestavljanju. Vsaki preslikač posebno preveriti in potopiti v toplo vodo ca. 20 sekund. Motiv na odrejenem mestu oddeliti od papirja in nanesti z upijačem.

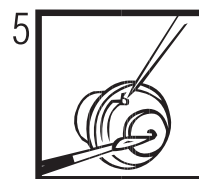
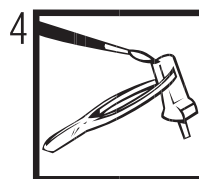
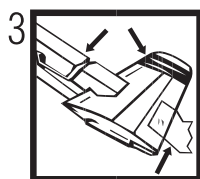
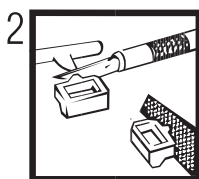
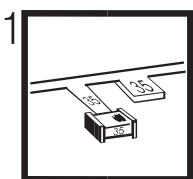

03073

Benötigte Farben / Used ColorsBenötigte Farben
Required coloursPeintures nécessaires
Benodigde kleurenPinturas necesarias
Tintas necessáriasColori necessari
Använda färgerTarvittavat värit
Du trenger følgende fargerNodvendige farger
Необходимые краскиPotrzebne kolory
Απαιτούμενα χρώματαGerekli renkler
Potřebné barvySzükséges színek
Potrebne barve**A**

sand, matt 16
sandy yellow, matt
couleur de sable, mat
zandkleur, mat
arena, mate
areia, fosco
sabbia, opaco
sand, matt
hiekkä, himmeä
sand, matt
sand, matt
песчаный, матовый
piaskowy, matowy
χρώμα άμμου, ματ
kum rengi, mat
písková, matná
homokszínű, matt
pesek, mat

B

panzergrau, matt 78
tank grey, matt
gris blindé, mat
pantsergrjjs, mat
plomizo, mate
cinzento militar, fosco
color carro armato, opaco
pansargrá, matt
panssarinharmaa, himmeä
kampvogngrå, mat
panssergrå, matt
серый танк, матовый
szary czołg., matowy
γκρι τανκς, ματ
panzer grisi, mat
pancéřové šedá, matná
páncéřszürke, matt
oklopno siva, mat

C

seeegrün, matt 48
sea green, matt
vert d'eau, mat
zeegroen, mat
verde mar, mate
verde lago, opaco
havsgrön, matt
merenvihreä, himmeä
havgrön, mat
sjögrön, matt
зеленый морской, матовый
zieleń morską, matowy
πράσινο λίμνης, ματ
göl yeşili, mat
mořská zelená, matná
tengerzöld, matt
morsko zelena, mat

D

weiß, matt 5
white, matt
blanc, mat
wit, mat
blanco, mate
branco, fosco
bianco, opaco
vit, matt
valkoinen, himmeä
hvid, mat
hvit, matt
белый, матовый
biały, matowy
λευκό, ματ
beyaz, mat
bilá, matná
fehér, mat
bela, mat

E

anthrazit, matt 9
anthracite grey, matt
anthracite, mat
antraciet, mat
antracita, mate
antracite, fosco
antracit, opaco
vit, matt
antrasiitti, himmeä
koksgrå, mat
antrasitt, matt
антрацит, матовый
antracyt, matowy
ανθρακί, ματ
antrasit, mat
antracit, matná
antracit, matt
tamno siva, mat

F

eisen, metallic 91
steel, metallic
coloris fer, métallique
ijzerkleurig, metallic
ferroso, metalizado
ferro, metallico
järnfärg, metallic
teräksenvärinen, metallikiito
jern, metallik
jern, metallic
stalnoy, metallik
železo, metaliczny
σιδηρού, μεταλλικό
demir, metallik
železná, metaliza
vas, metáll
železna, metallik

G

lederbraun, matt 84
leather brown, matt
brun cuir, mat
lederbruin, mat
marrón cuero, mate
castanho couro, fosco
marrone cuoio, opaco
läderbrun, matt
nahkanruskea, himmeä
läderbrun, mat
larbrun, matt
коричневая кожа, матовый
brunatny jak skóra, matowy
καφέ δερματος, ματ
deri kahverengi, mat
koženě hnědá, matná
börbarna, matt
koža rjava, mat

H

silber, metallic 90
silver, metallic
argent, métallique
zilver, metallic
plata, metalizado
grata, metálico
argento, metallico
silver, metallic
hopea, metallikiito
sølv, metallik
sølv, metallic
серебристый, металлнк
srebro, metaliczny
ασημί, μεταλλικό
gümüş, metallik
stříbrná, metaliza
ezüst, metáll
srebrna, metallik

I

rost, matt 83
rust, matt
rouille, mat
roest, mat
orin, mate
ferugem, fosco
color ruggine, opaco
rost, matt
ruoste, himmeä
rust, matt
rust, matt
ржавчина, матовый
rdzawy, matowy
χρώμα οκουριάς, ματ
pas rengi, mat
rezavá, matná
rozsdá, matt
rjava, mat

J

karmínrot, matt 36
carmin red, matt
rouge carmin, mat
karmijnrood, mat
carmin, mate
vermelho carmin, fosco
rosso carminio, opaco
karmínröd, matt
karmiinpunainen, himmeä
karmínröd, mat
karmínröd, matt
красный кармин, матовый
karmínowy, matowy
κόκκινο δαϊρήδο, ματ
lái rengi, mat
krbově červená, matná
kárminpiros, matt
šmínka rdeča, mat

K

staubgrau, matt 77
dust grey, matt
gris poussière, mat
stofgrjjs, mat
ceniciento, mate
cinzento de pó, fosco
grigio sabbia, opaco
dammgrå, matt
pölynharmaa, himmeä
stovgrå, mat
stovgrå, matt
серый пыльный, матовый
szary kurz, matowy
χρώμα σκόνης, ματ
toz grisi, mat
prachově šedá, matná
porszürke, matt
prah siva, mat



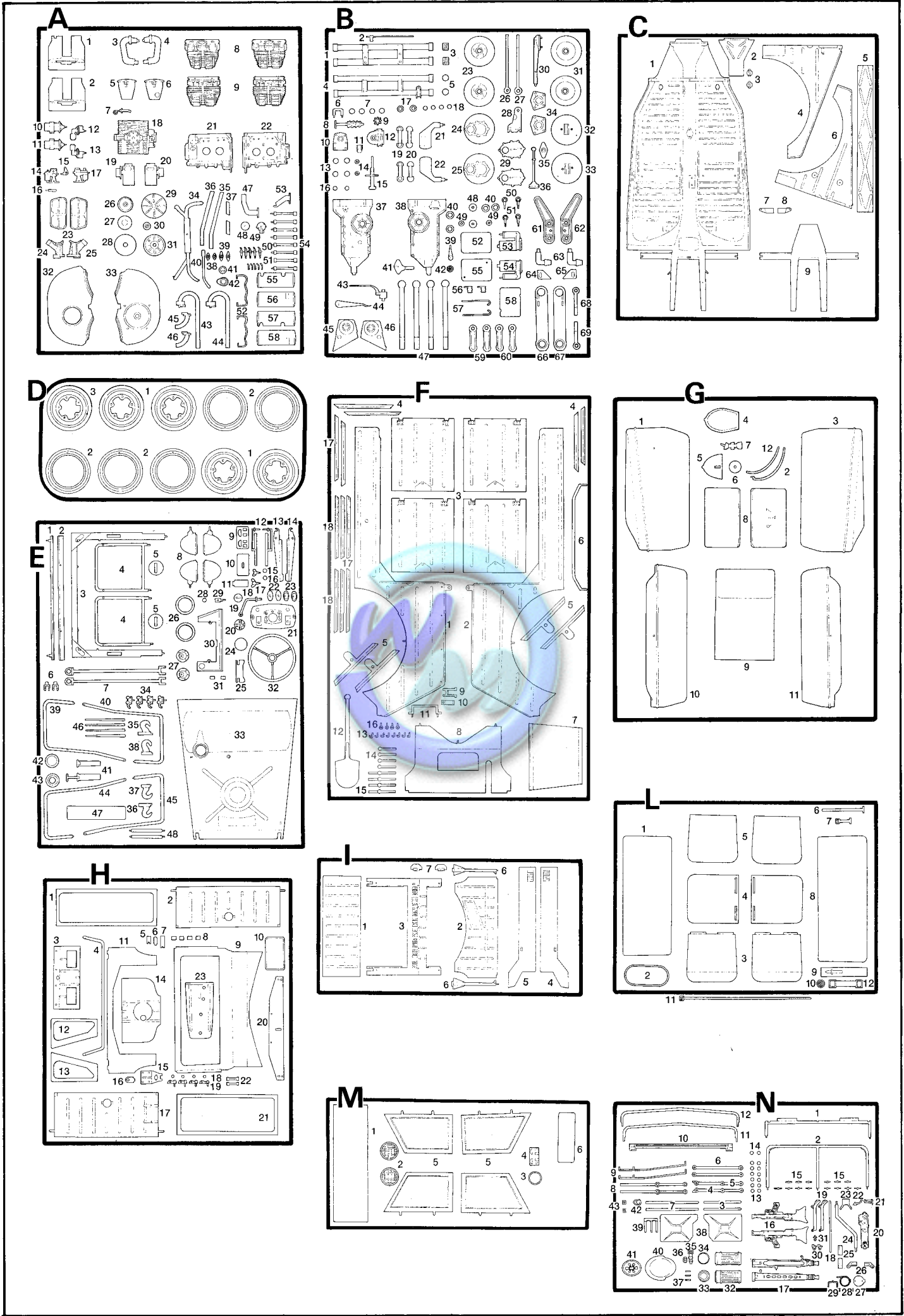

03073

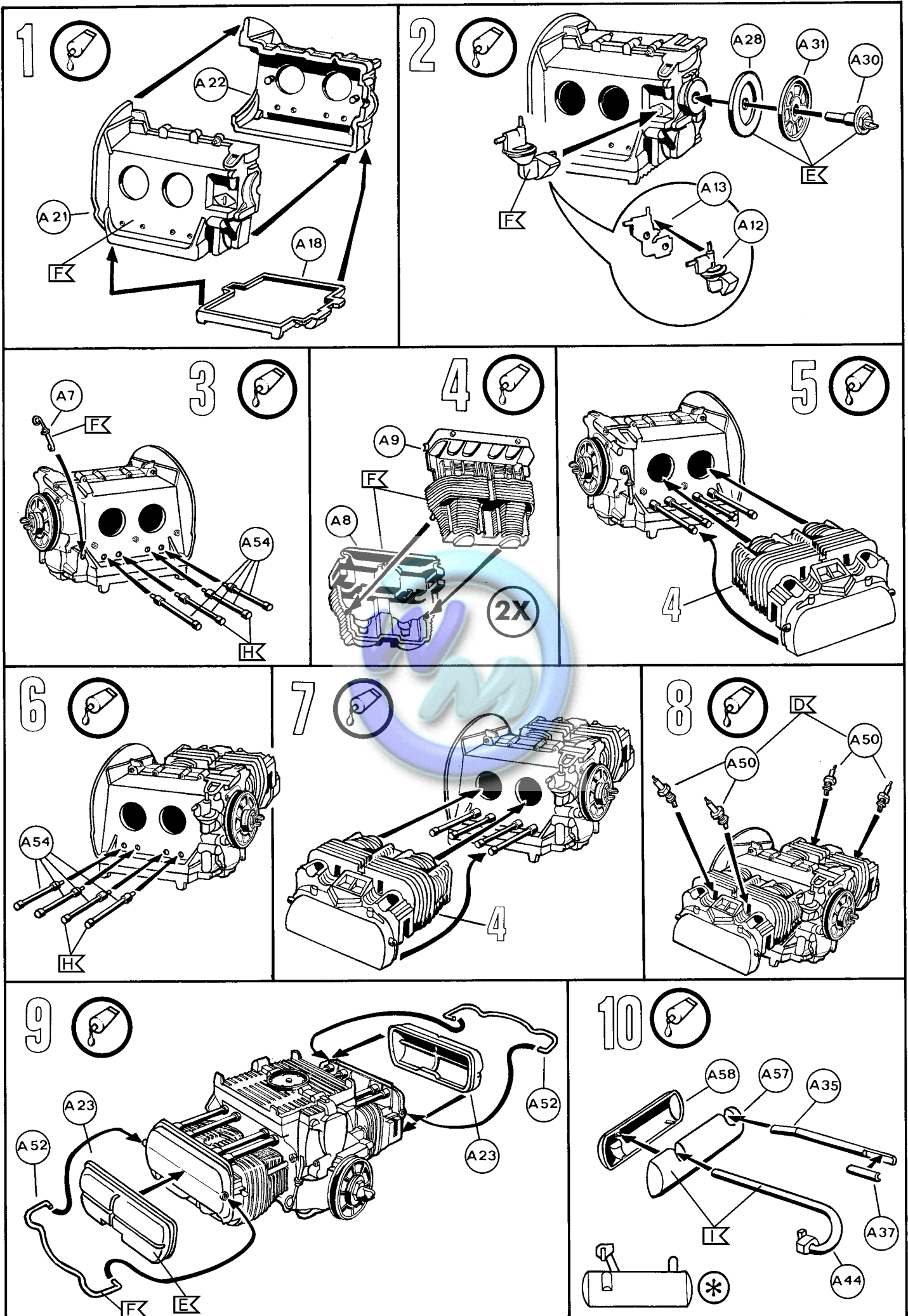

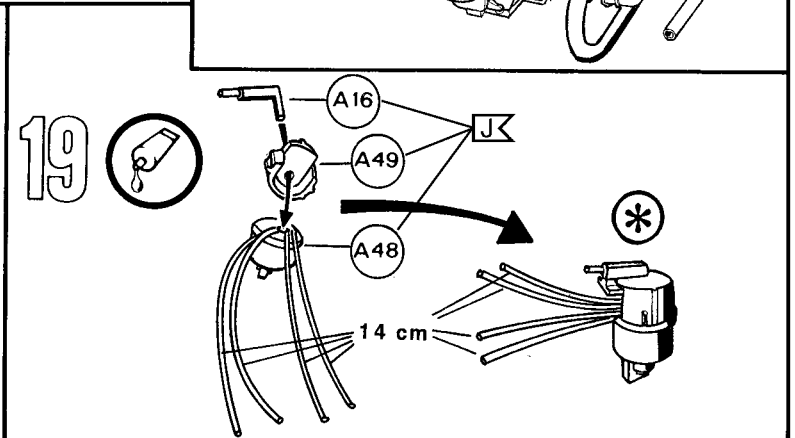
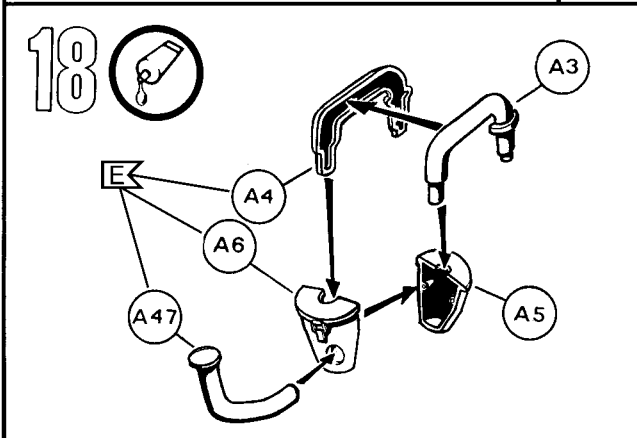
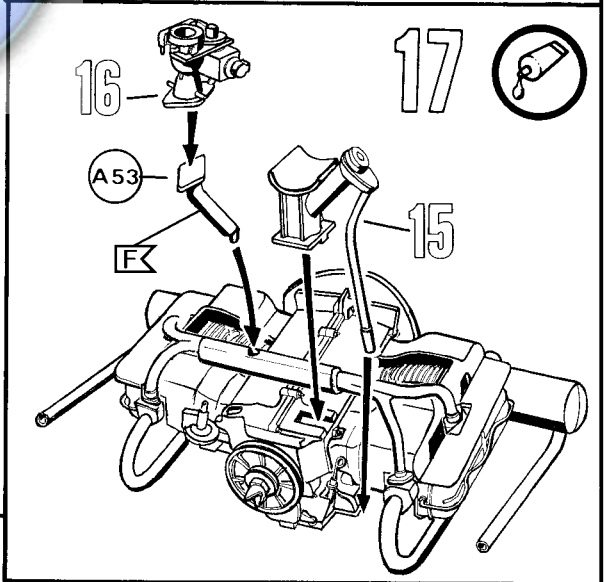
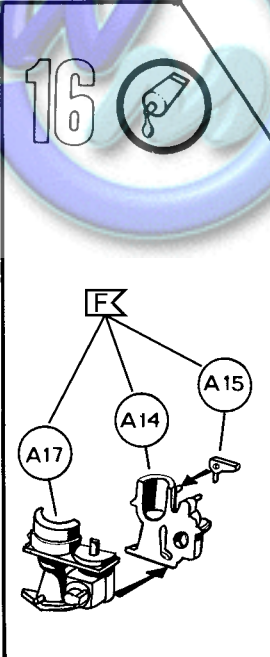
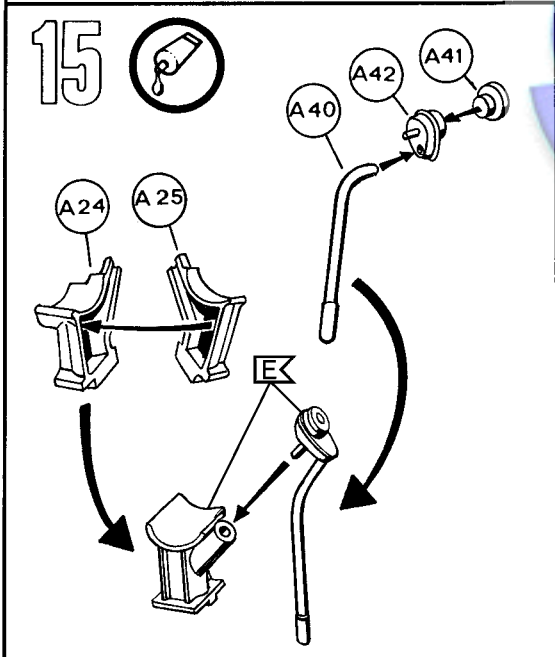
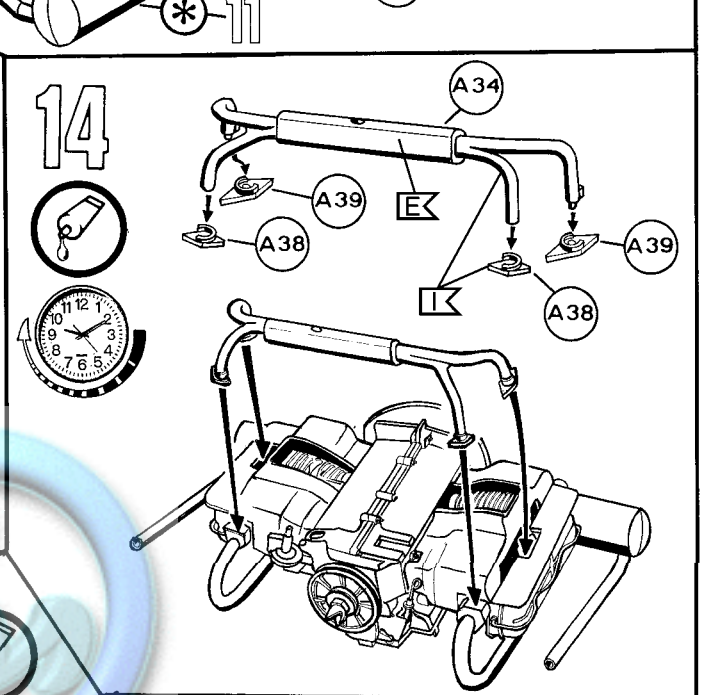
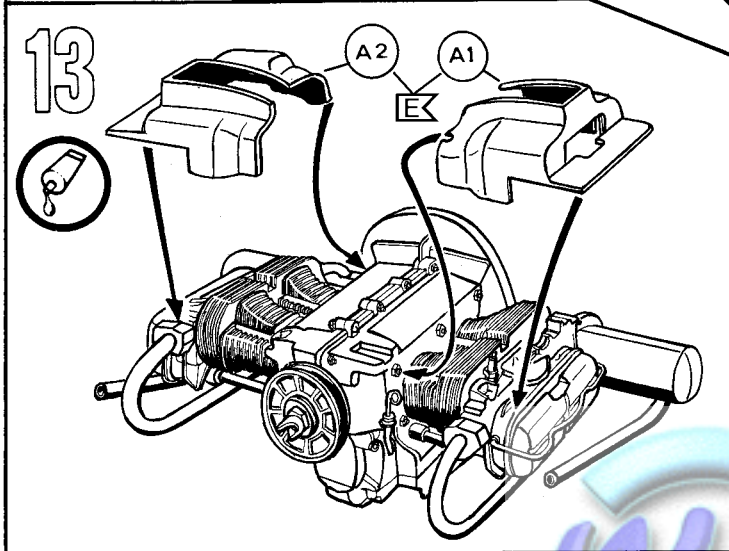
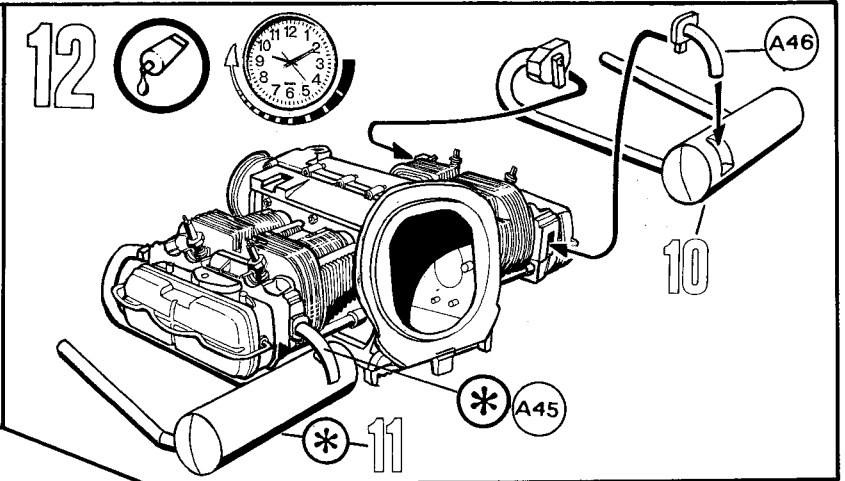
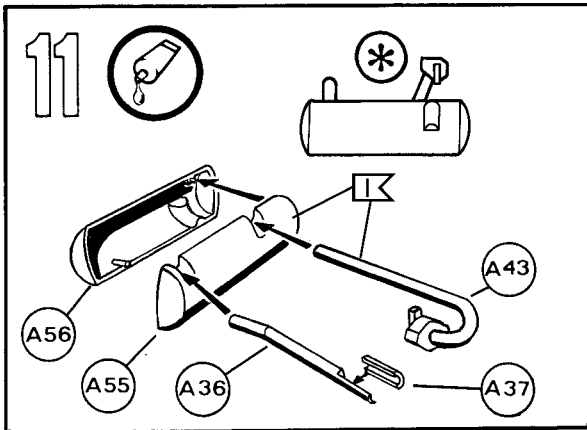

03073

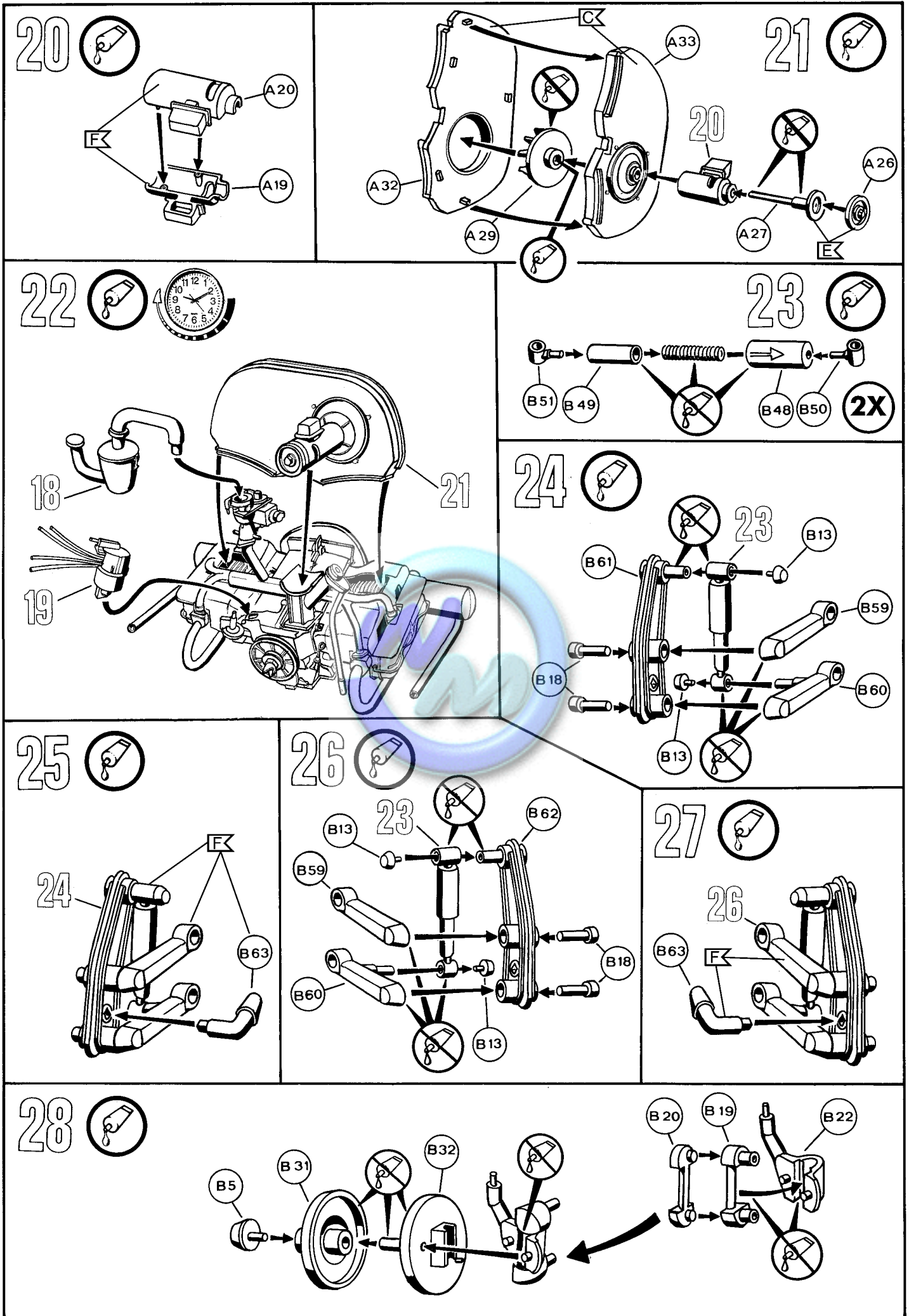

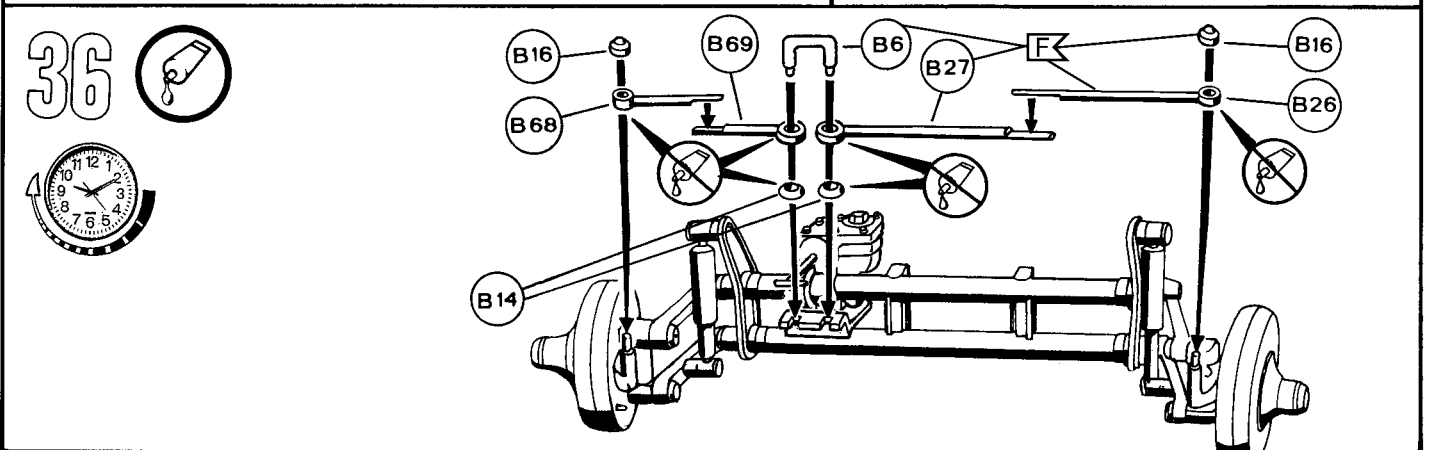
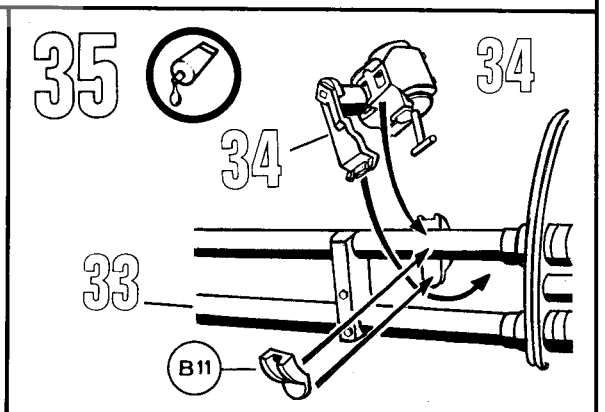
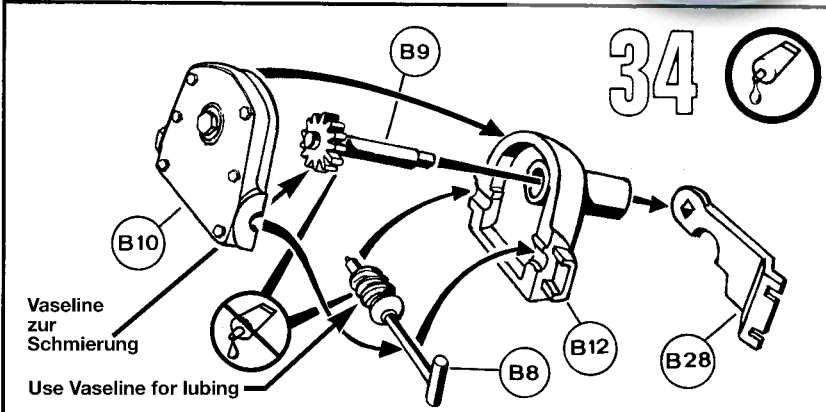
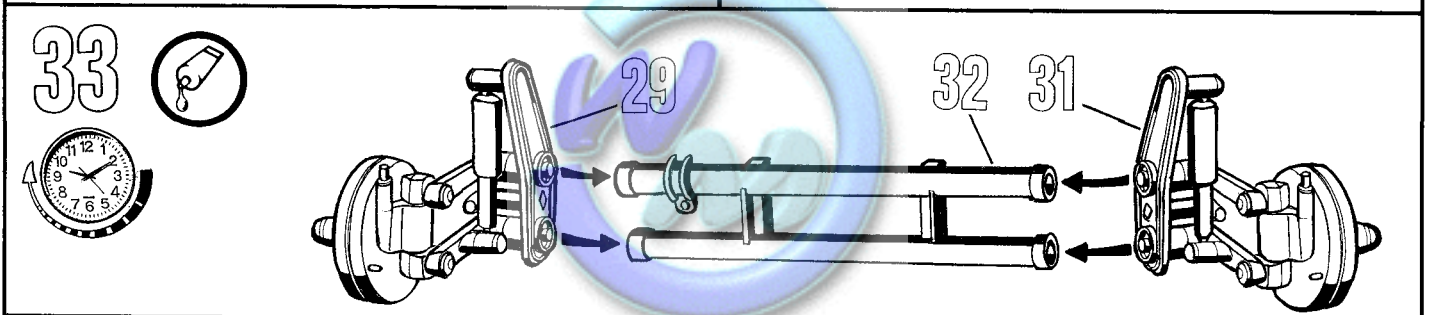
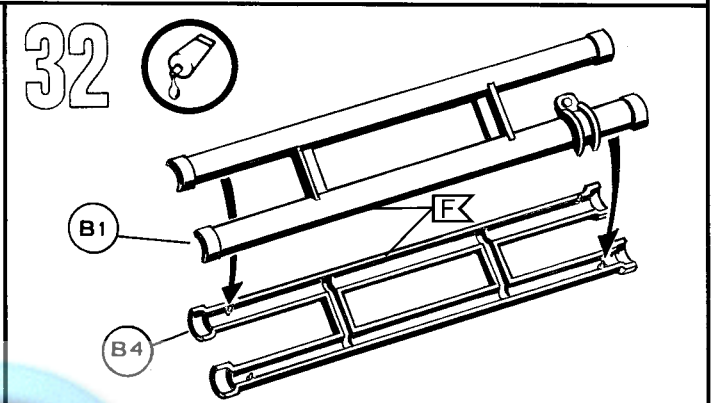
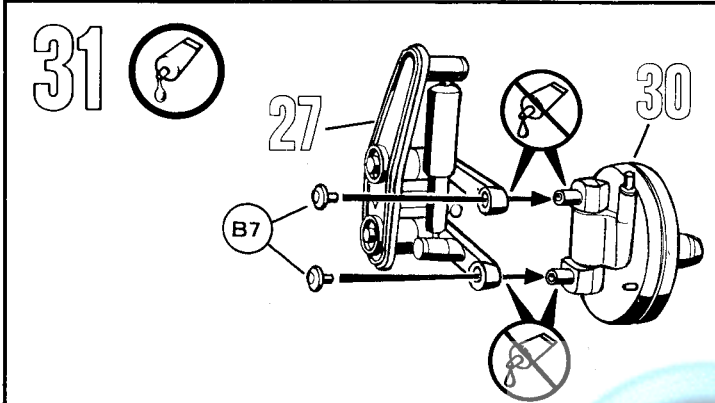
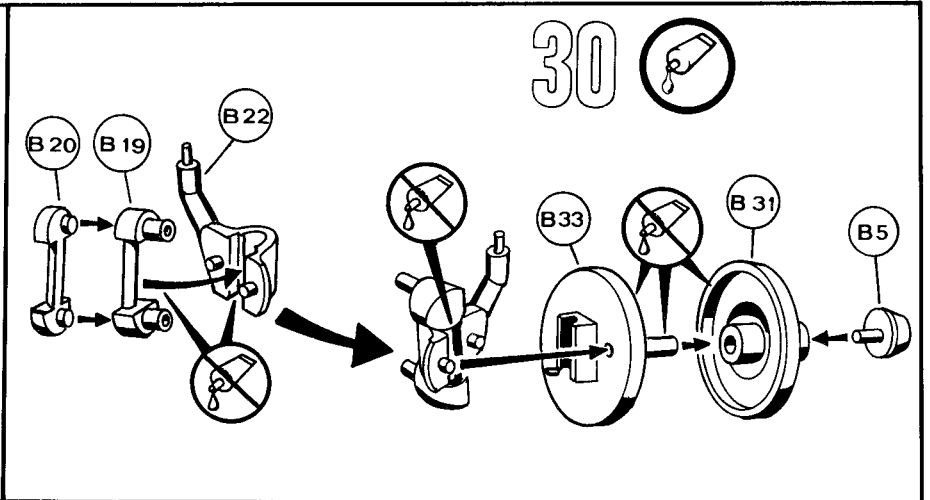
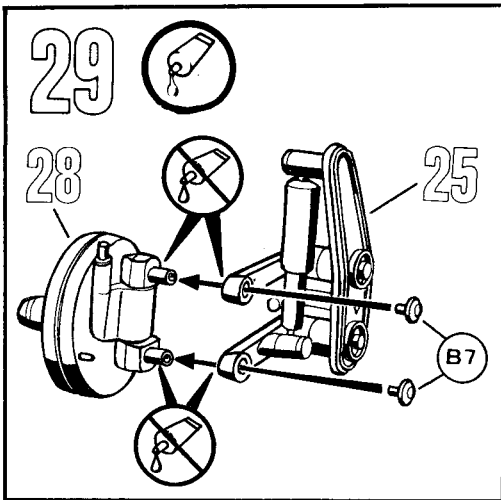

03073

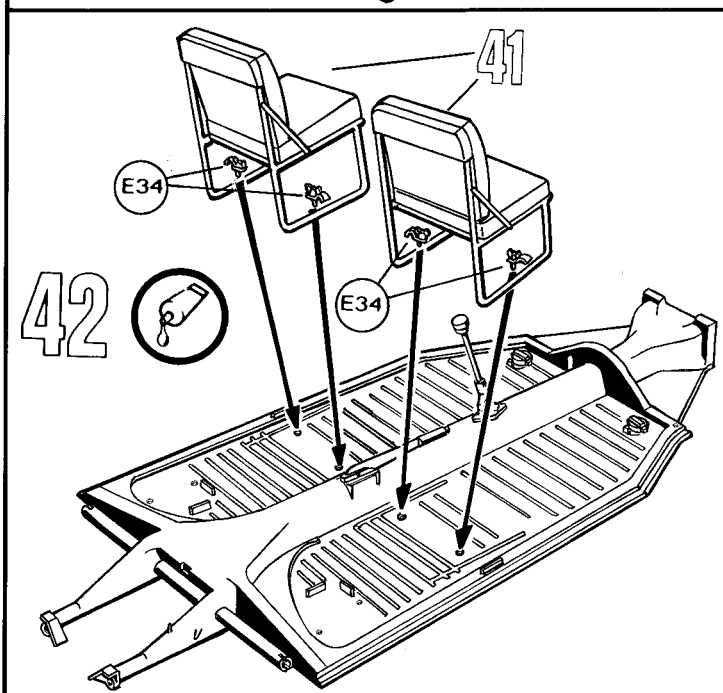
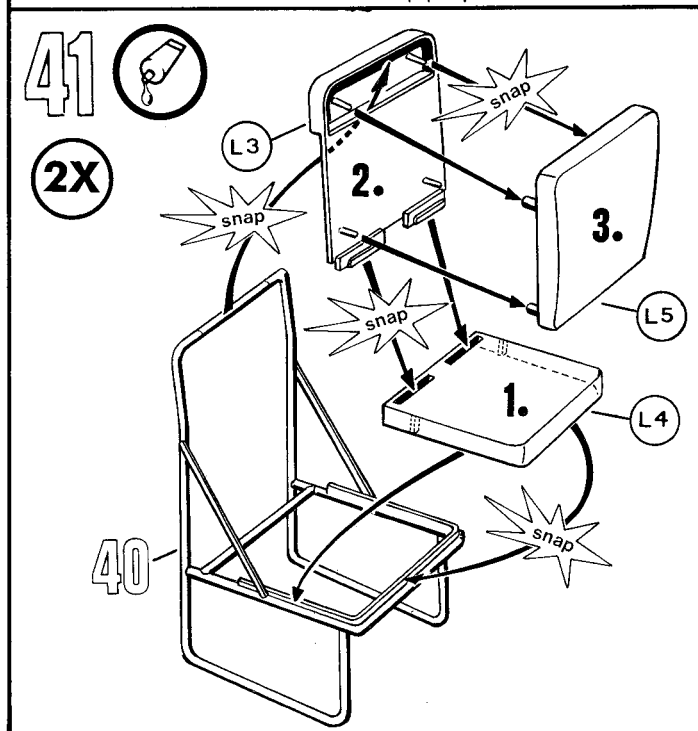
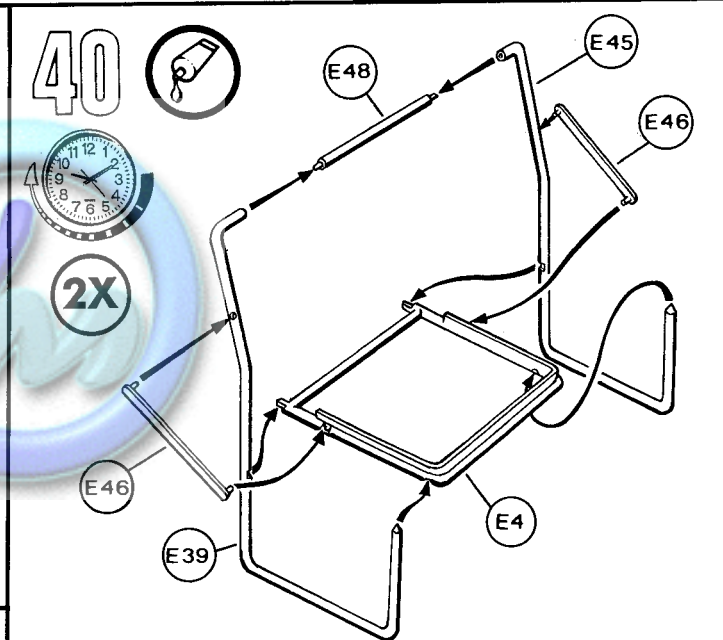
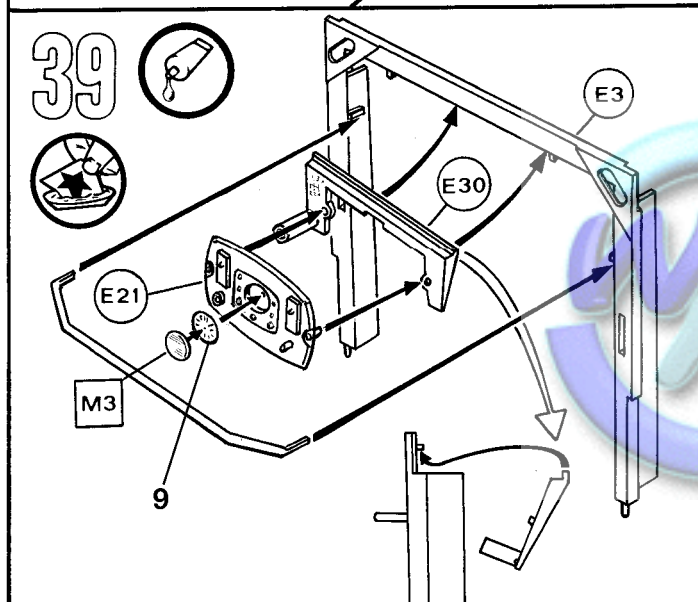
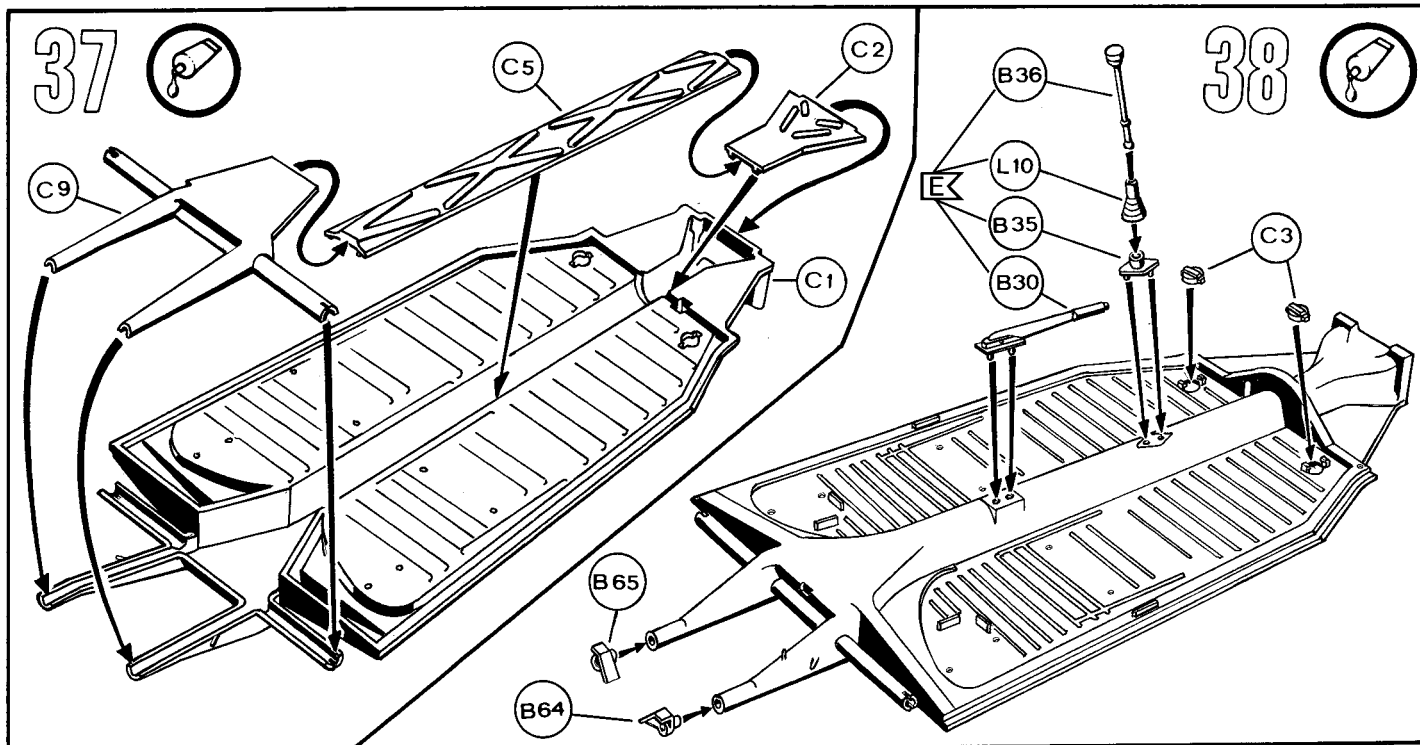

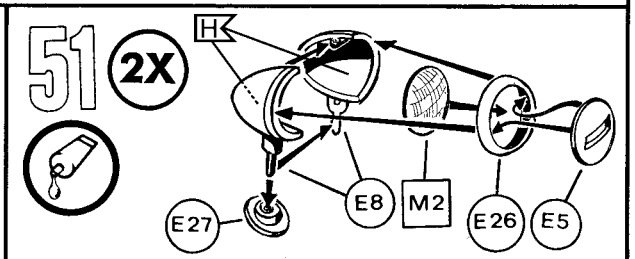
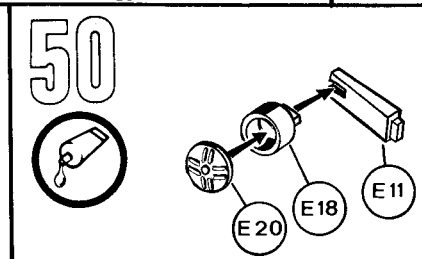
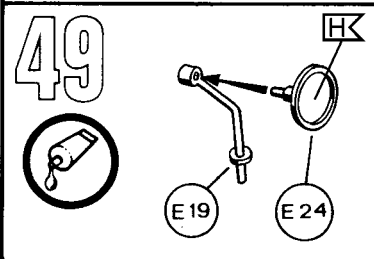
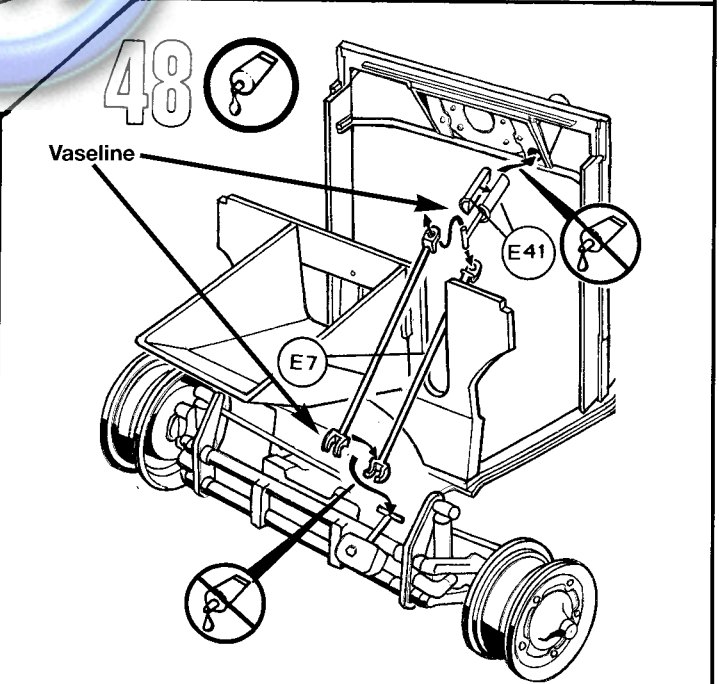
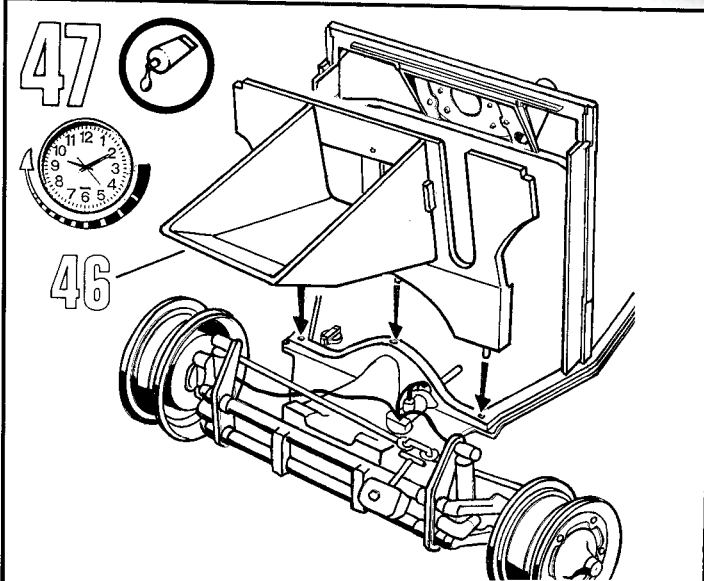
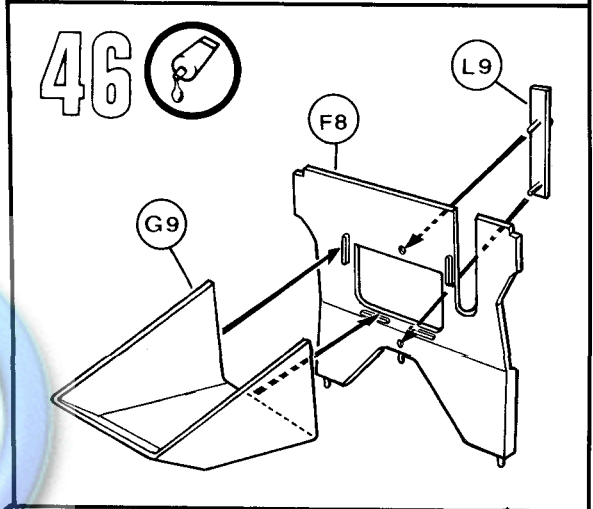
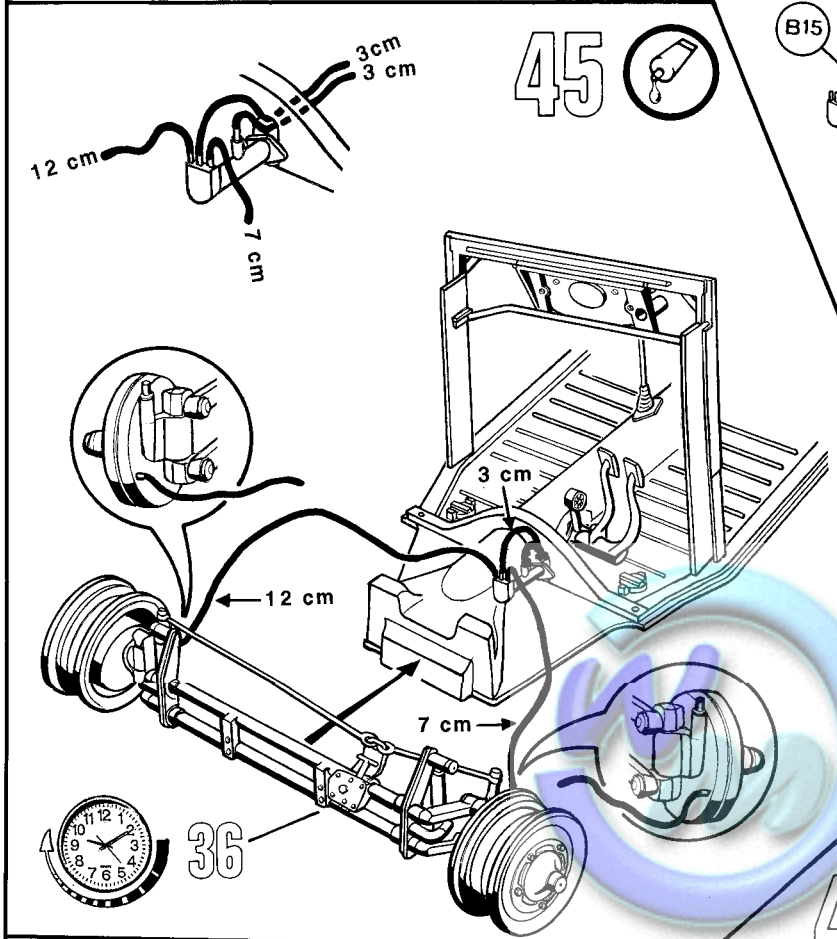
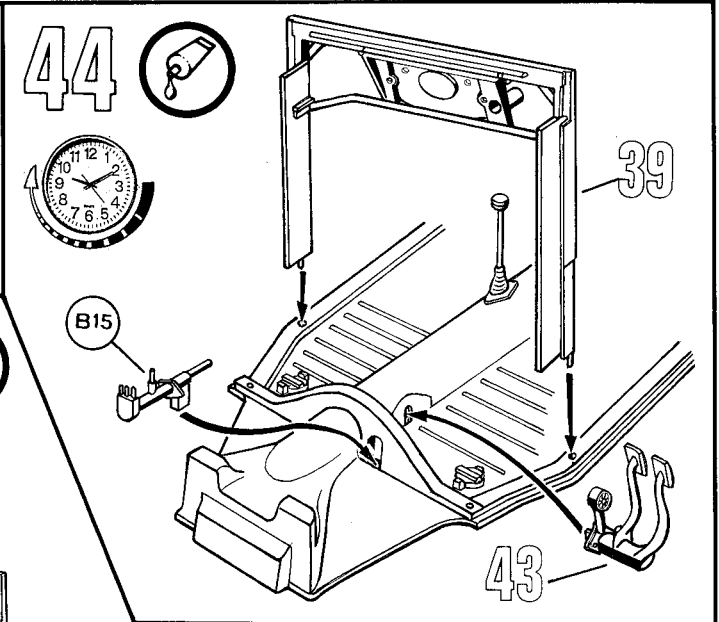
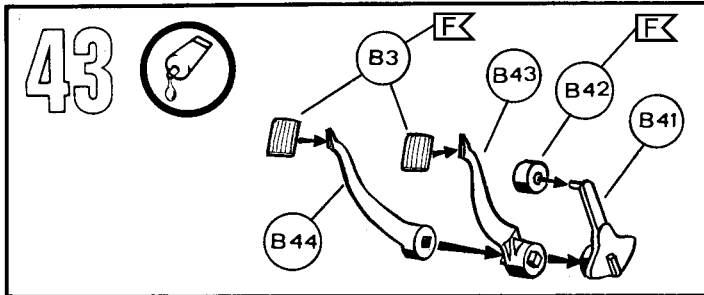

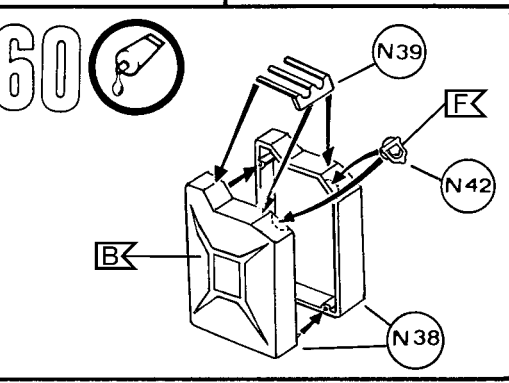
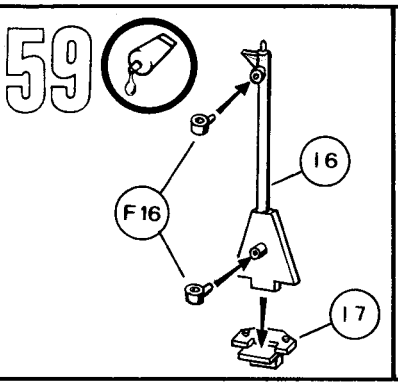
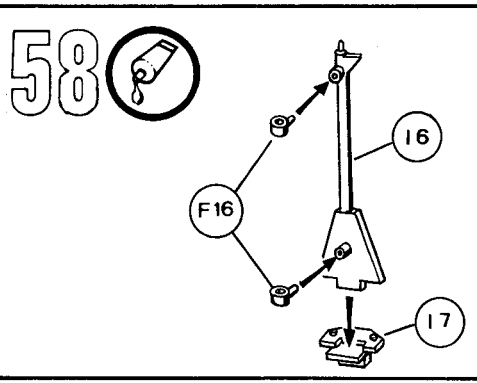
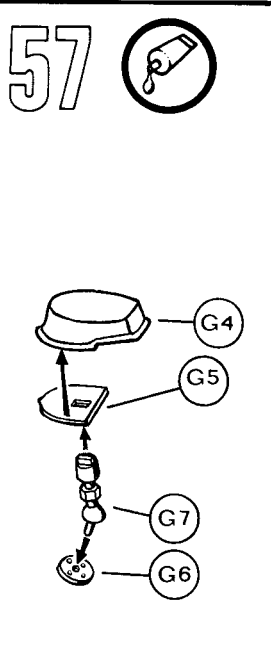
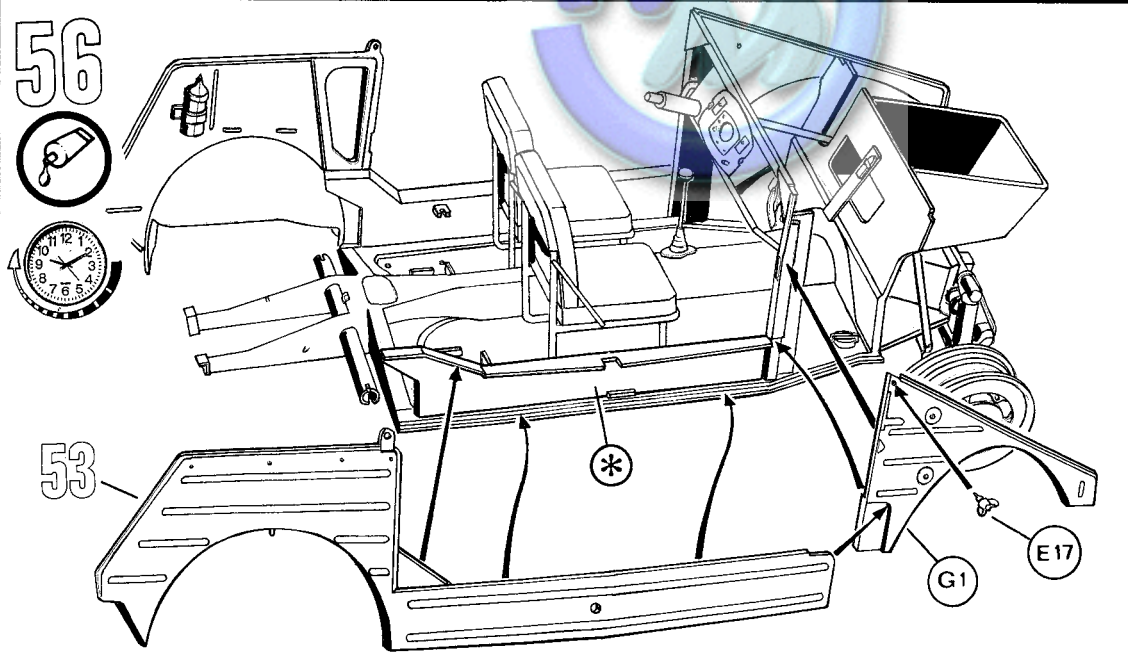
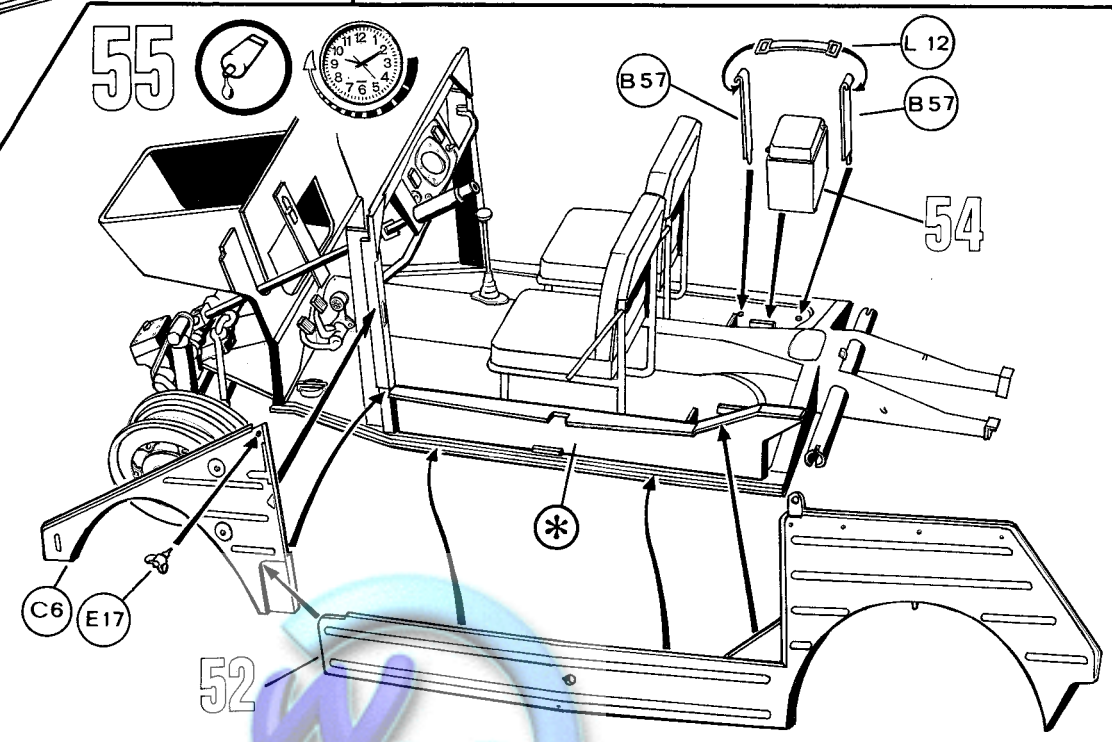
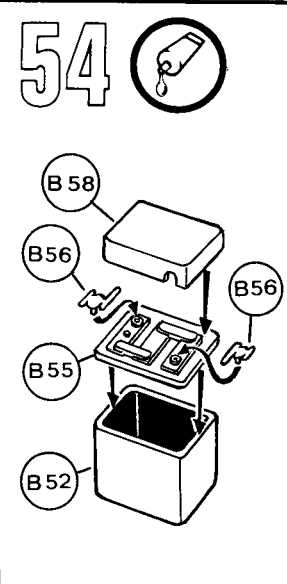
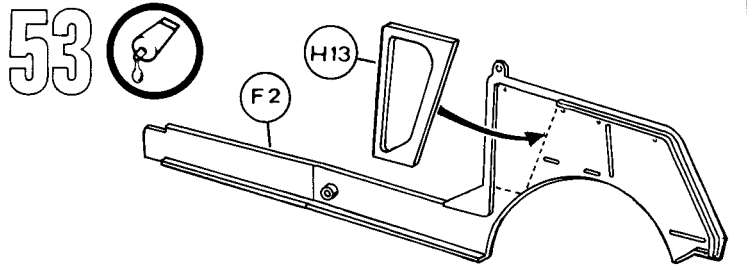
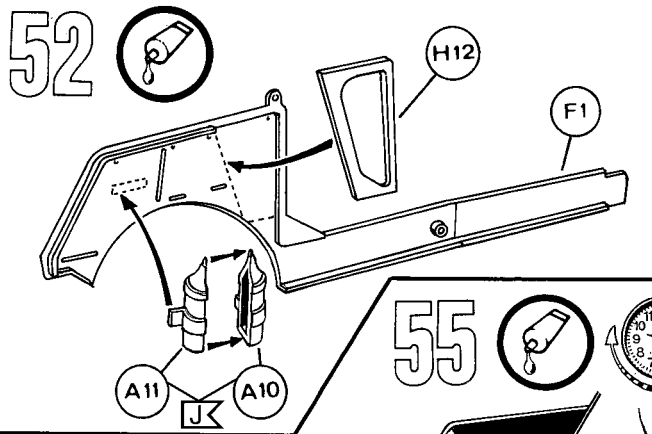

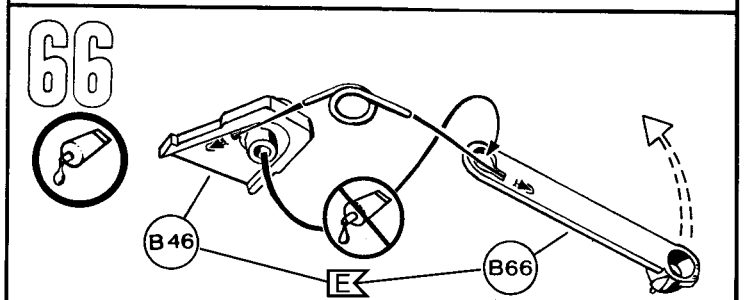
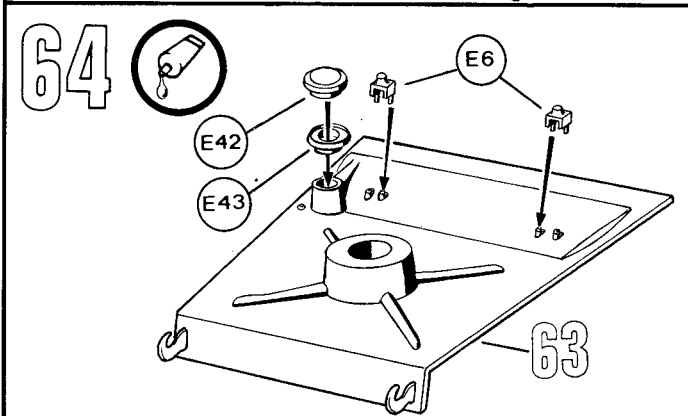
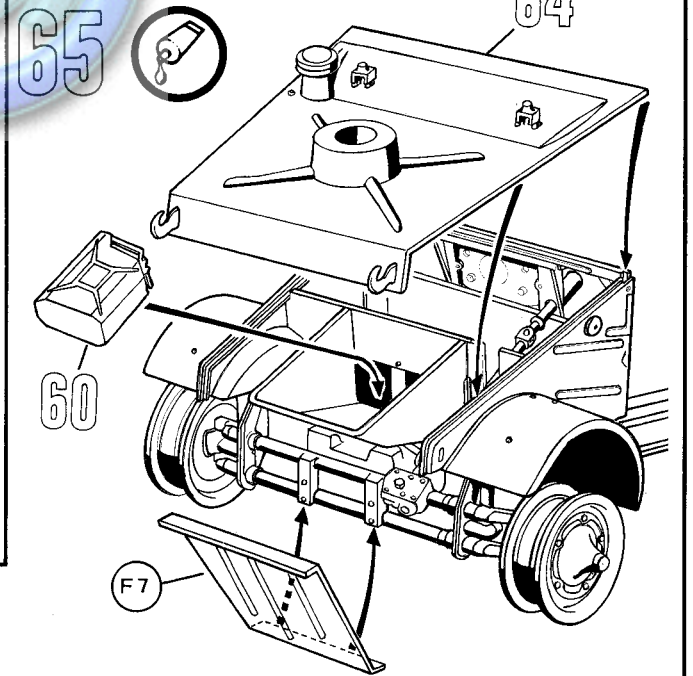
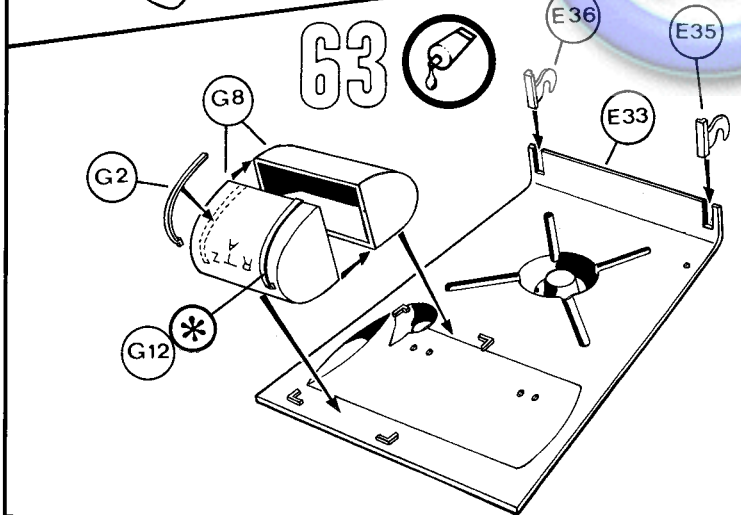
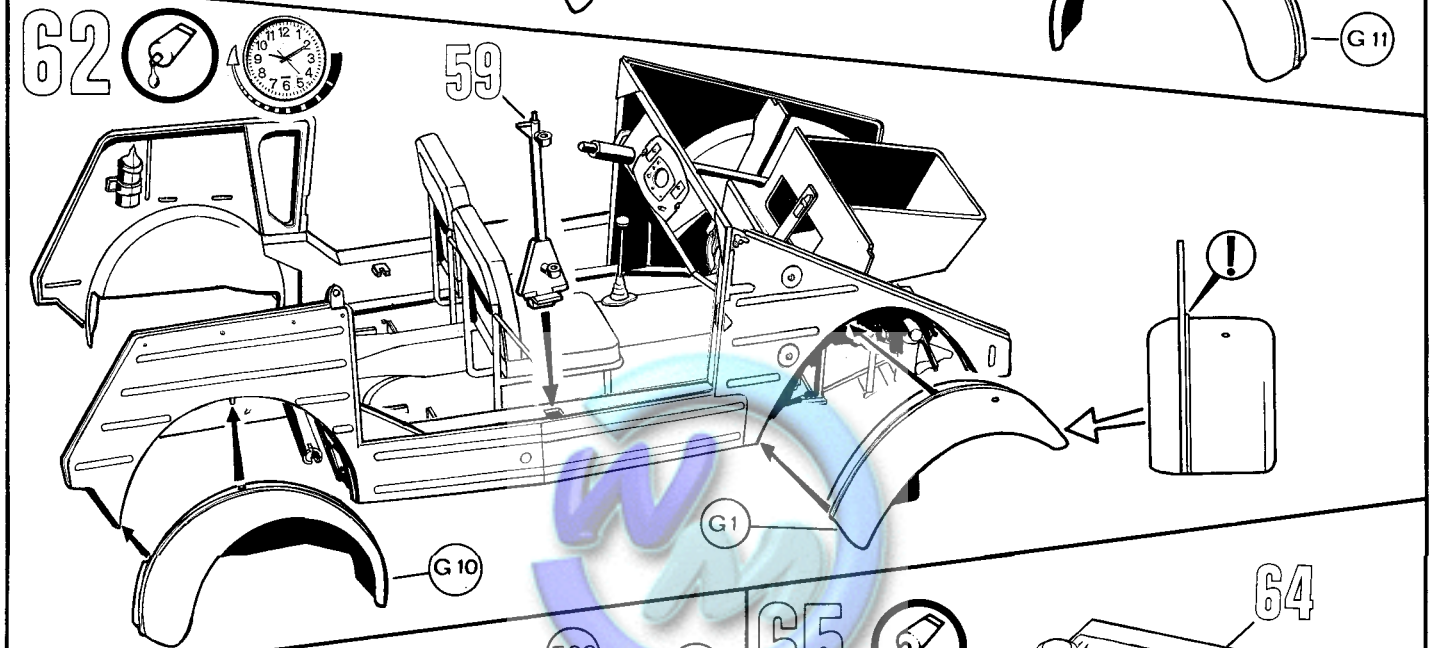
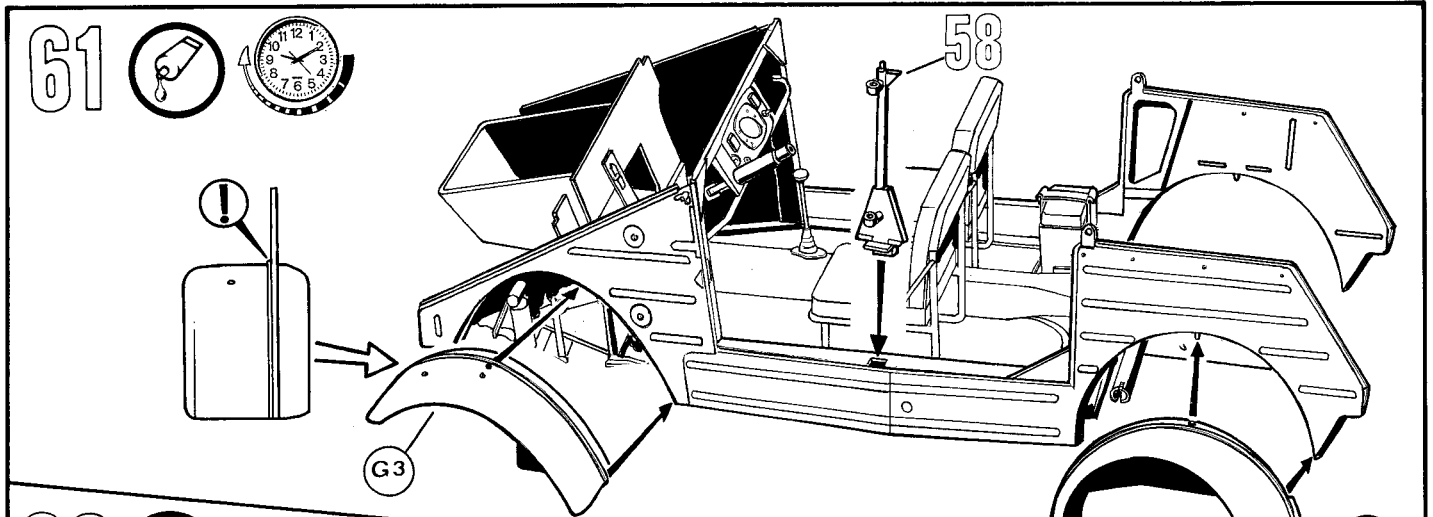

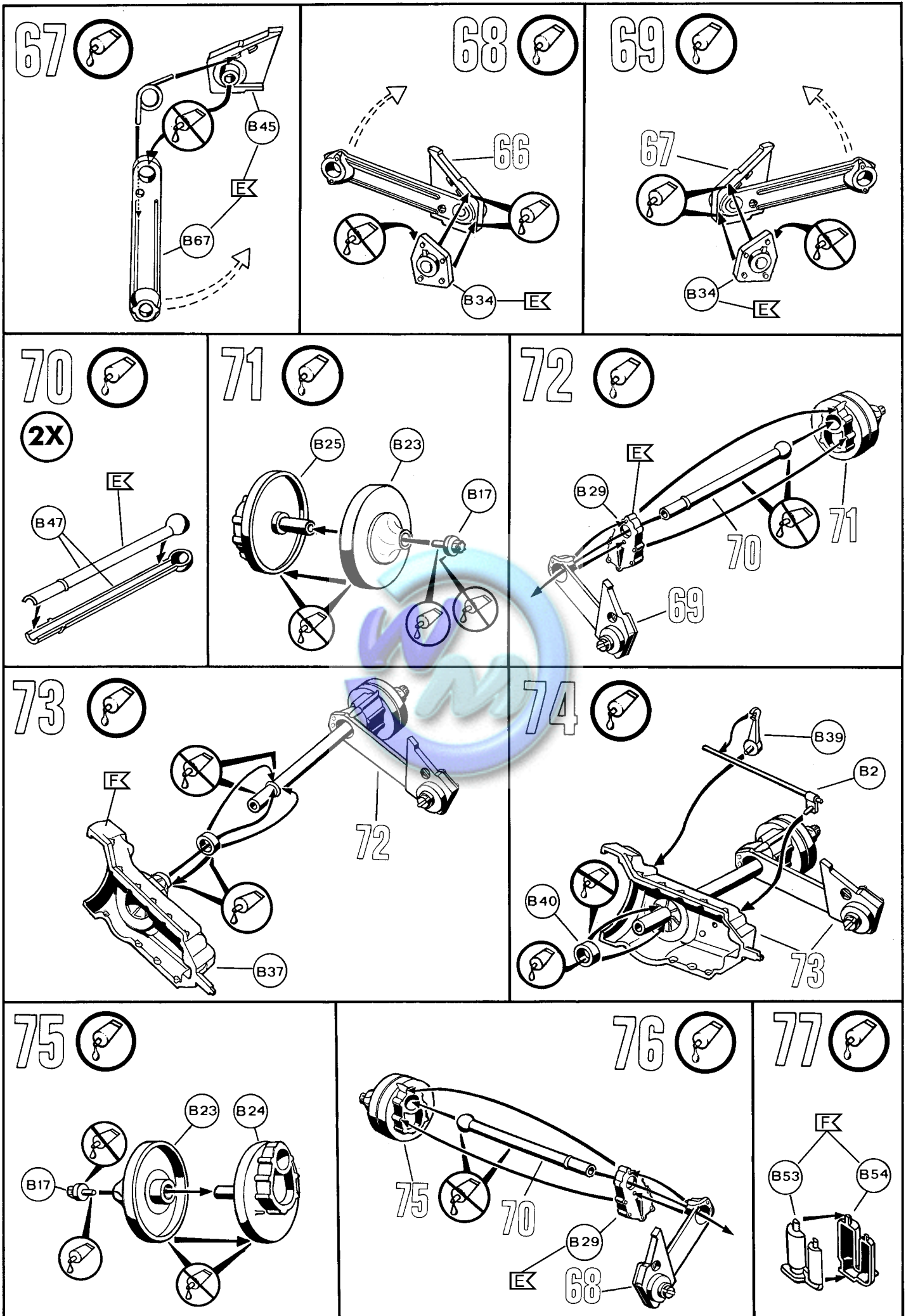

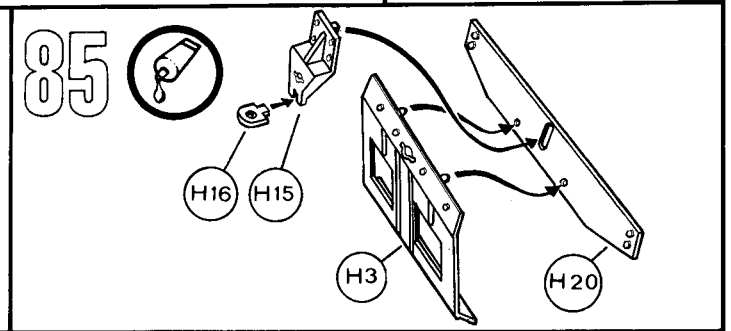
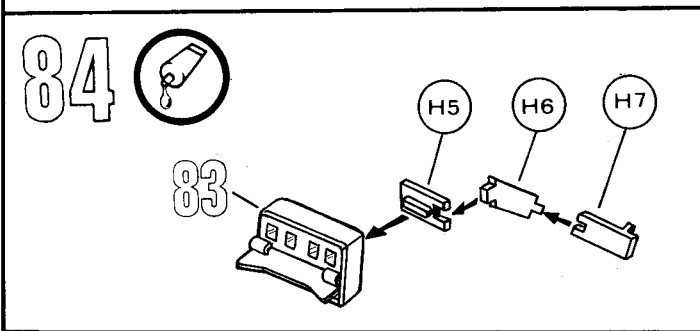
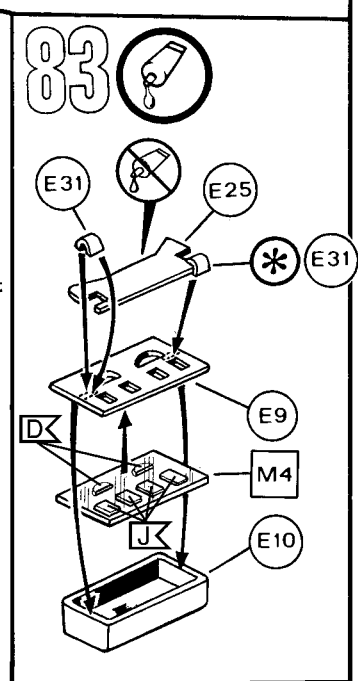
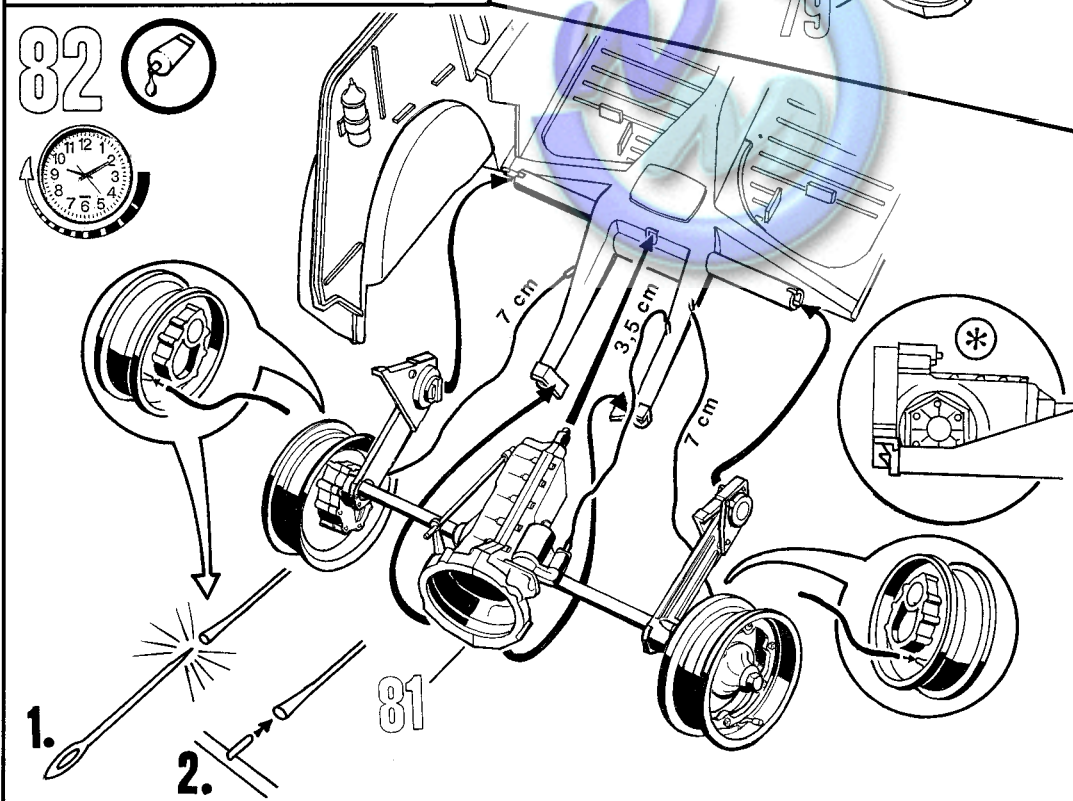
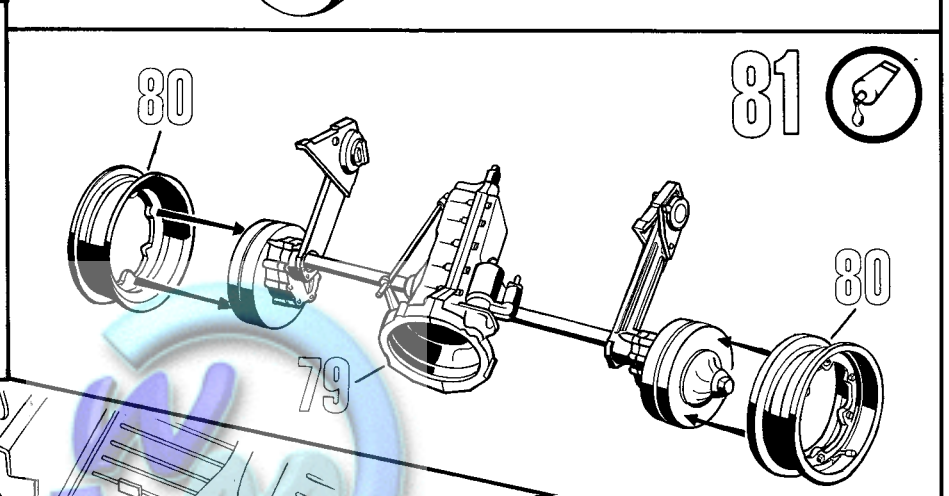
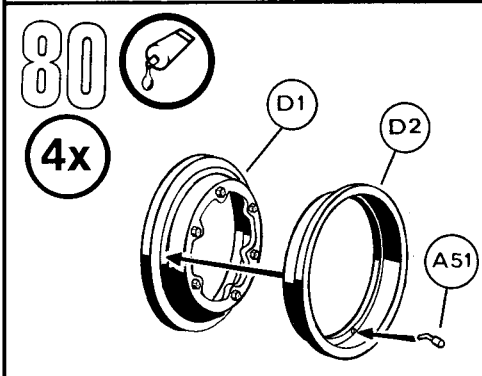
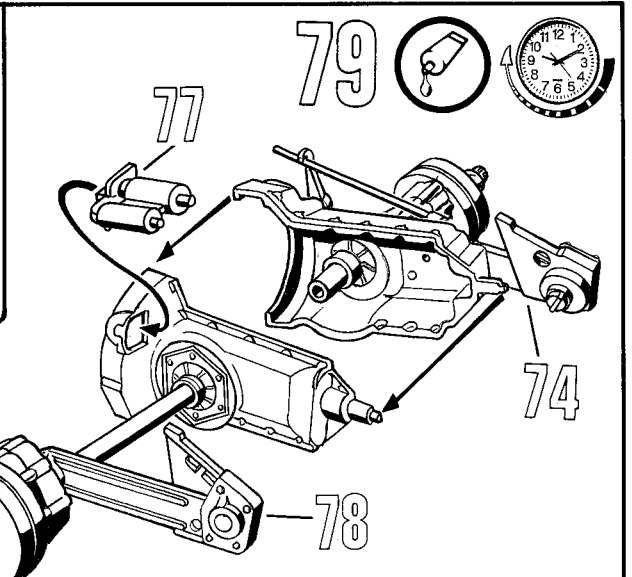
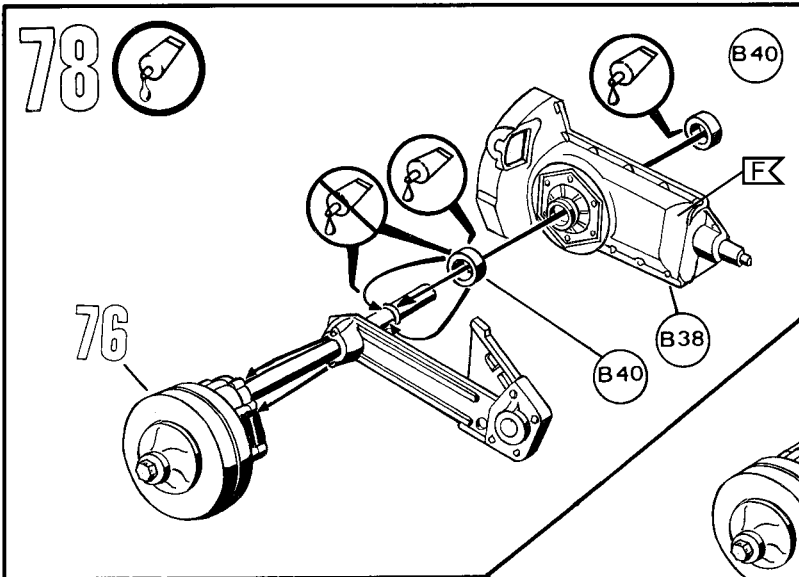

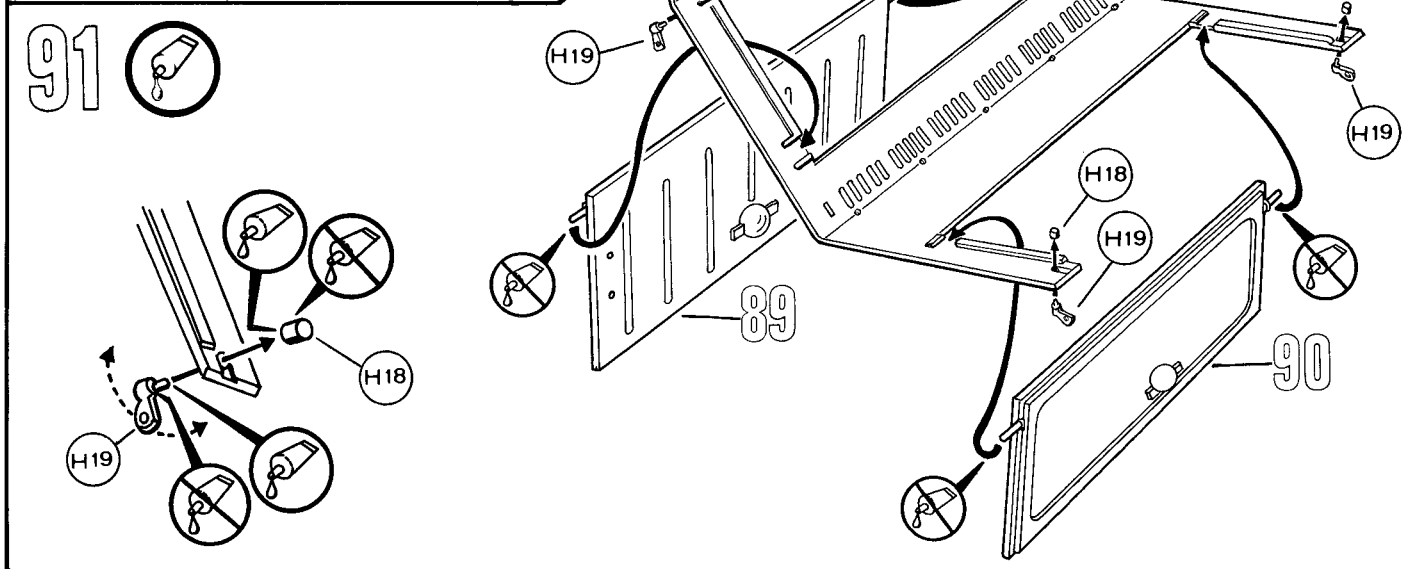
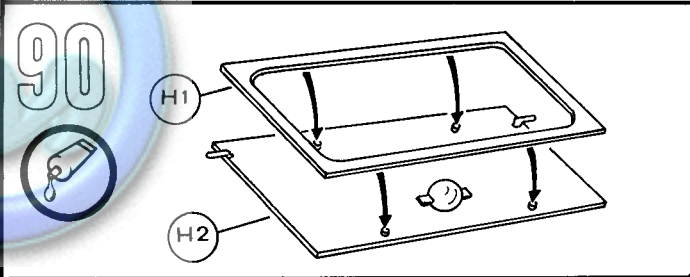
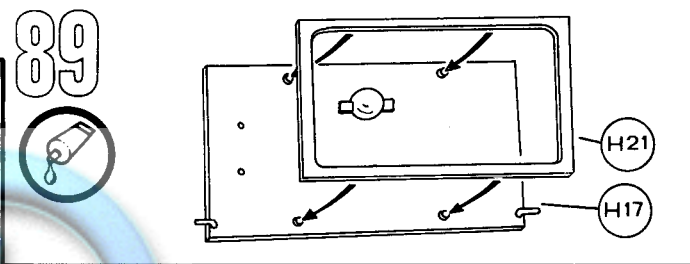
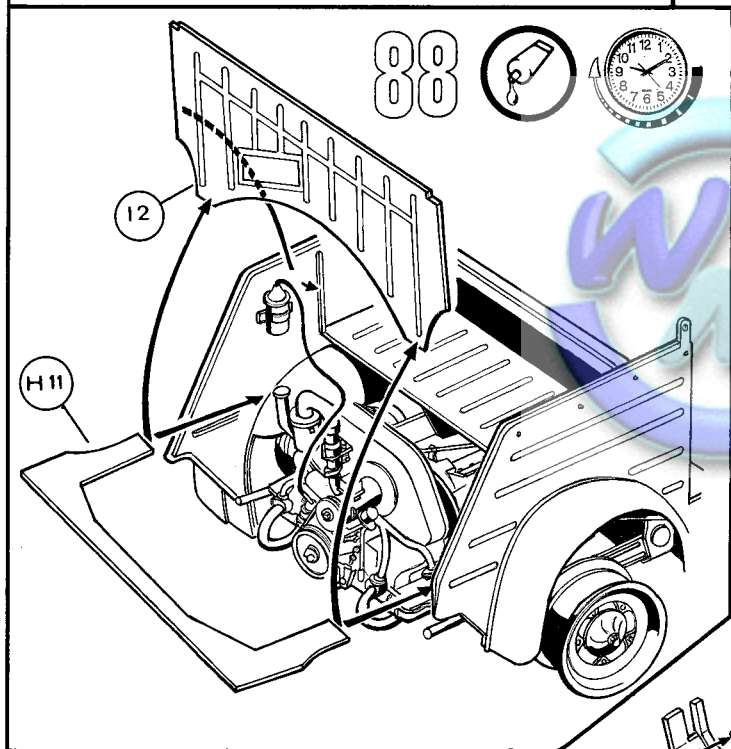
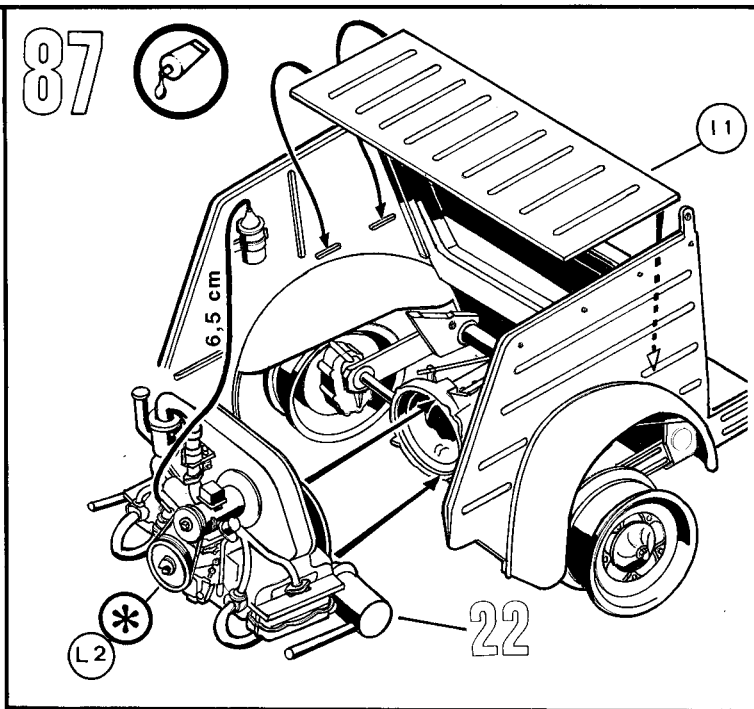
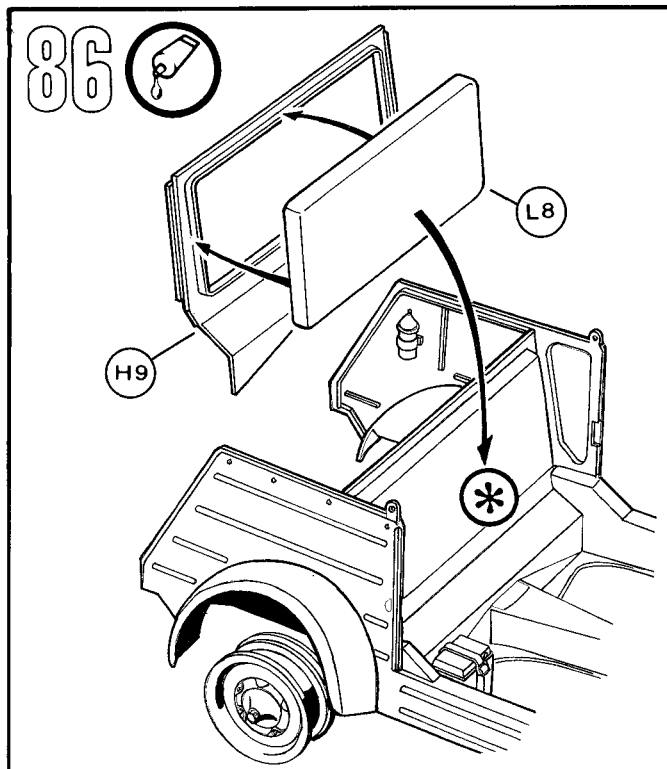

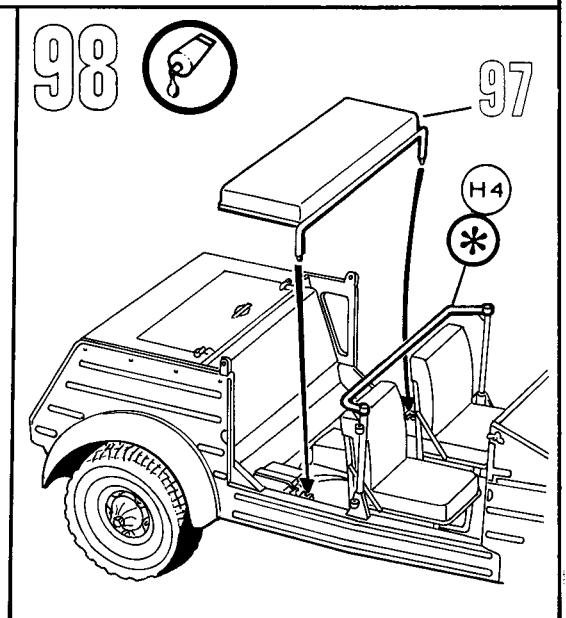
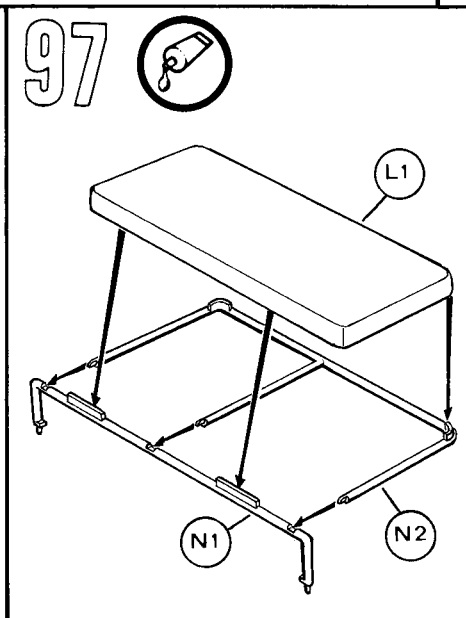
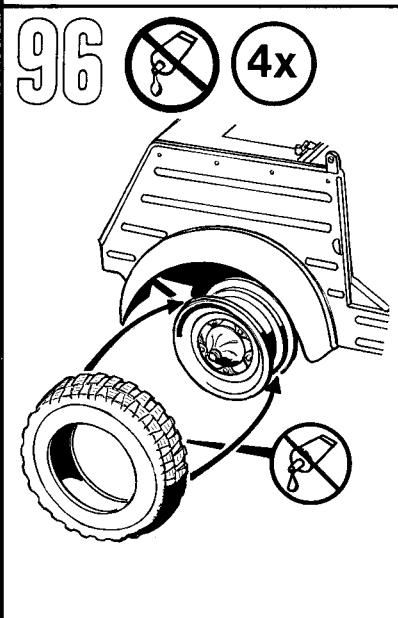
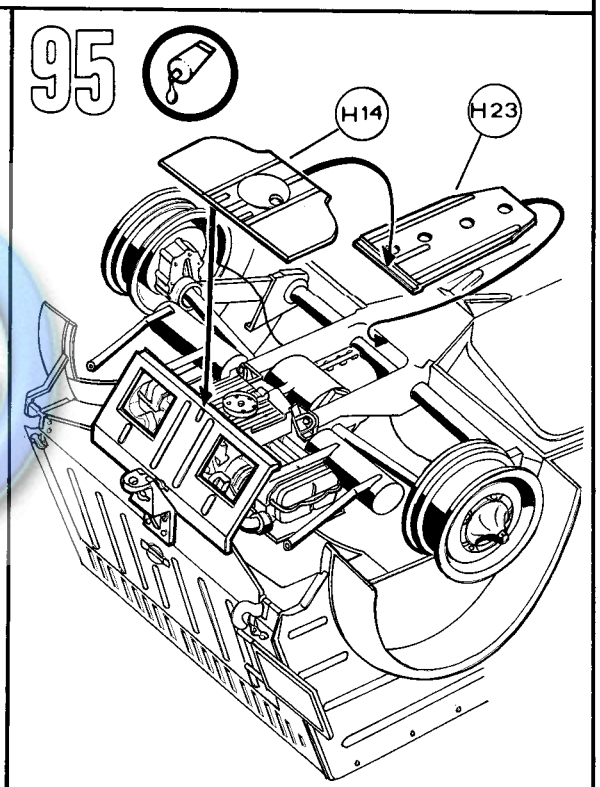
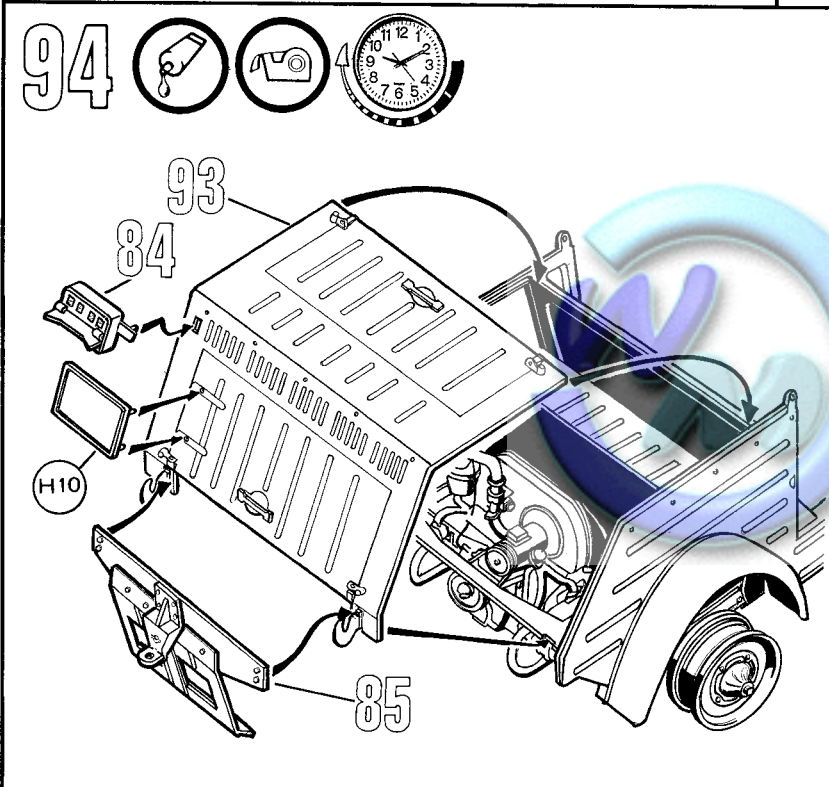
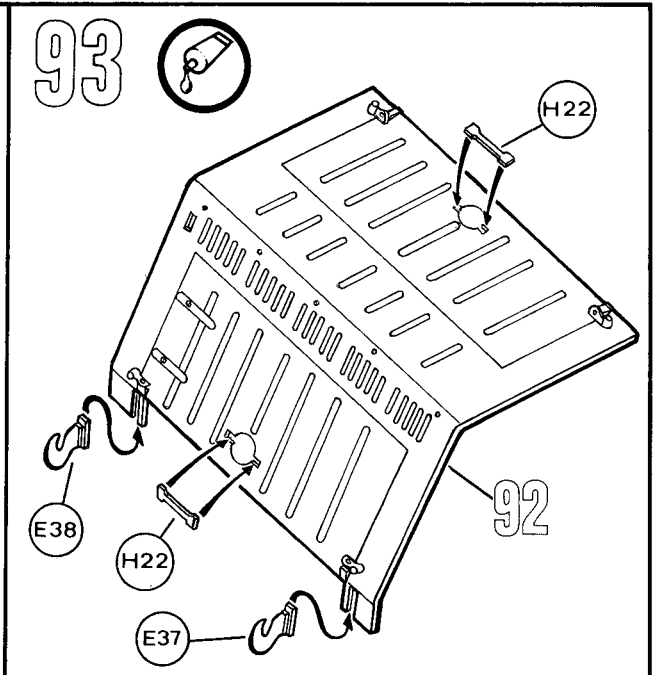
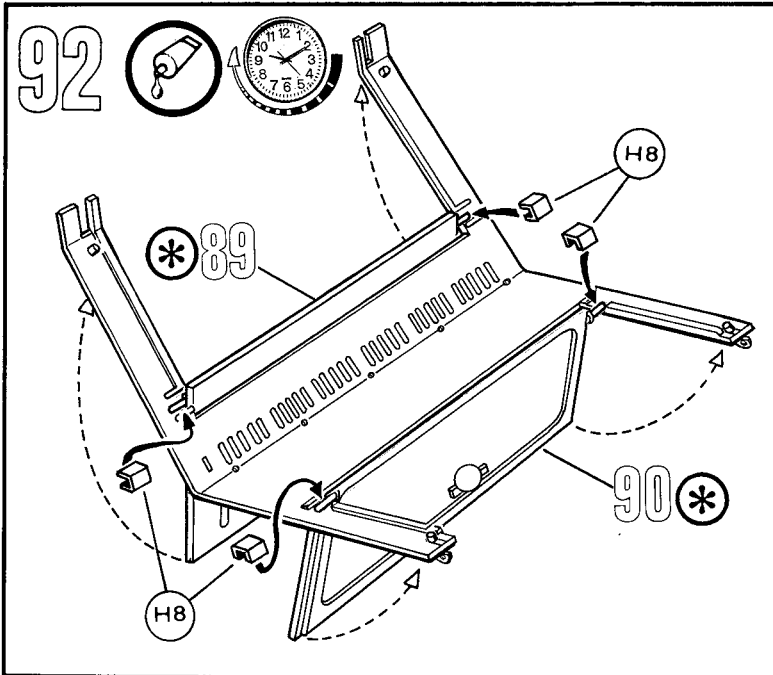

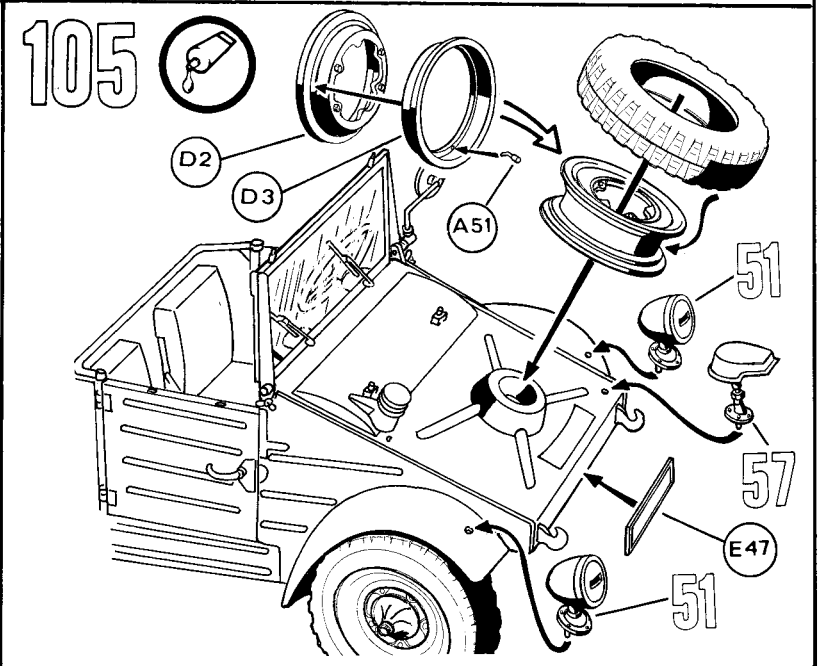
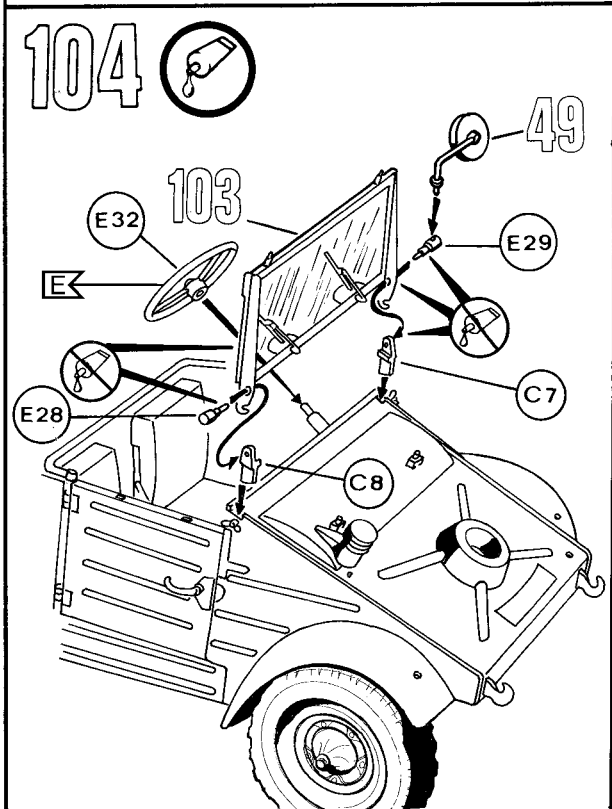
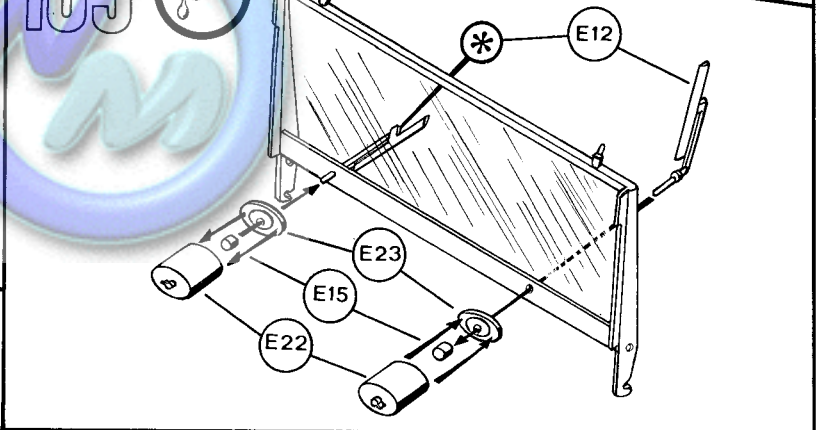
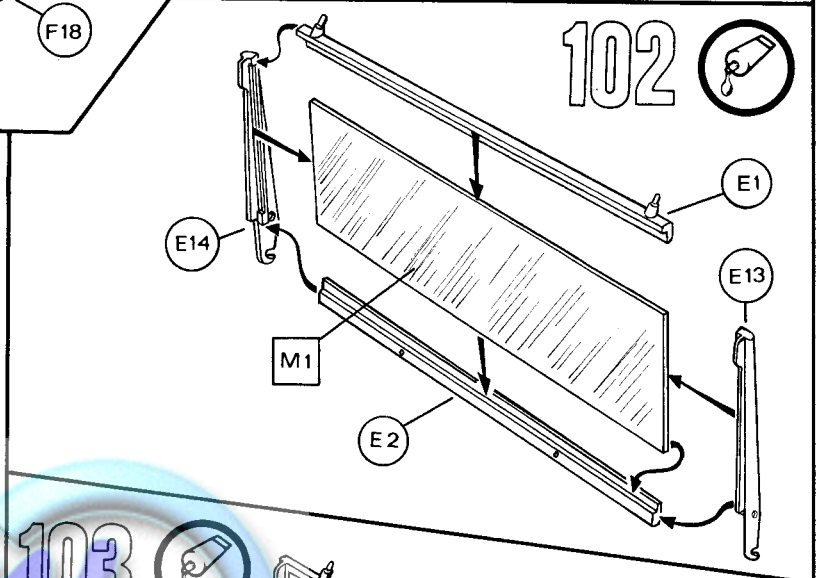
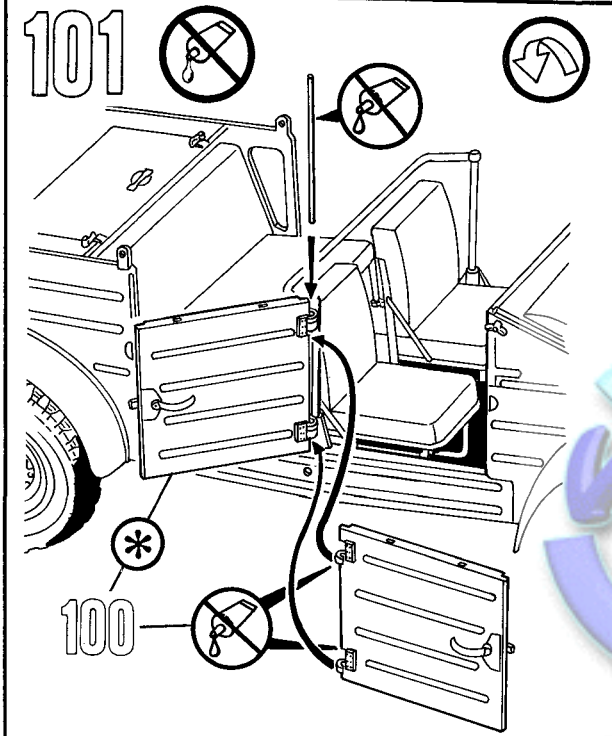
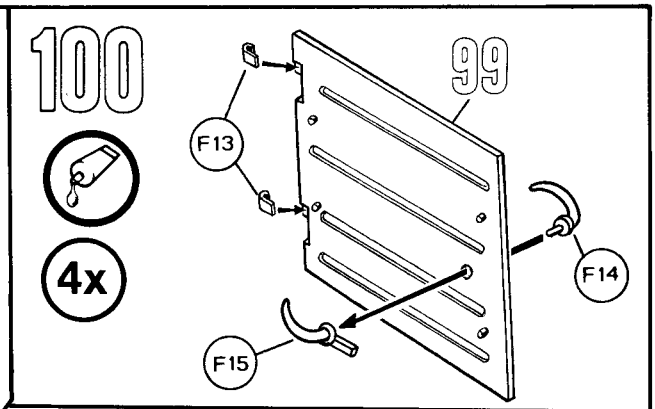
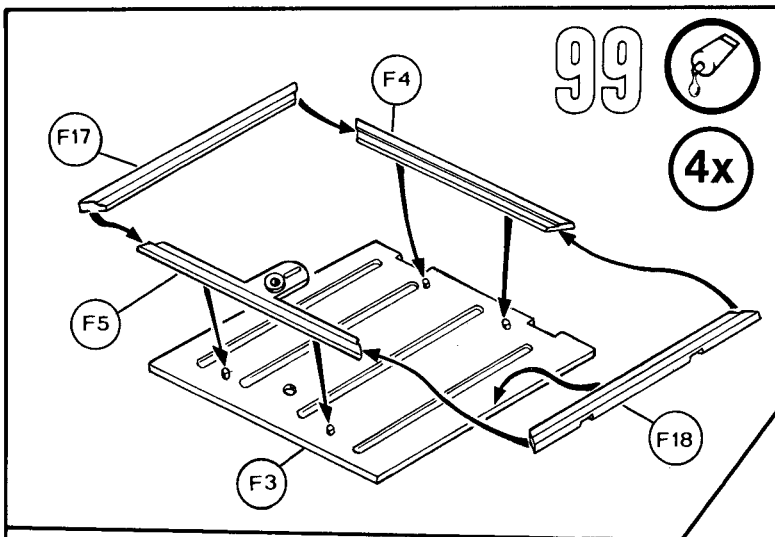

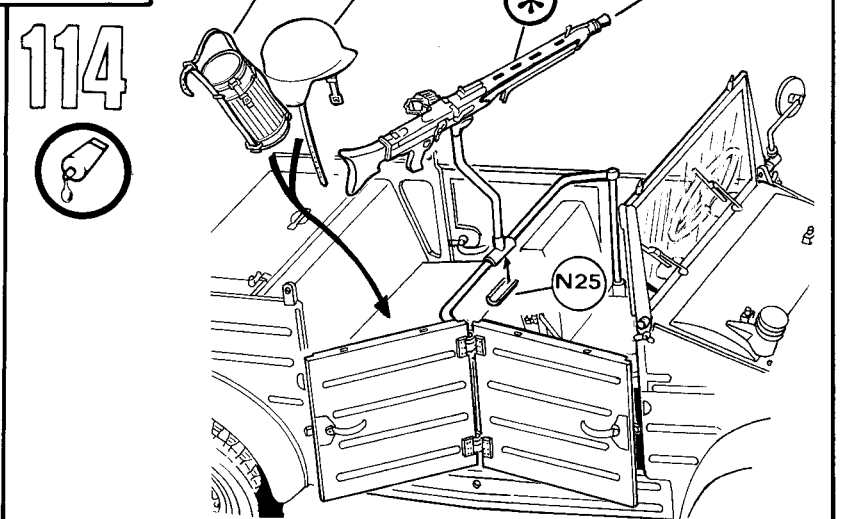
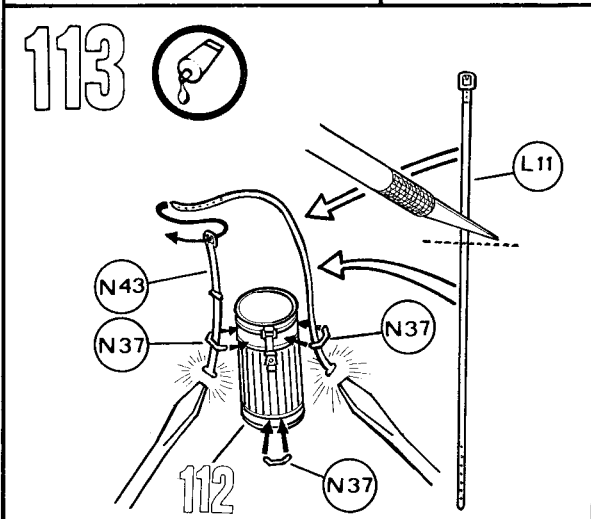
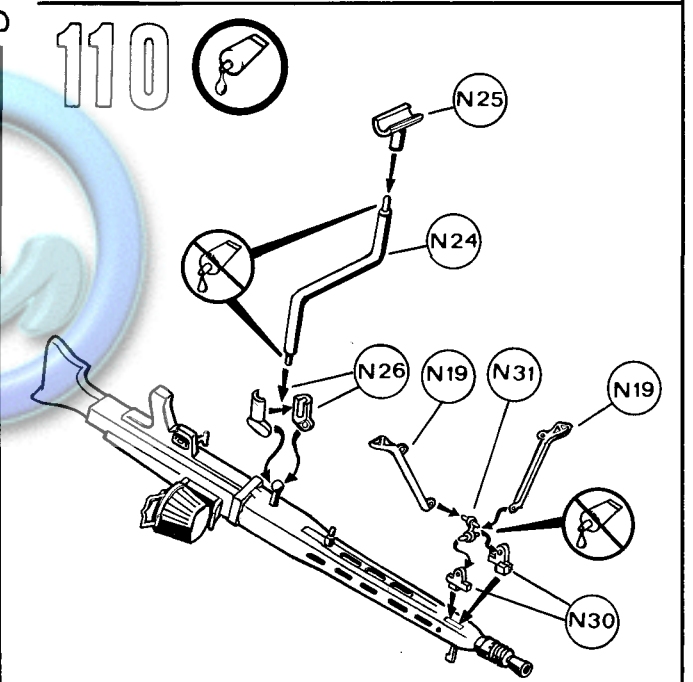
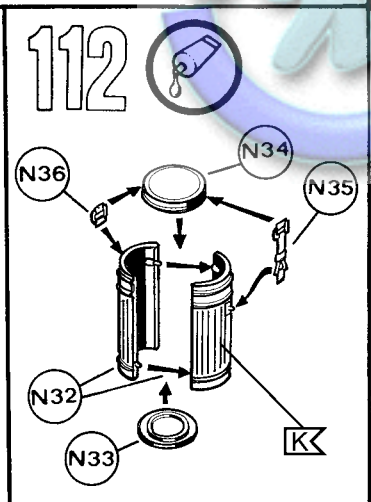
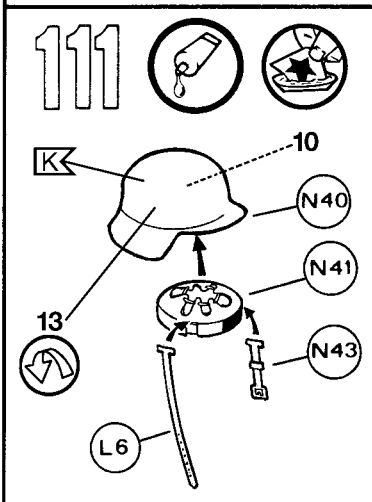
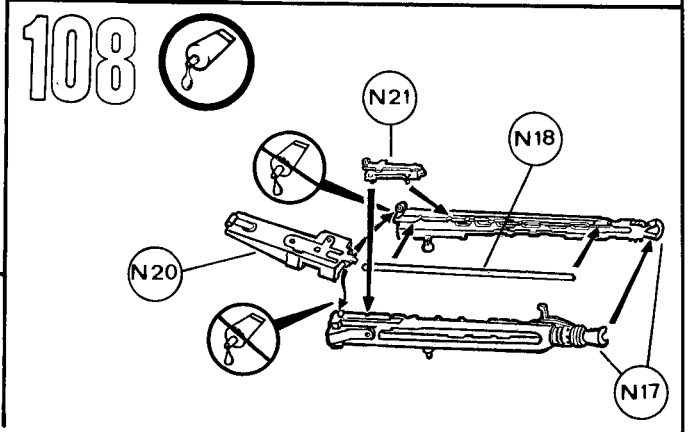
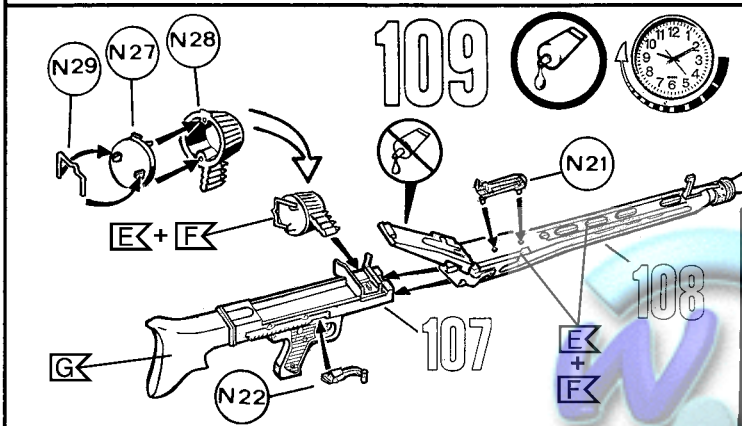
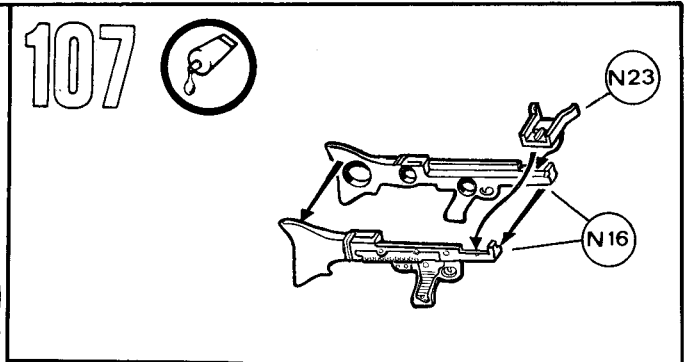
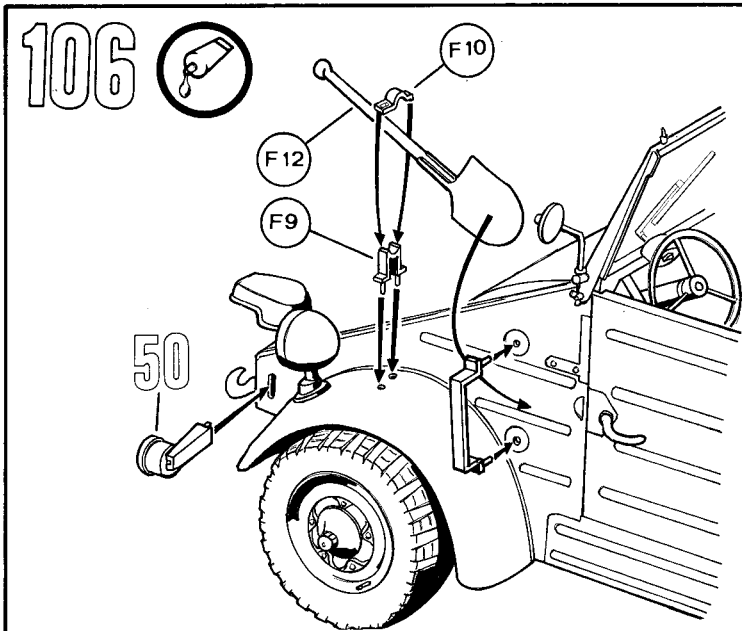

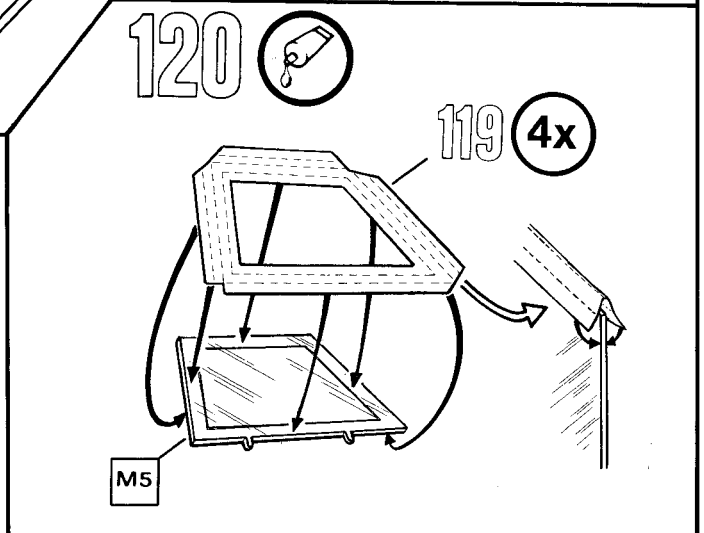
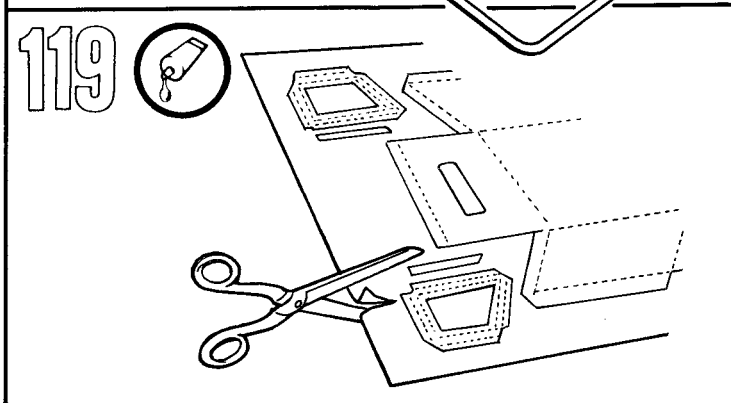
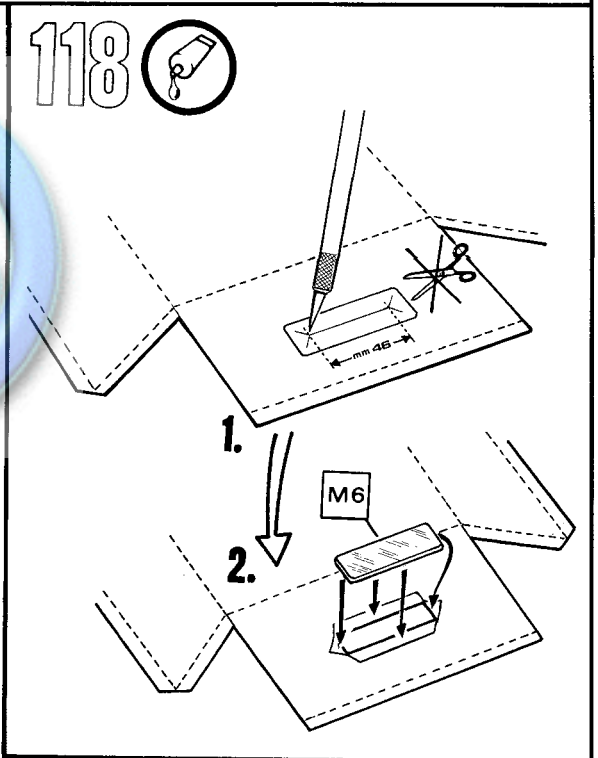
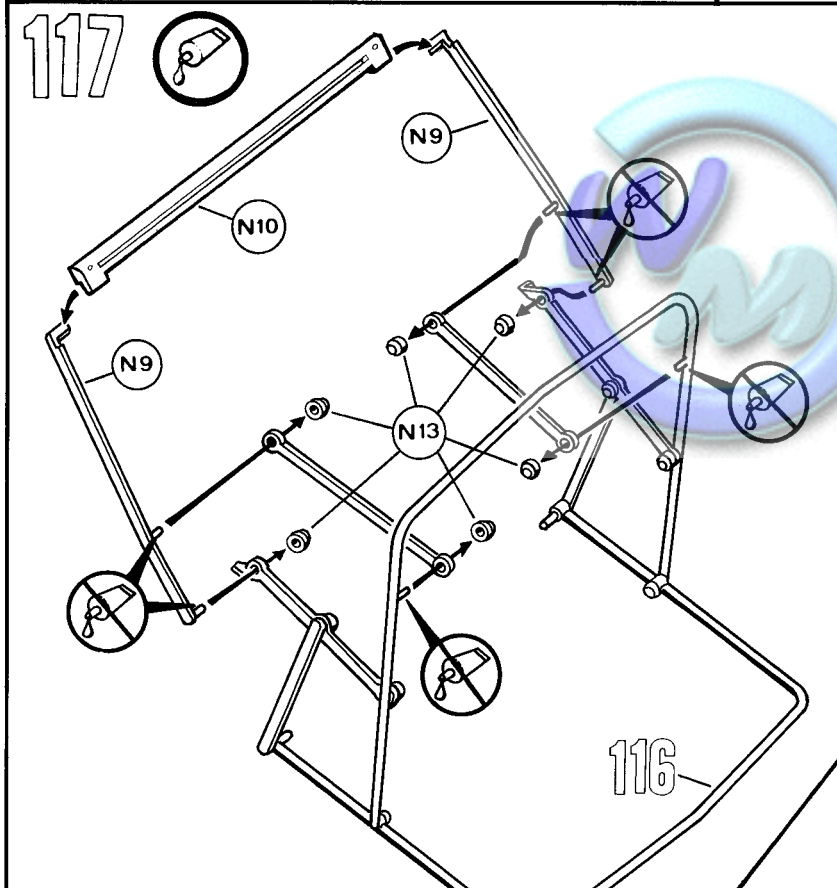
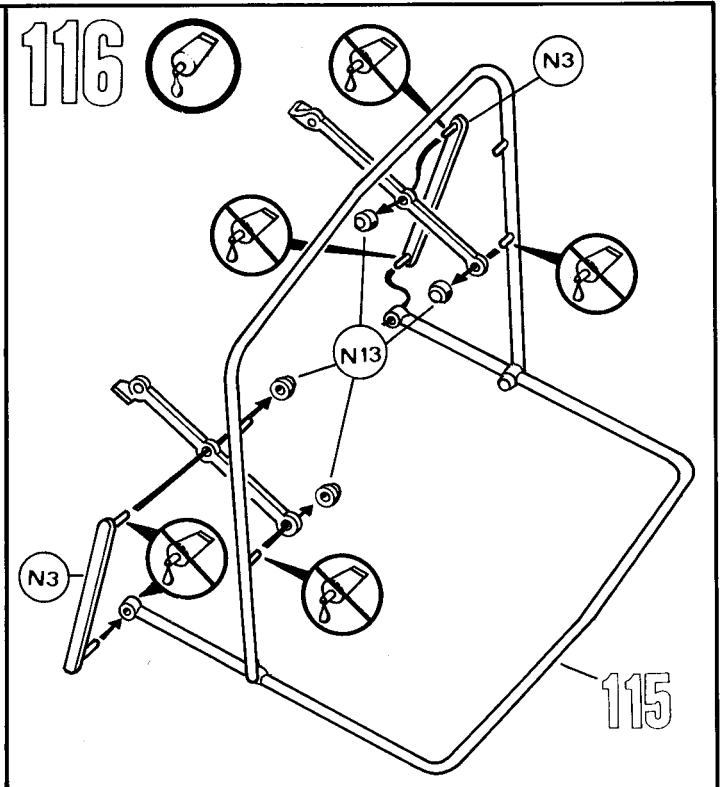
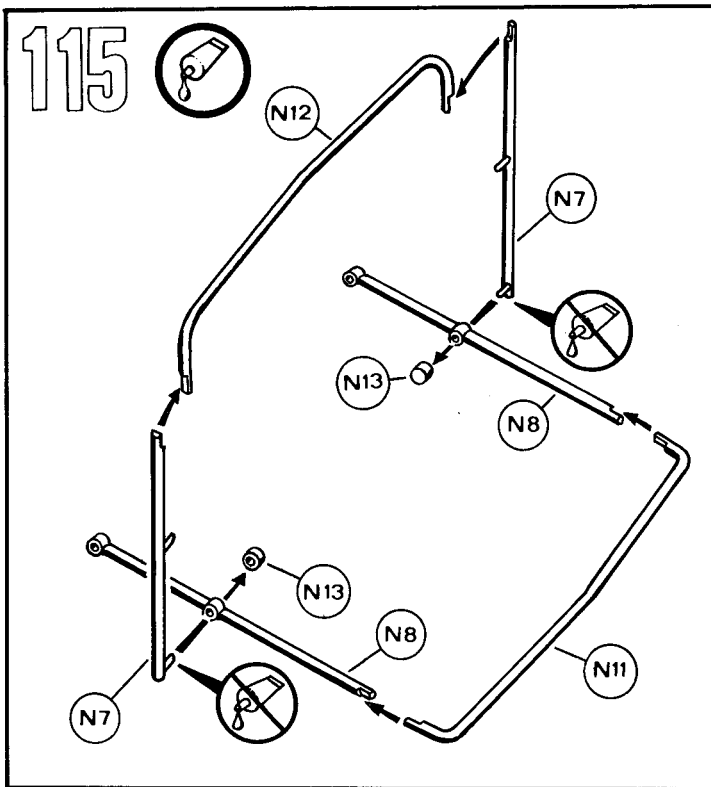

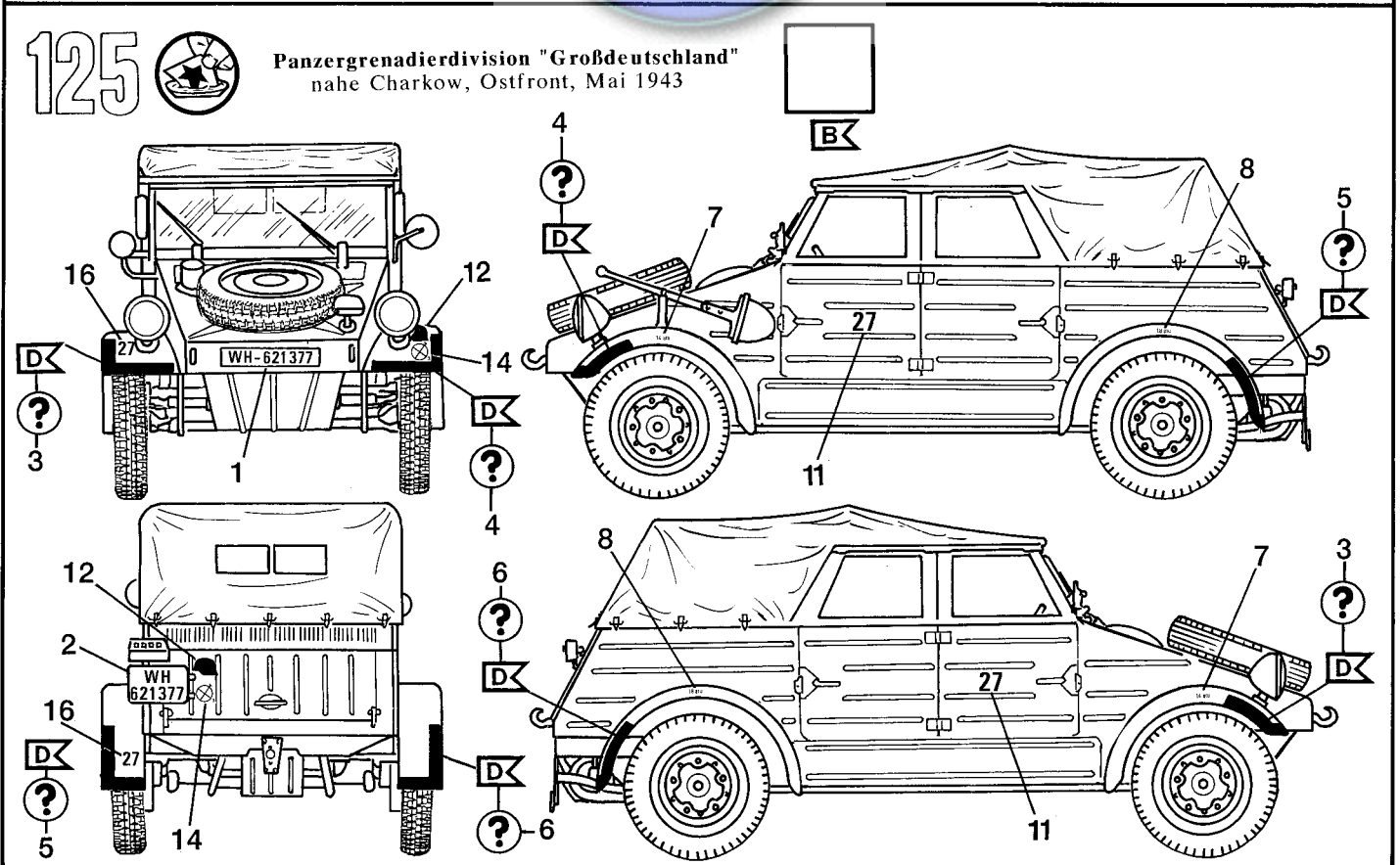
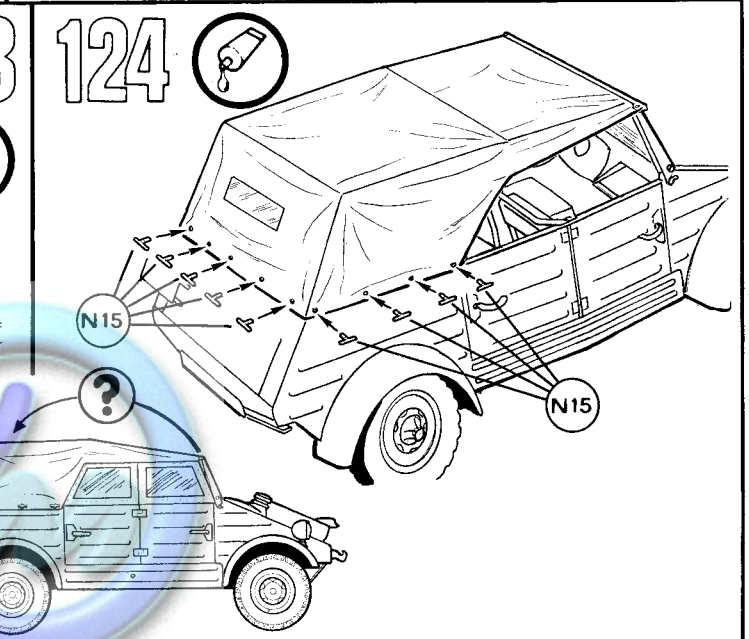
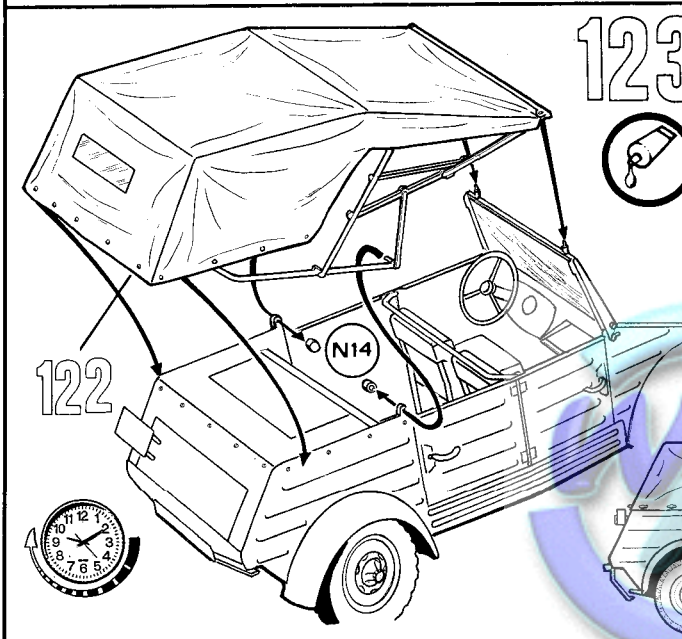
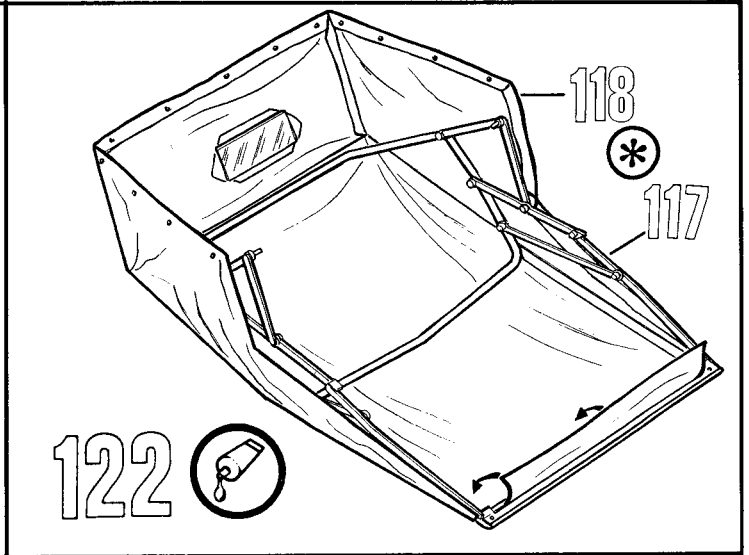
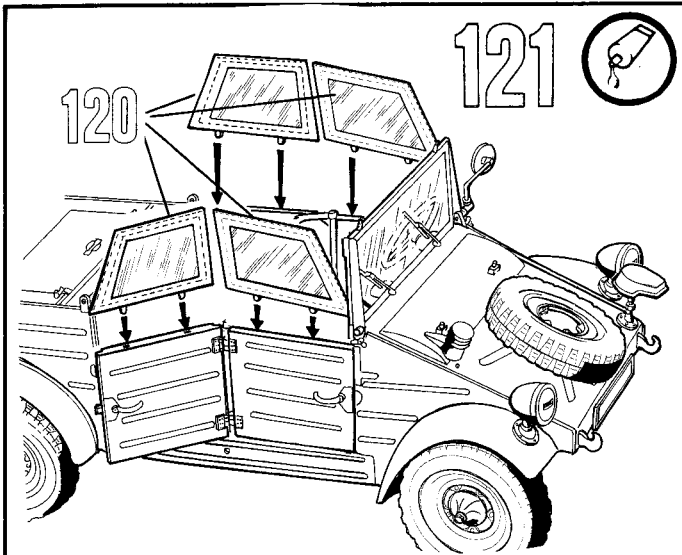

126



3. Pz Gren Div.
Einpoli, Italien, Juli 1944

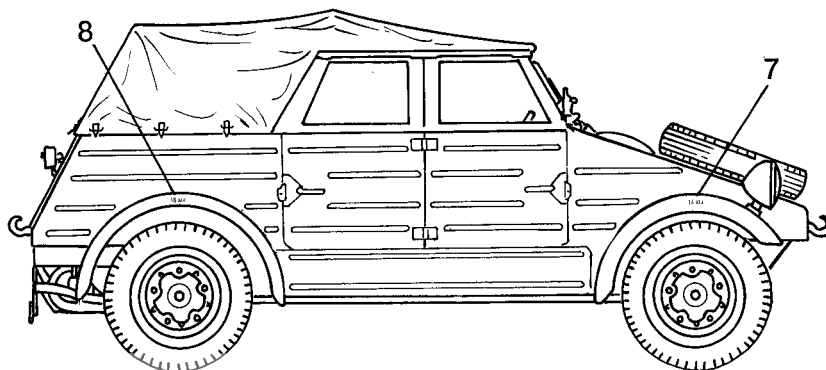
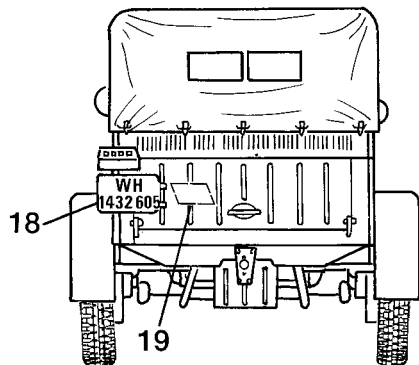
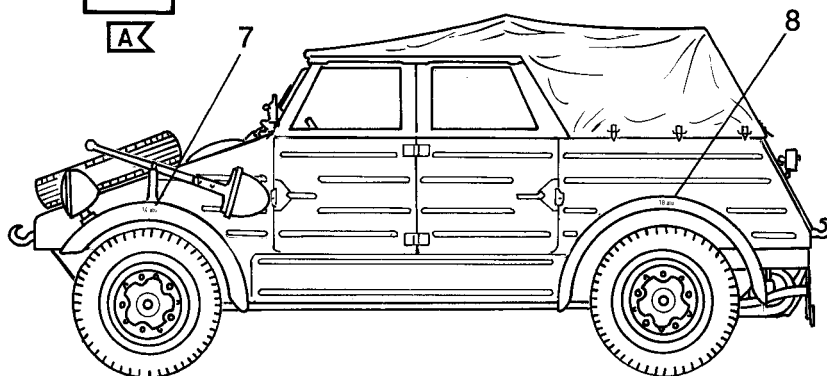
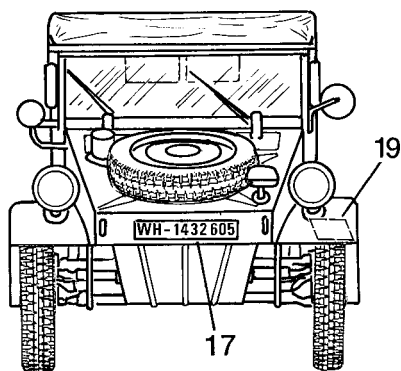

127



6. Panzerdivision
Wolokolamsk, Russland, Dezember 1941



B

D

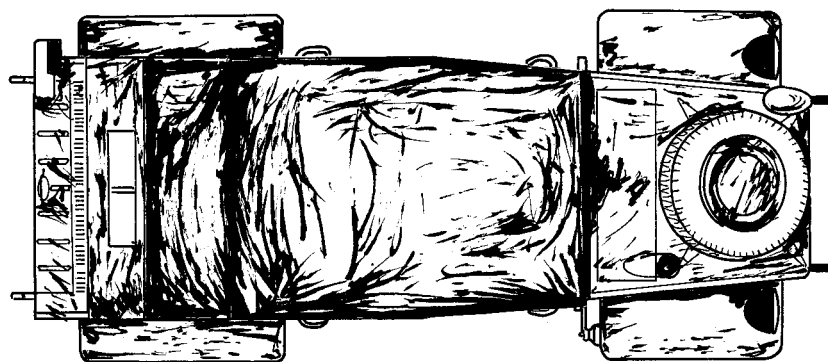
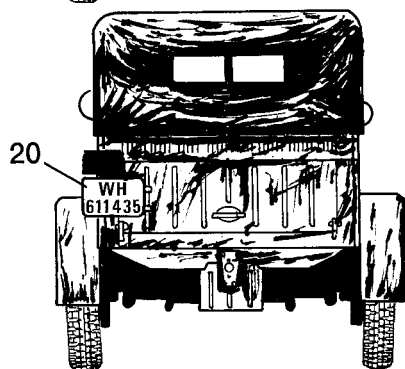
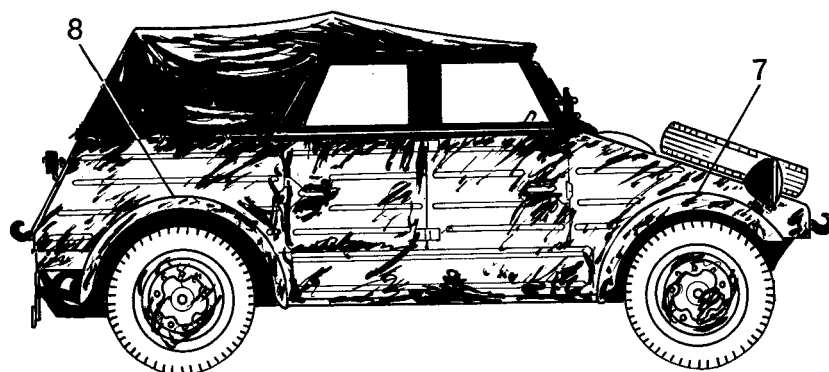
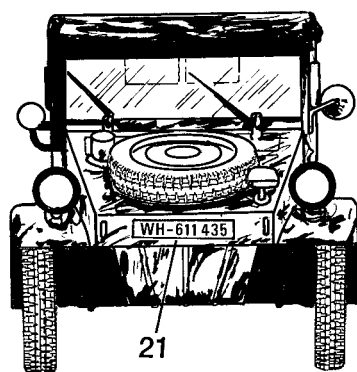
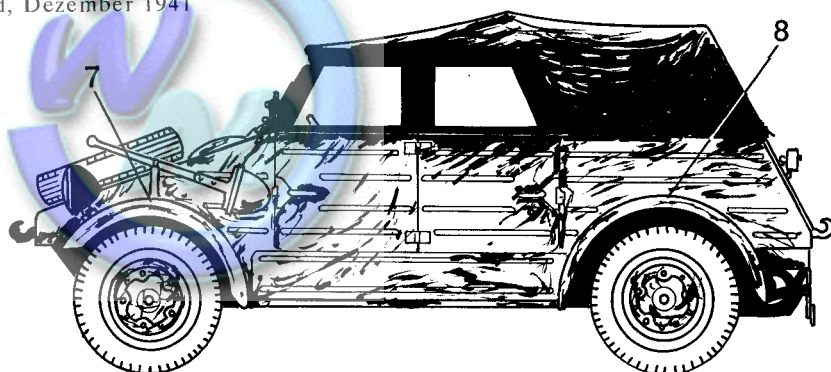

128



21. Panzerdivision
nahe Caen, Normandie, Juli 1944



A

C

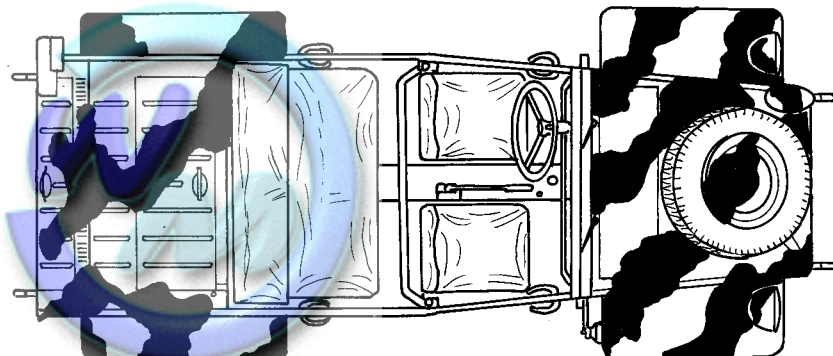
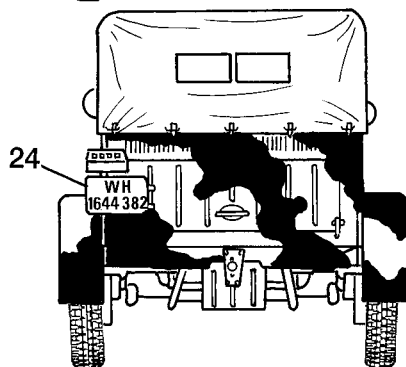
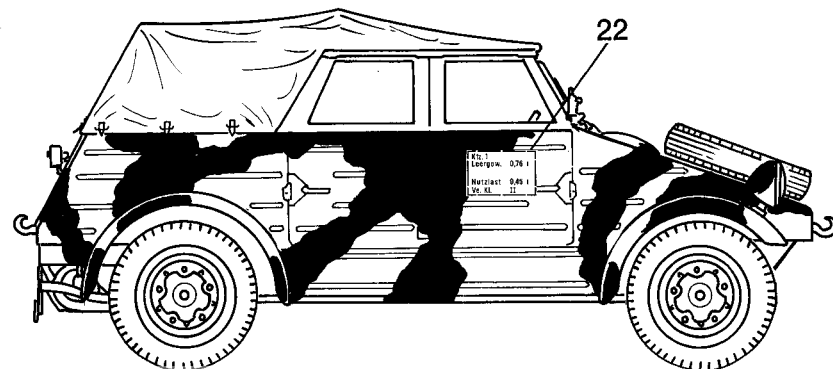
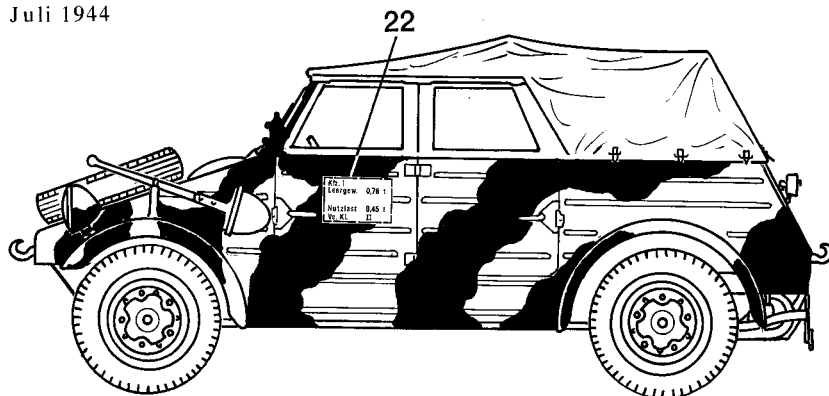
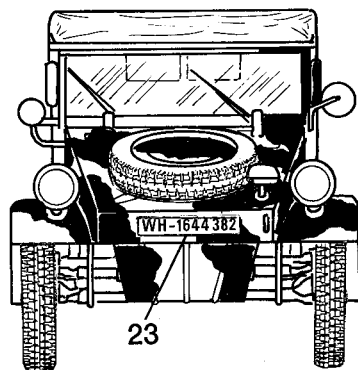

129



Sowjetische Armee (Beutefahrzeug)
Wilna, Juli 1944



A

